

CHEVROLET CORVETTE

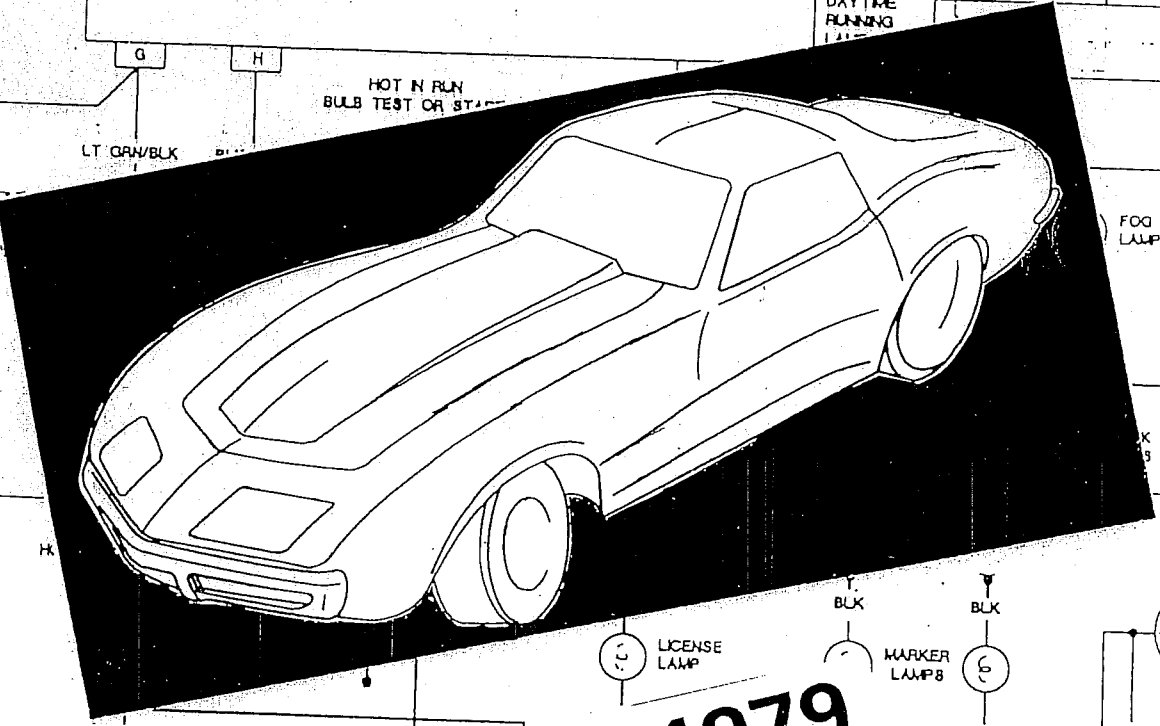

1976 - 1979

Elektrik - Schaltpläne

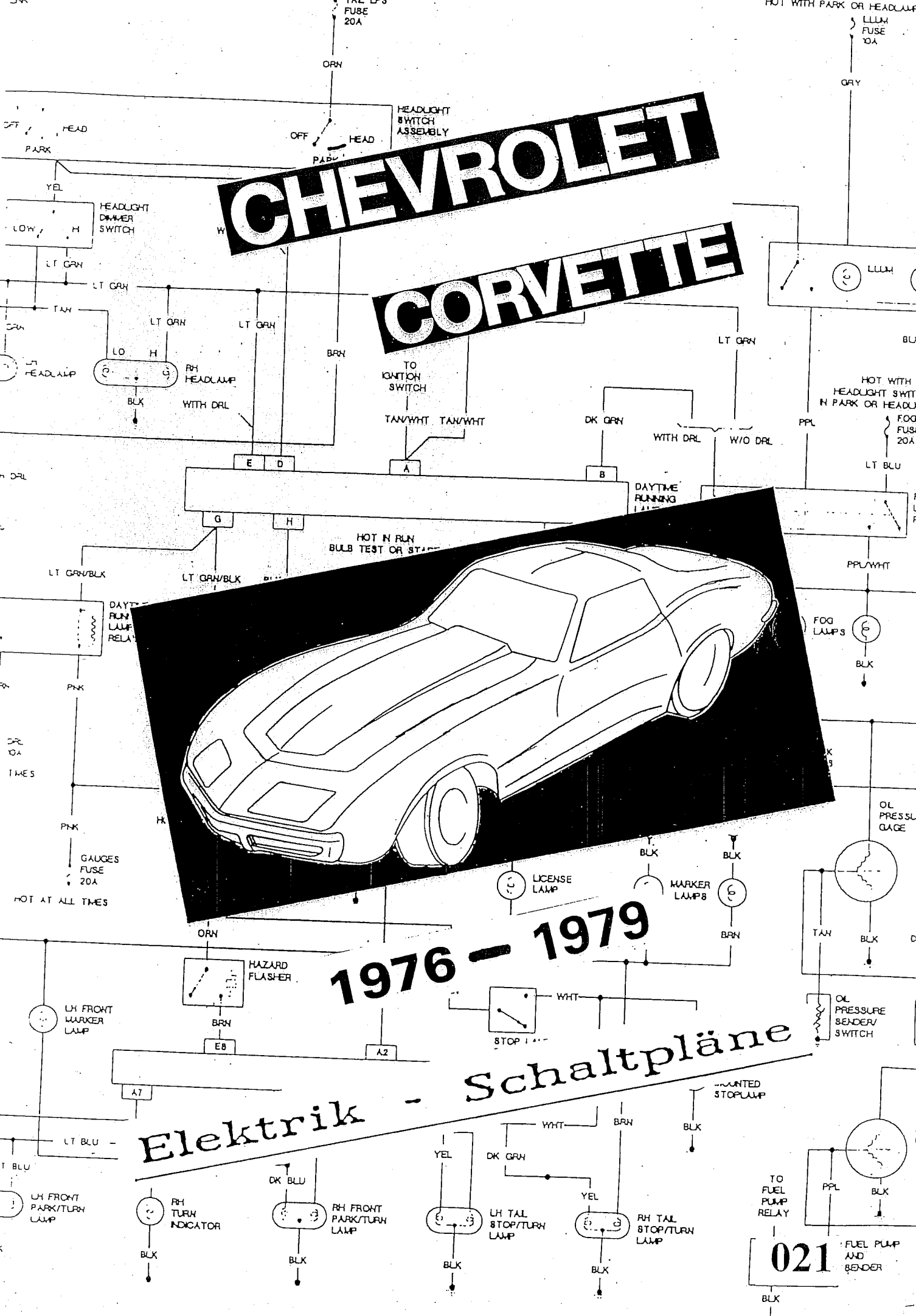

021

FUEL PUMP AND BENDER

CORVETTE

1976 - 1979

Kabelfarben:

G R Y = grau
 DK B L U = dunkelblau
 B L U = blau
 P N K = pink
 DK G R N = dunkelgrün
 B R N = braun
 R E D = rot

Y E L = gelb
 B L K = schwarz
 T A N = gelbbraun
 L T B L U = hellblau
 W H T = weiß
 O R N = orange

Elektrik - Schaltpläne

Symbols

Stromkreisunterbrechung

Glühbirne

Lautsprecher

Heizbare Heckschleibe

Benzinanzeiger

Kabel-Nr.

Heize

Hupe

Elektro-Motor

Lichtschalter

Doppelpolschalter

Kabelfarben

• SPLICE
Verbindungspunkt

CIRCUIT BREAKER

RADIO SPEAKER

LIGHT BULB (DASH OUTLINE INDICATES REMAINDER OF BULB IS SHOWN ELSEWHERE)

Kabelverbinder
CONNECTOR

ANZÜNDER
CIGAR LIGHTER

REAR WINDOW HEATER

RELAY

BATTERY

REFERENCE FINDERS **A**
Such-Nr.

FUSE

FUEL GAUGE SENDER

Kondensator
CAPACITOR

ELECTRIC CHOKE HEATER

GROUND

HIGH PITCH HORN

REVERSIBLE MOTOR

DUAL FILAMENT LIGHT BULB *Doppelfadenbirne*

CIRCUIT NUMBER **351**

2 SPEED MOTOR *Elektro-Motor*

SWITCH AND LIGHT *Lichtschalter*

20 DK BLU/YEL
20 GAUGE WIRE
DARK BLUE
OVERALL COLOR
WITH A YELLOW
STRIPE

DOUBLE POLE SWITCH *Doppelpolschalter*

TURN SIGNAL FLASHER *Drehschalter*

Musterverdrahtung

WIRING DIAGRAMS

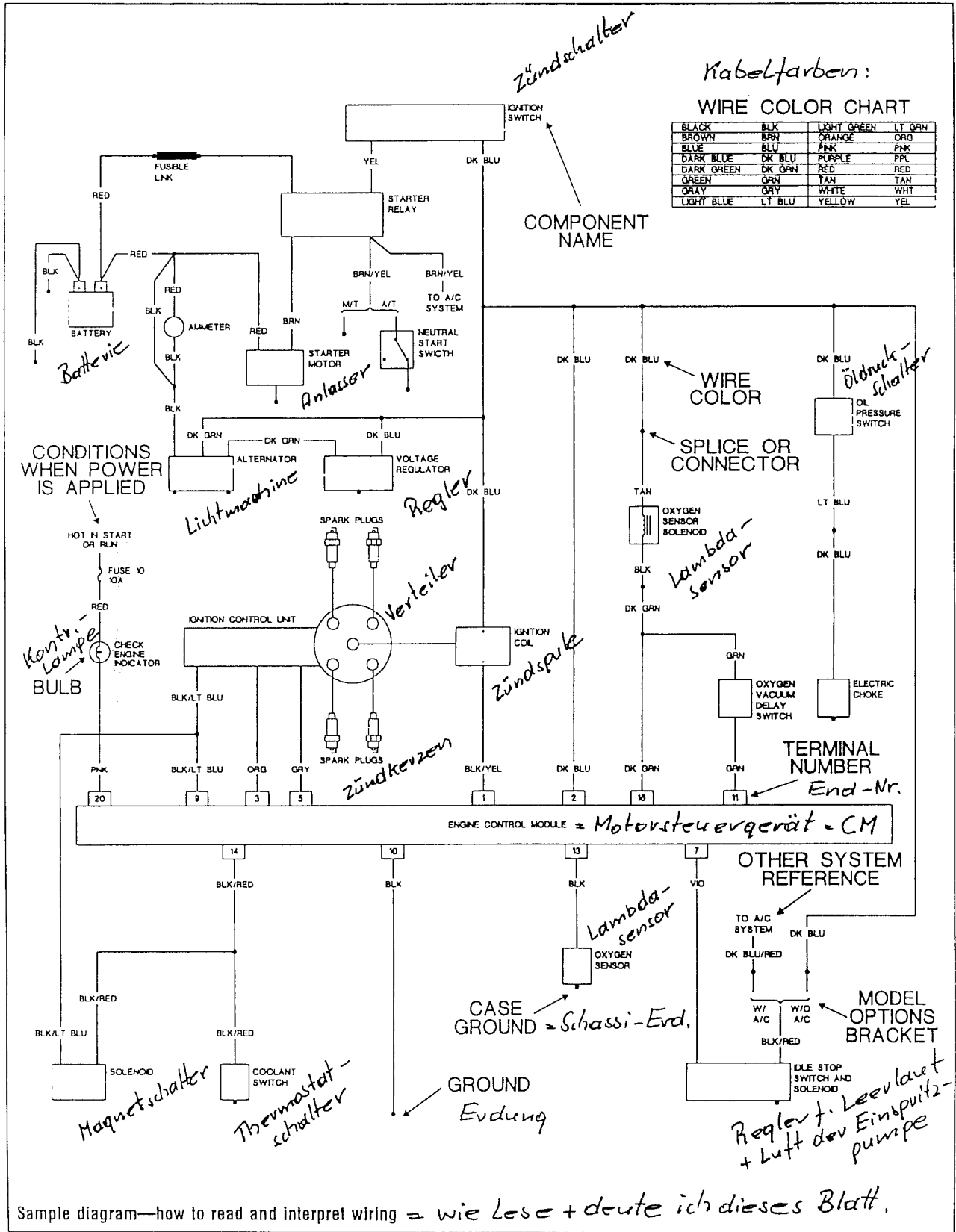

Elektrische Stromkreisverteilung

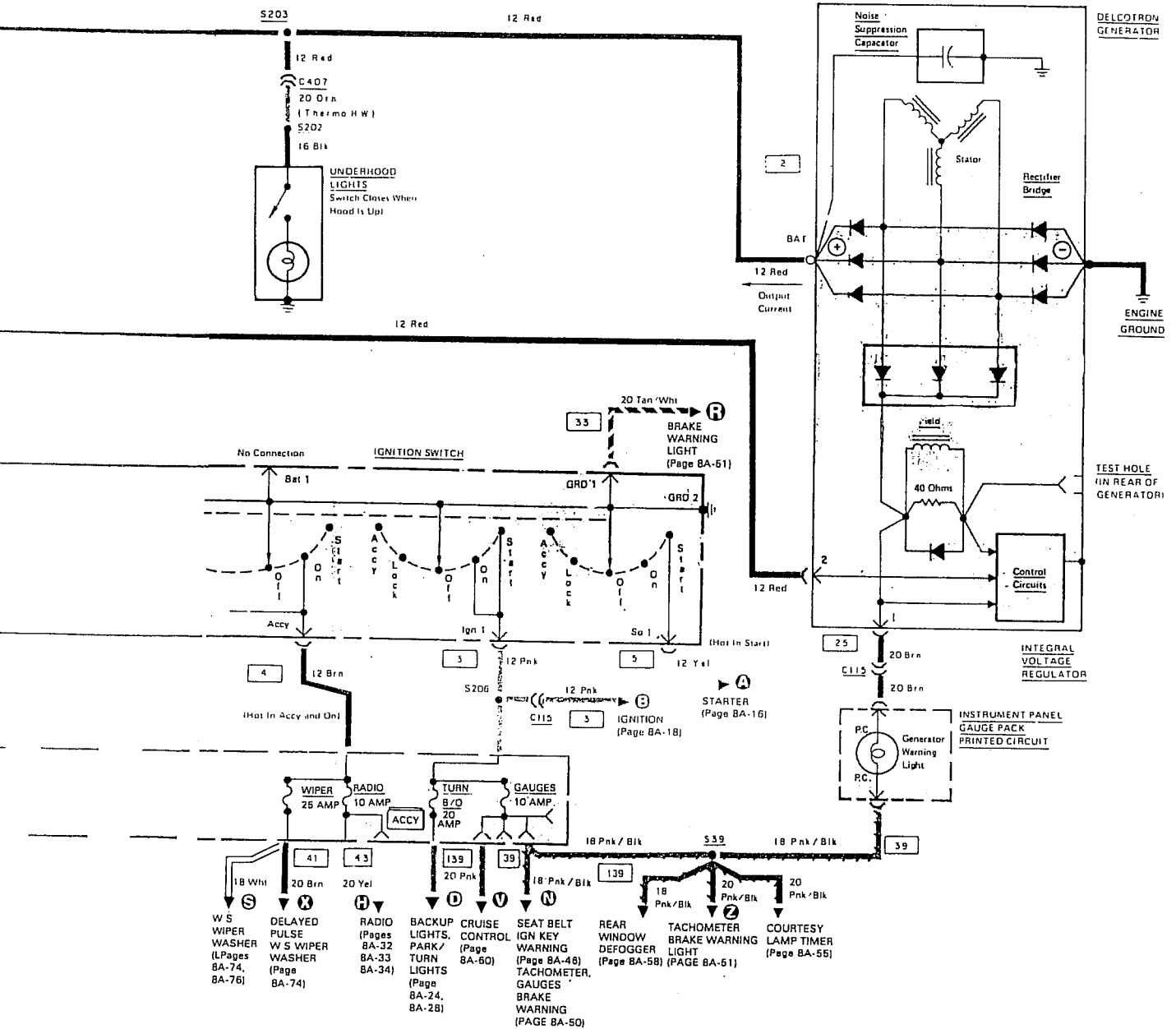

Motor anlassen.

Zündschloß

From Ignition Switch
Hot in Start Only
(Figure 8A-8)

CLUTCH START SWITCH
(Manual Transmission)
Closed with Clutch Down

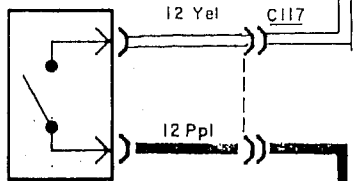

NEUTRAL SAFETY SWITCH
(Automatic Transmission)
Closed in Neutral or Park

5 12 Yel

6 12 Ppl

12 Yel

C117

12 Ppl

12 Ppl

C115

12 Ppl

C403

12 Ppl

For Other Circuits See
Power Distribution Circuit
(Figure 8A-8)

0 Blk 2

BATTERY

Batterie

SOLENOID SWITCH

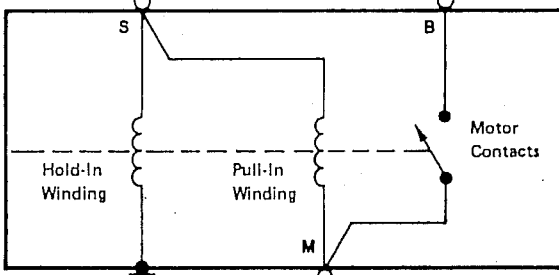

SHIFTER

DRIVE MECHANISM

STARTER MOTOR

Anlasser

ENGINE

Getriebe

ENGINE GROUND

Masse

Motor

Zündung

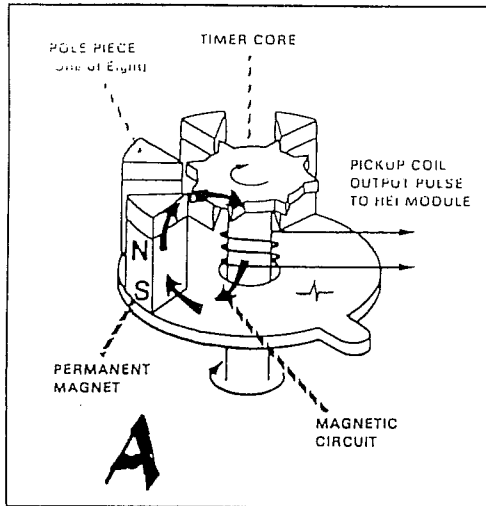

From Ignition Switch
Hot in START or ON
(Figure 8A-8)

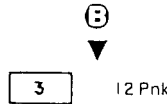

RADIO
NOISE
CAPACITOR

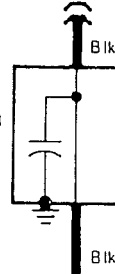

18 Wht → To Tachometer
(Page 8A-50)

C115

18 Wht
121

CAUTION:
Permanent Damage Can
Occur to the HEI Module
and Ignition Coil if Circuit
121 is Grounded.

Secondary Resistance:
6,000 to 30,000 ohms

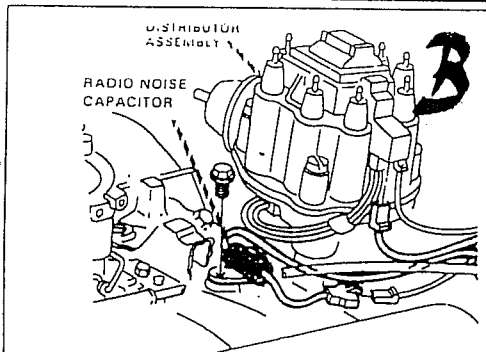
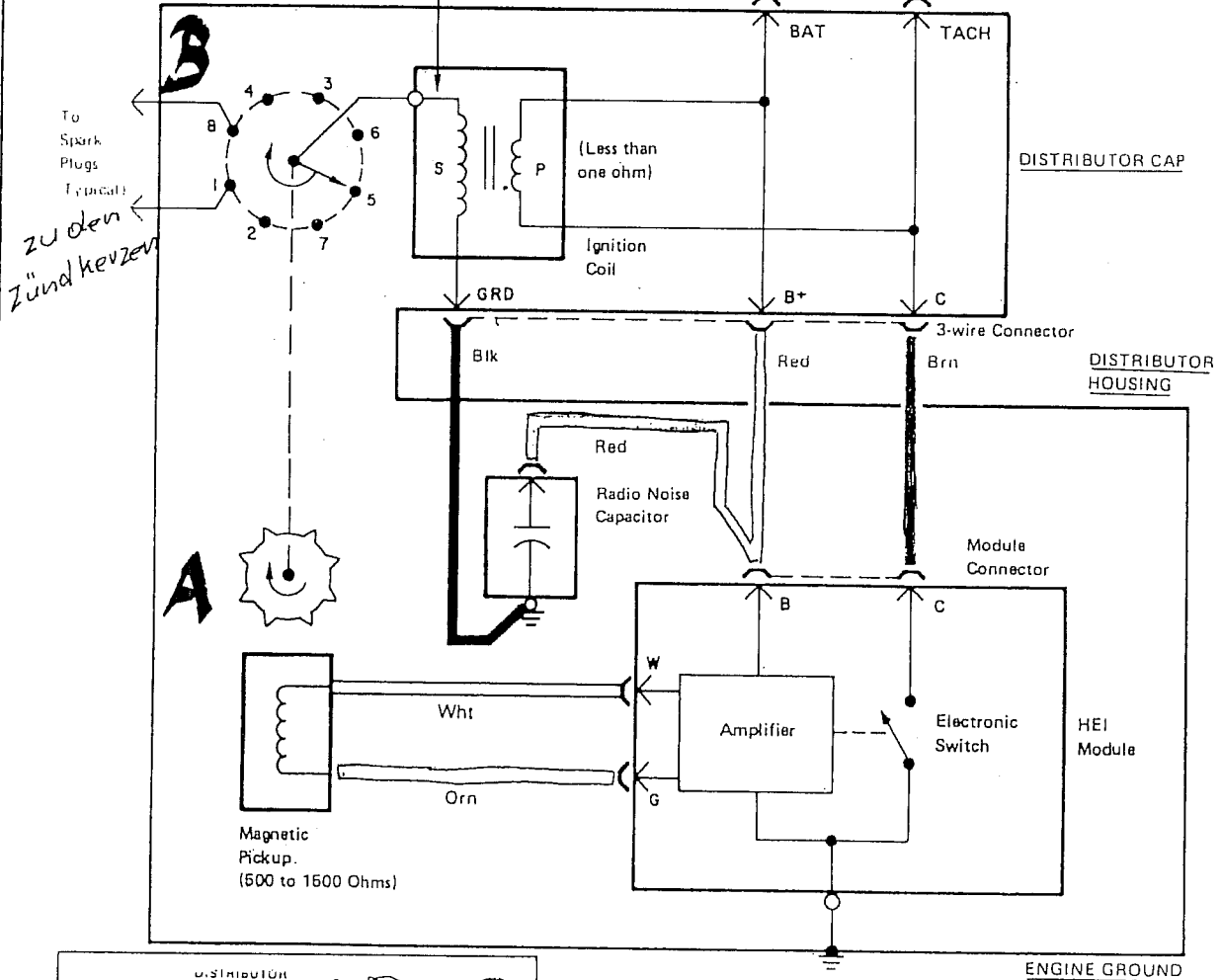

Scheinwerfer

From Starter Motor (see figure 8A-8)
Hot At All Times

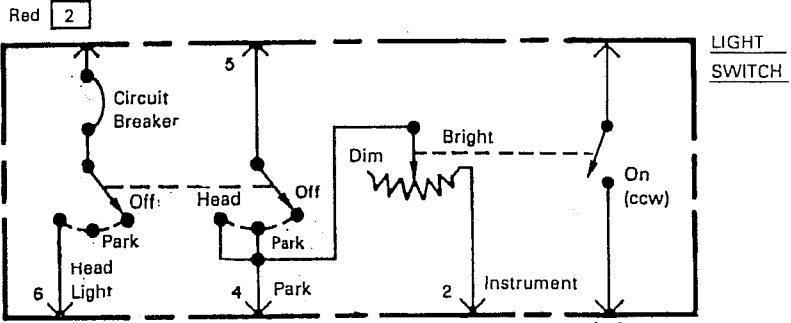

10 14 Yel

12 Blk
S225
12 Blk
INSTRUMENT PANEL GROUND
(On Left Hinge Pillar, Above Courtesy Light)

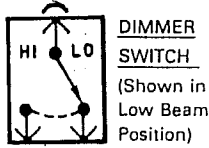

SPEEDOMETER/TACHOMETER INSTRUMENT CLUSTER PRINTED CIRCUIT

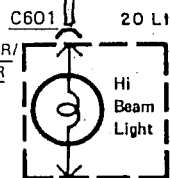

14 Blk C601
12 Blk S225

INSTRUMENT PANEL GROUND
(On Left Hinge Pillar, Above Courtesy Light)

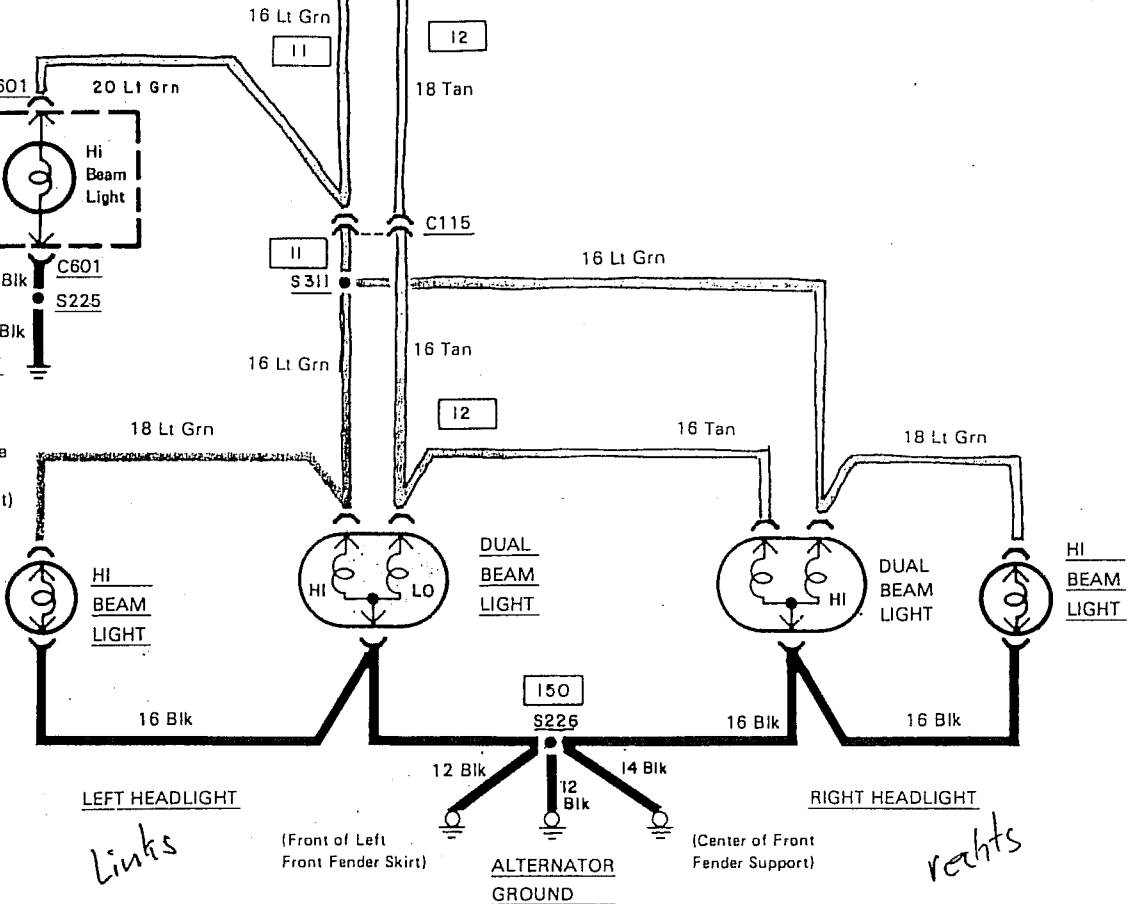

Rücklichter

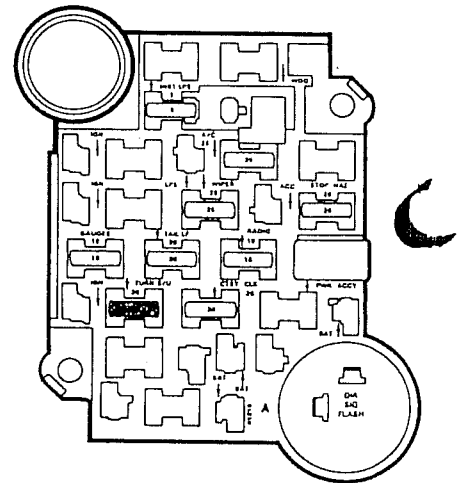
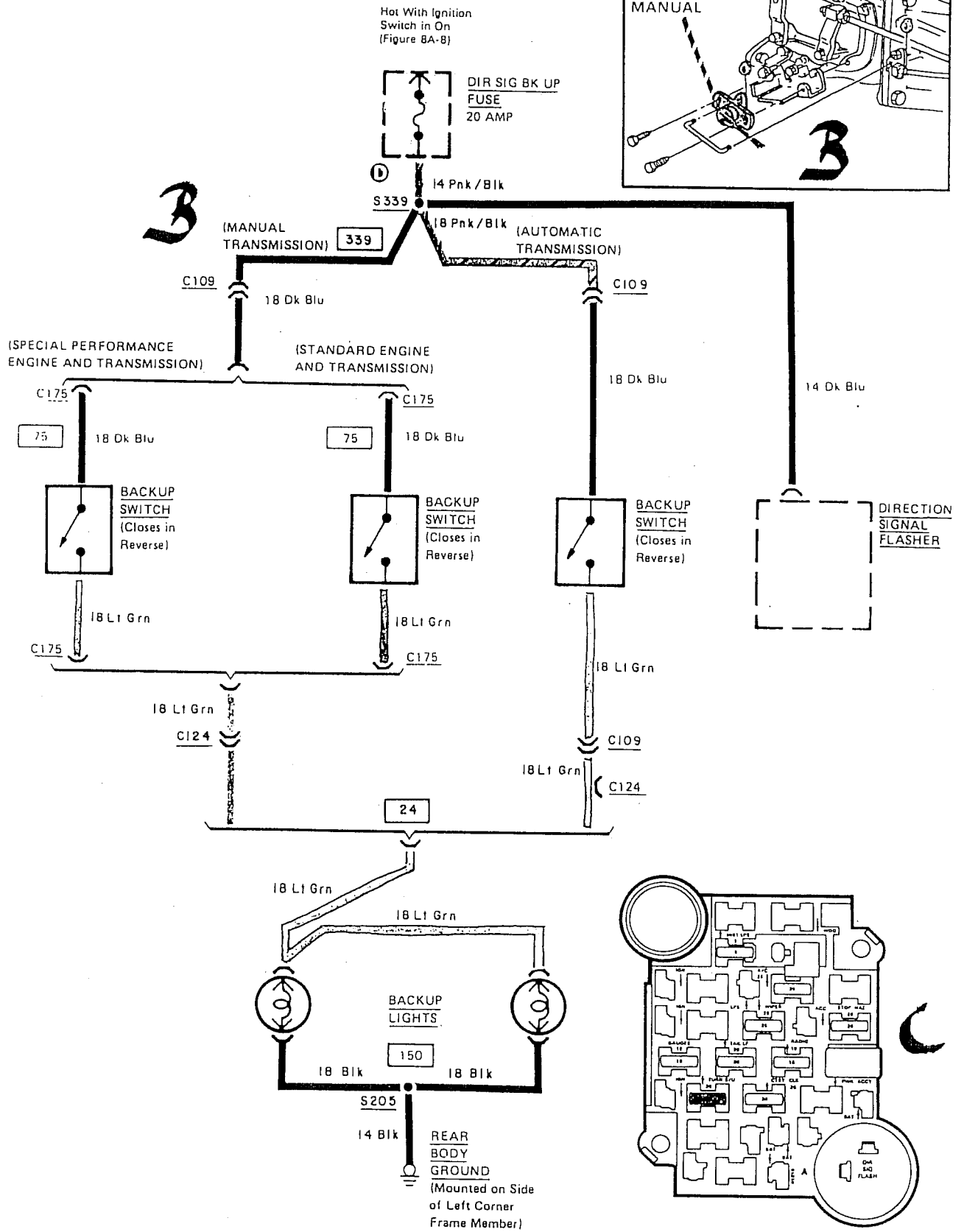
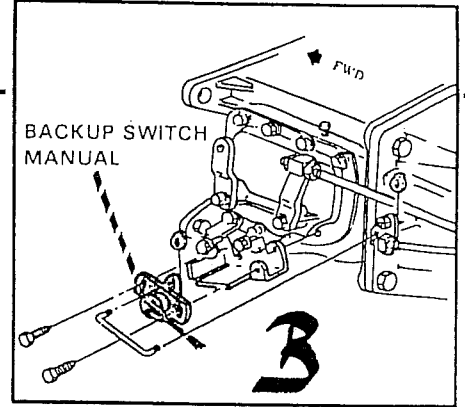

C = Sicherung

Rückleuchten: Parklicht Nr.-Schild-Bel. Stoplichter

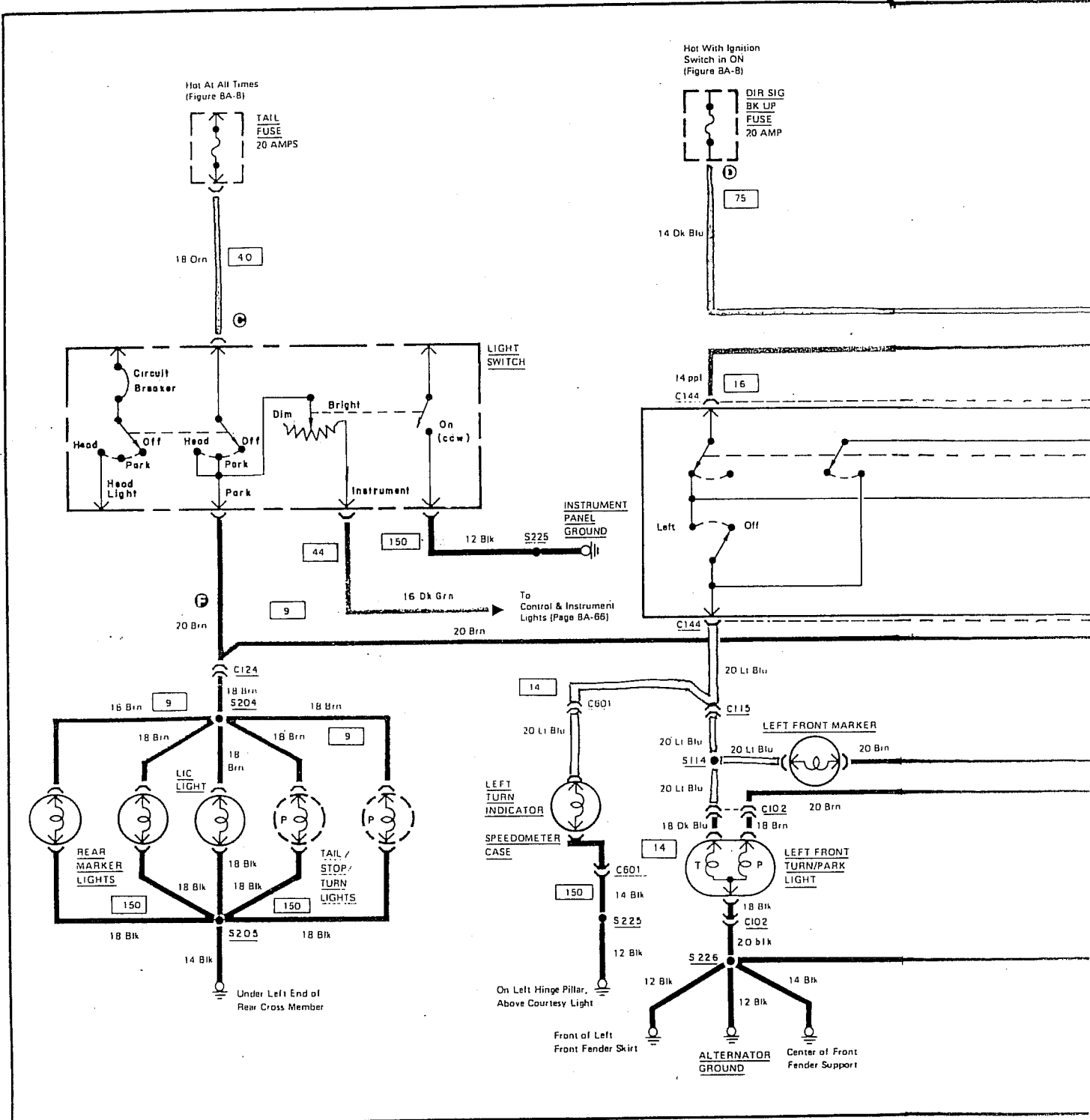

Hindernis-Warnung Blink Leuchten

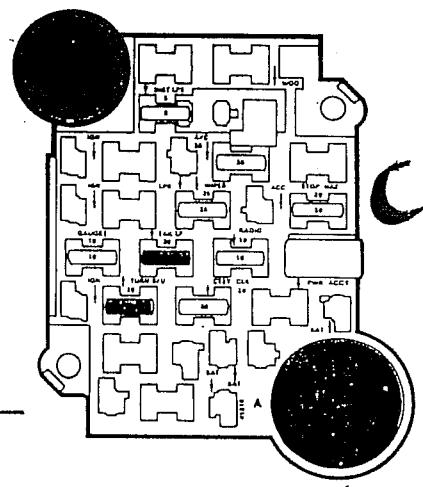

- A** = Warnblink-Relay
- B** = Blinker-Relay
- C** = Sicherung = Rückleuchten

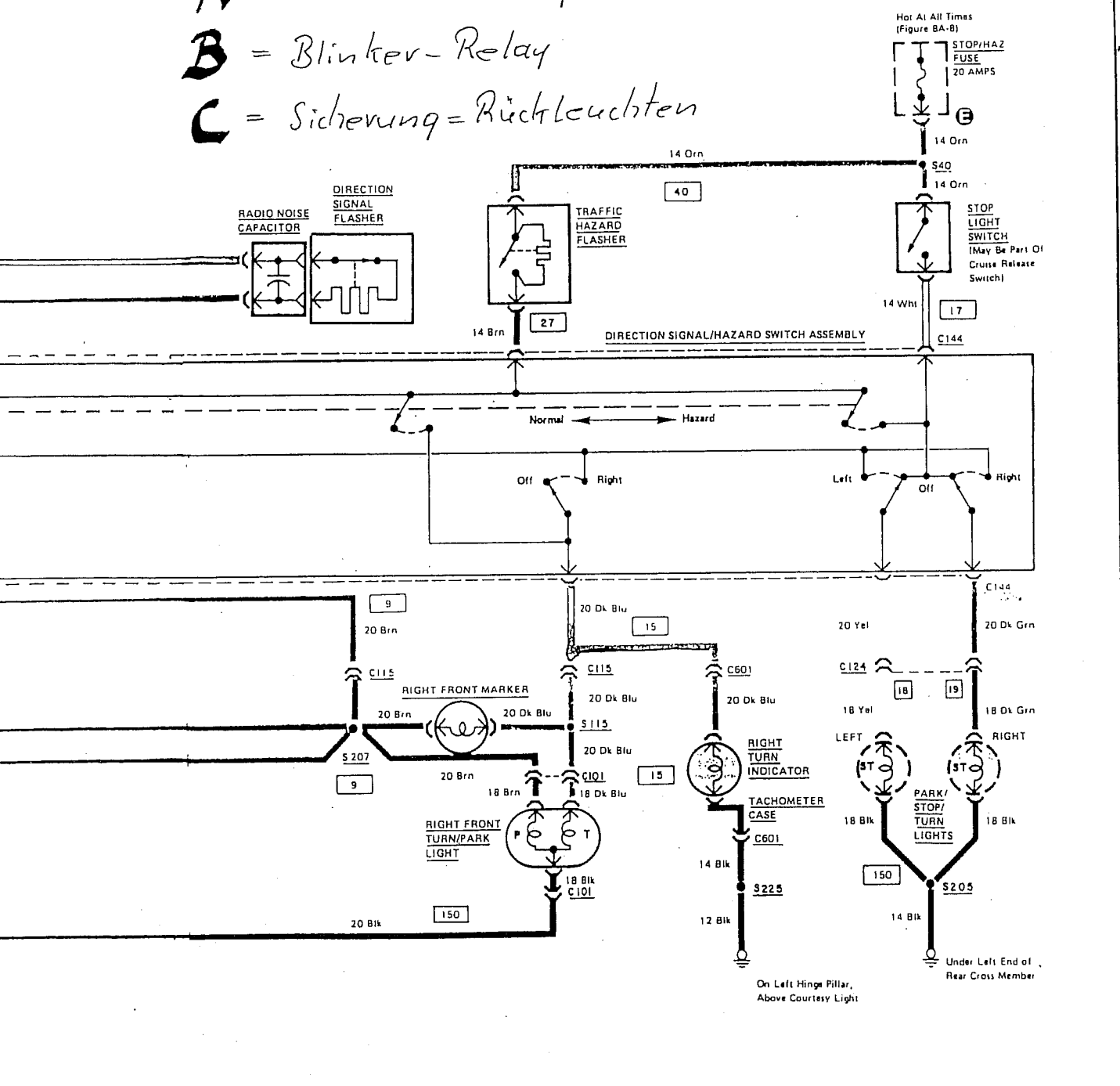

Elektr. Antenne

Hot With Ignition Switch
In ACCY and ON
(Figure 8A-8)

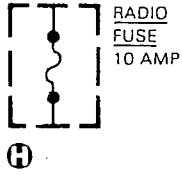

43 20 Yel

Hot At All Times
(Figure 8A-8)

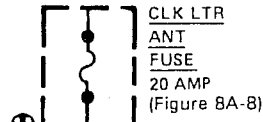

140 C115

S140

14 Orn

C140

18 Orn

40

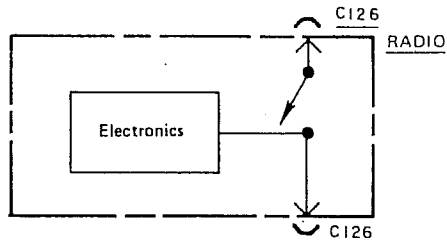

18 Yel

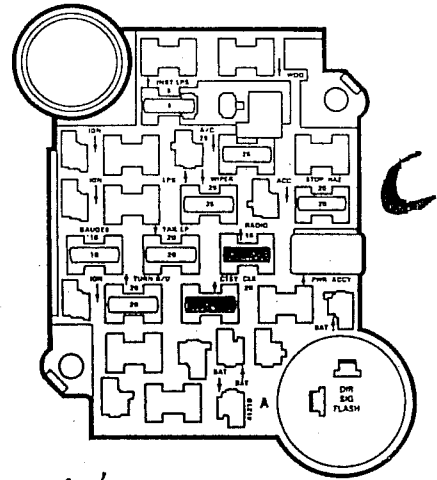

C = Sicherungen

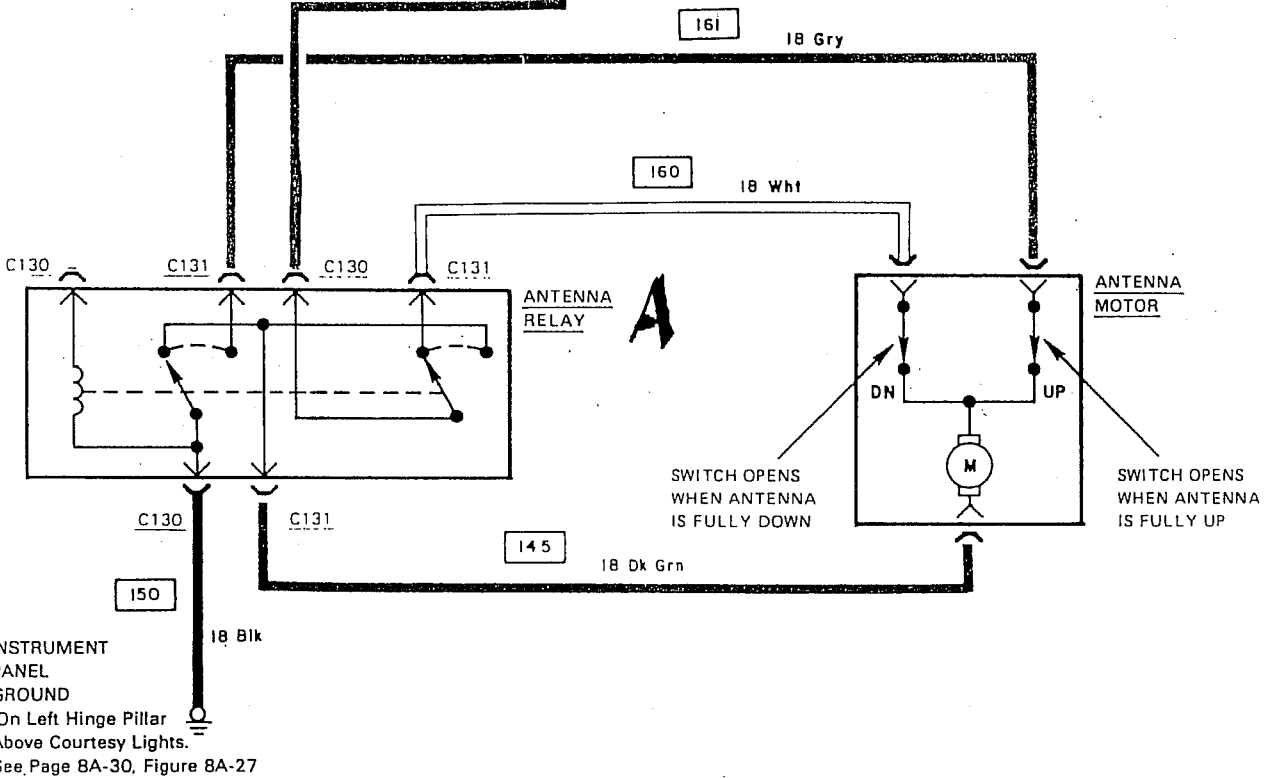
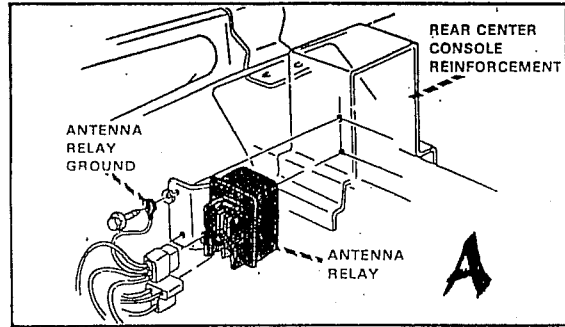

Heizgebläse

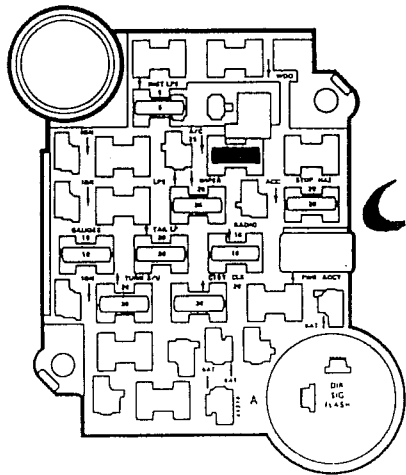

C = Sicherung

Hot With Ignition Switch in ON (Fig. 8A-8)

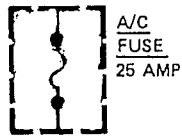

50 14 Brn

C125

14 Brn

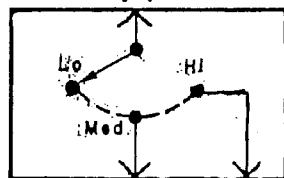

BLOWER SWITCH B

51 14 Yel

72

52

14 Orn

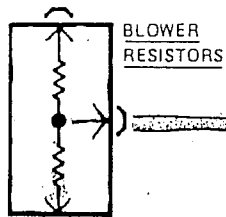

BLOWER RESISTORS

14 L1 Blu

52 14 Orn

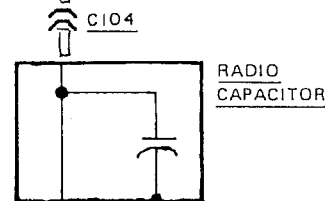
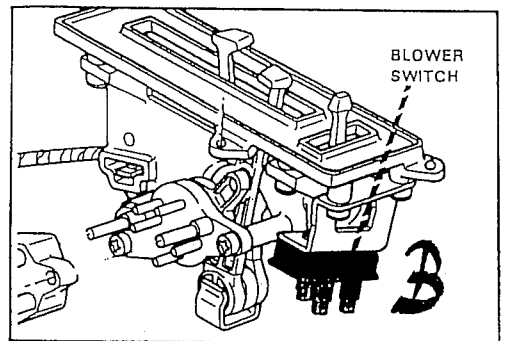
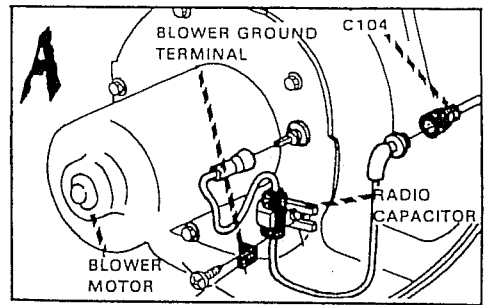

RADIO CAPACITOR A

52 14 Orn

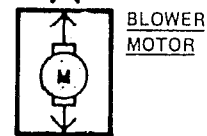

BLOWER MOTOR

150 16 Bik

C103

14 blk

C403

14 blk ENGINE GROUND

Heizung und

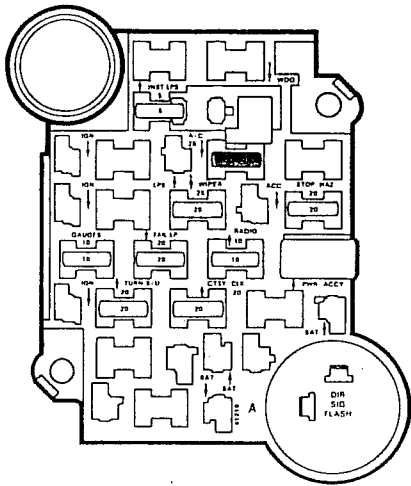

Sicherung

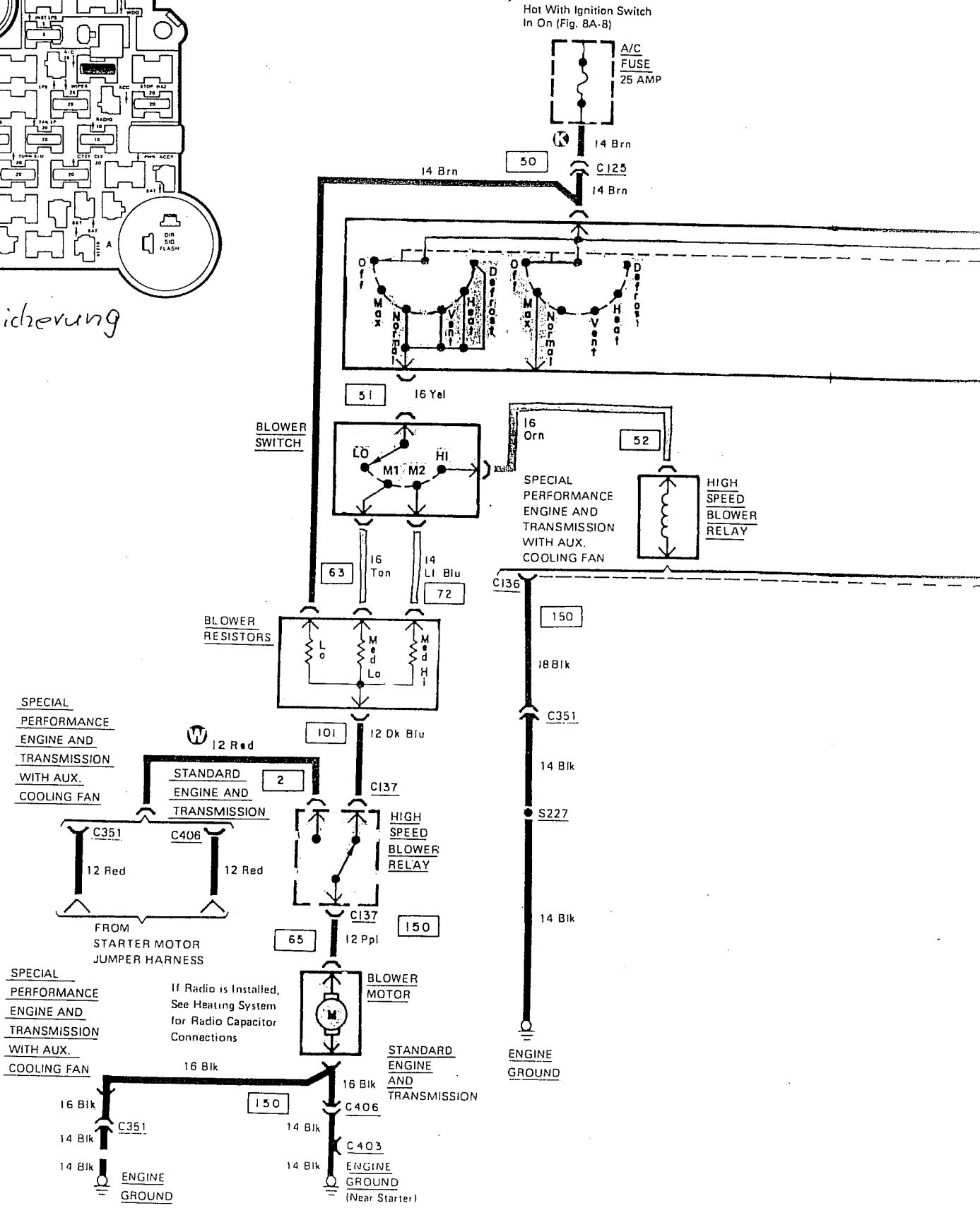

Klimaanlage

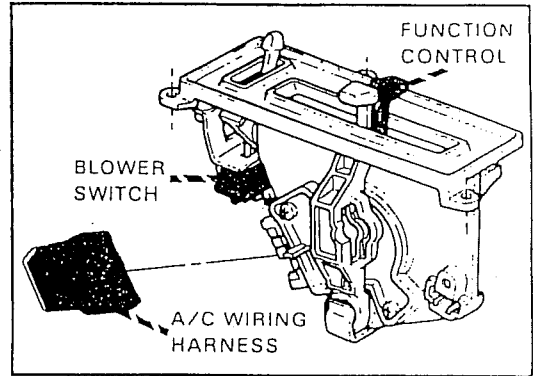

FUNCTION CONTROL SWITCH
(Vacuum Section Not Shown)

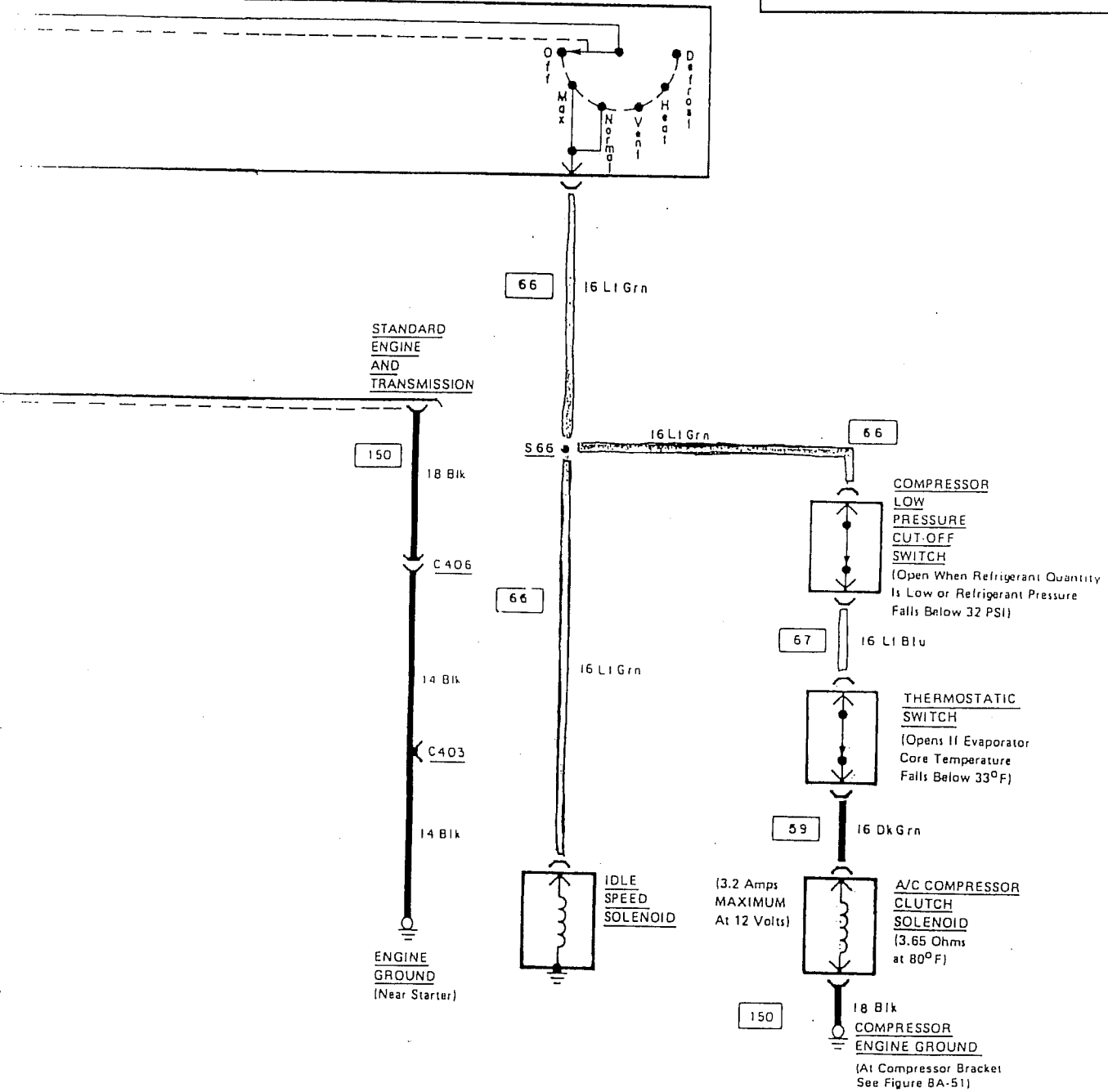

Hot With Ignition Switch
in START or ON
(Figure 8A-8)

Tempomat

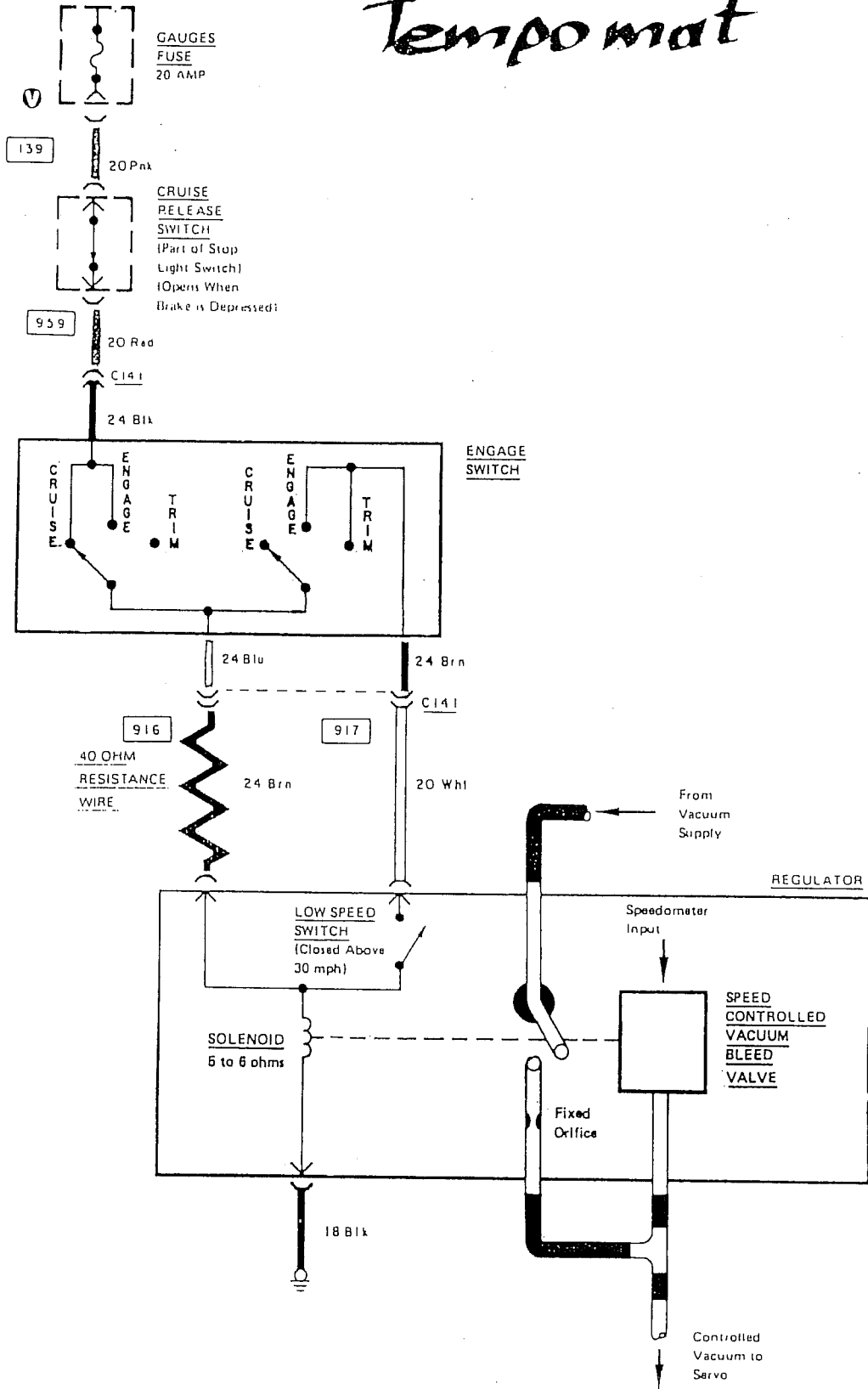

Kontrollleuchten:

Öl
Wasser
Volt
Benzin

Hot With Ignition Switch
In START Or ON
(Figure 8A-8)

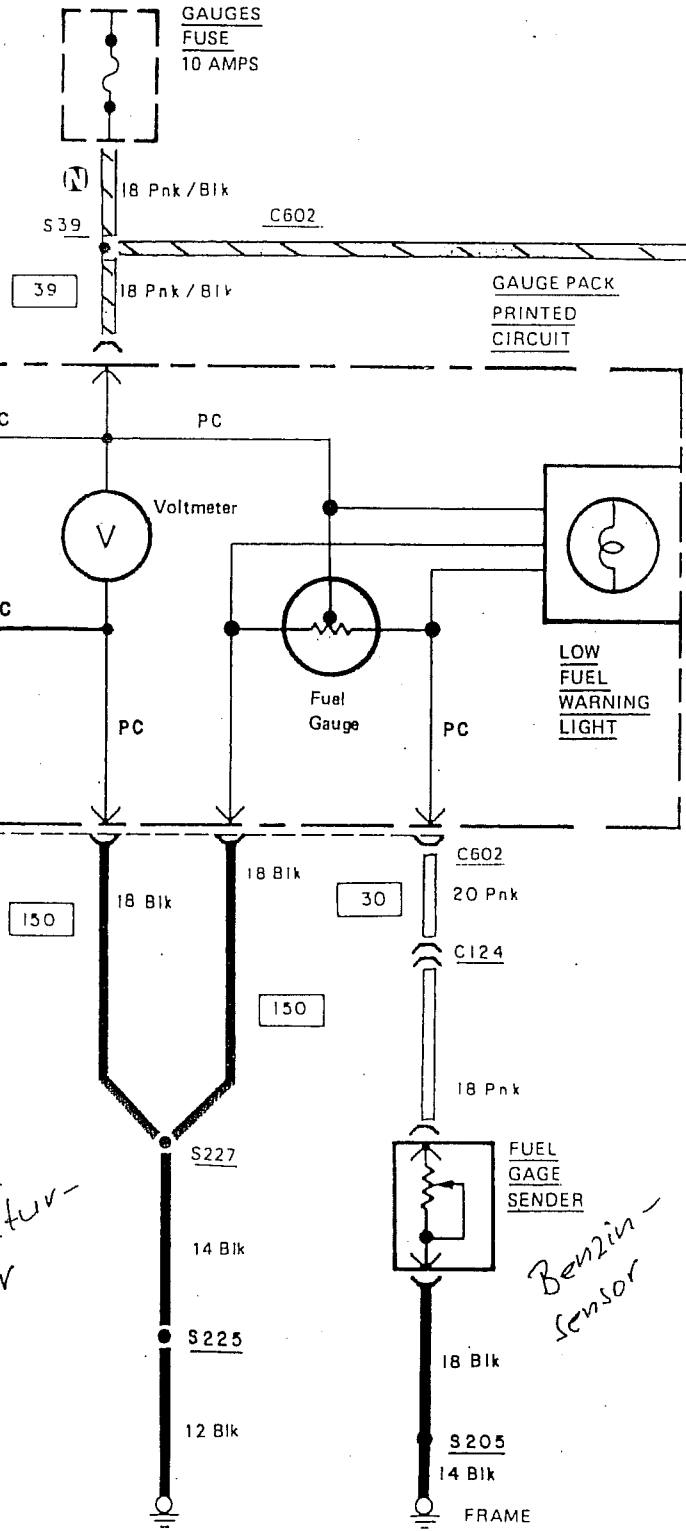

Tacho, Handbremse, Bremschalter

SPEEDOMETER/TACHOMETER
INSTRUMENT CLUSTER PRINTED CIRCUIT

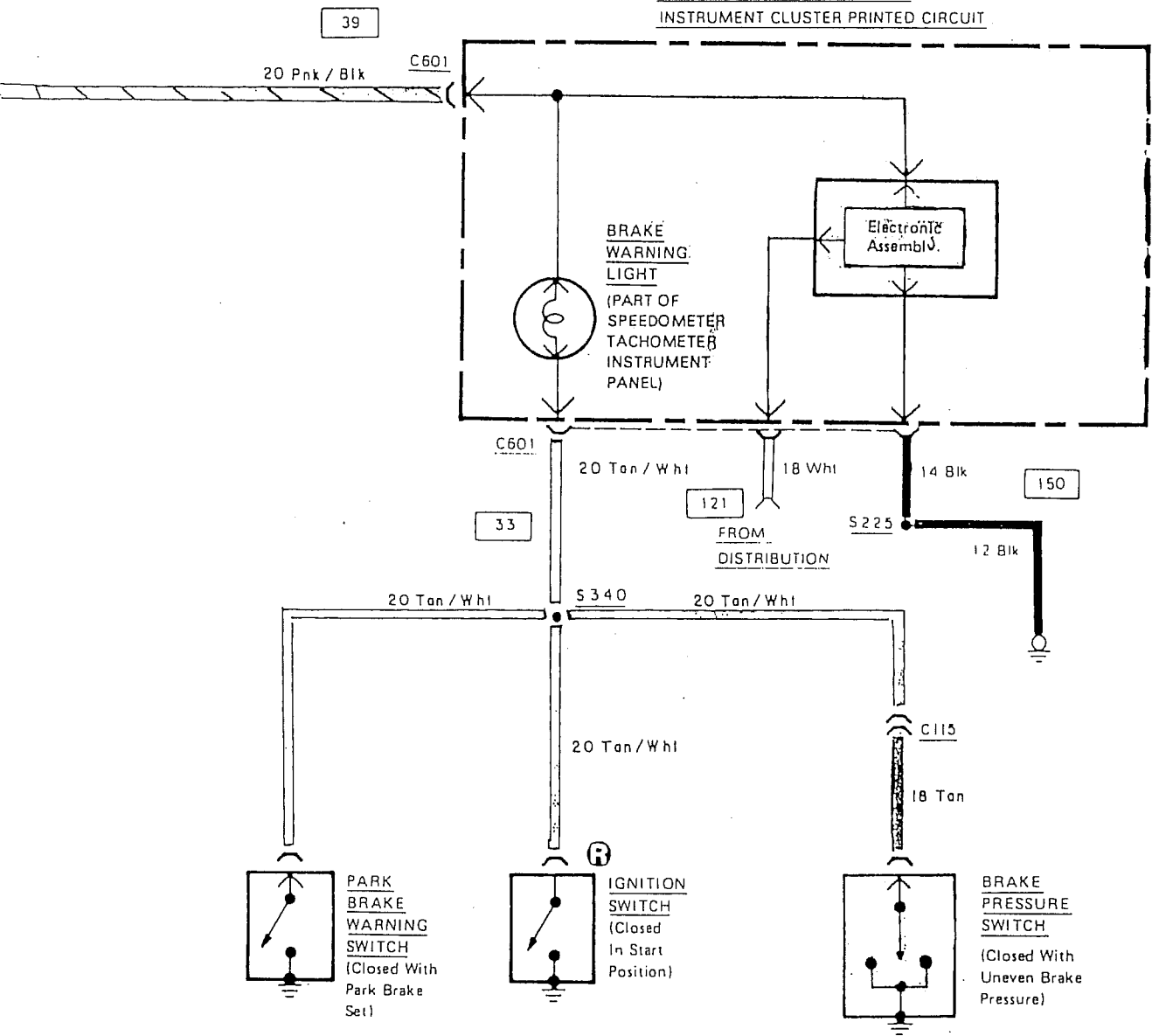

Beheizbare Heckscheibe +

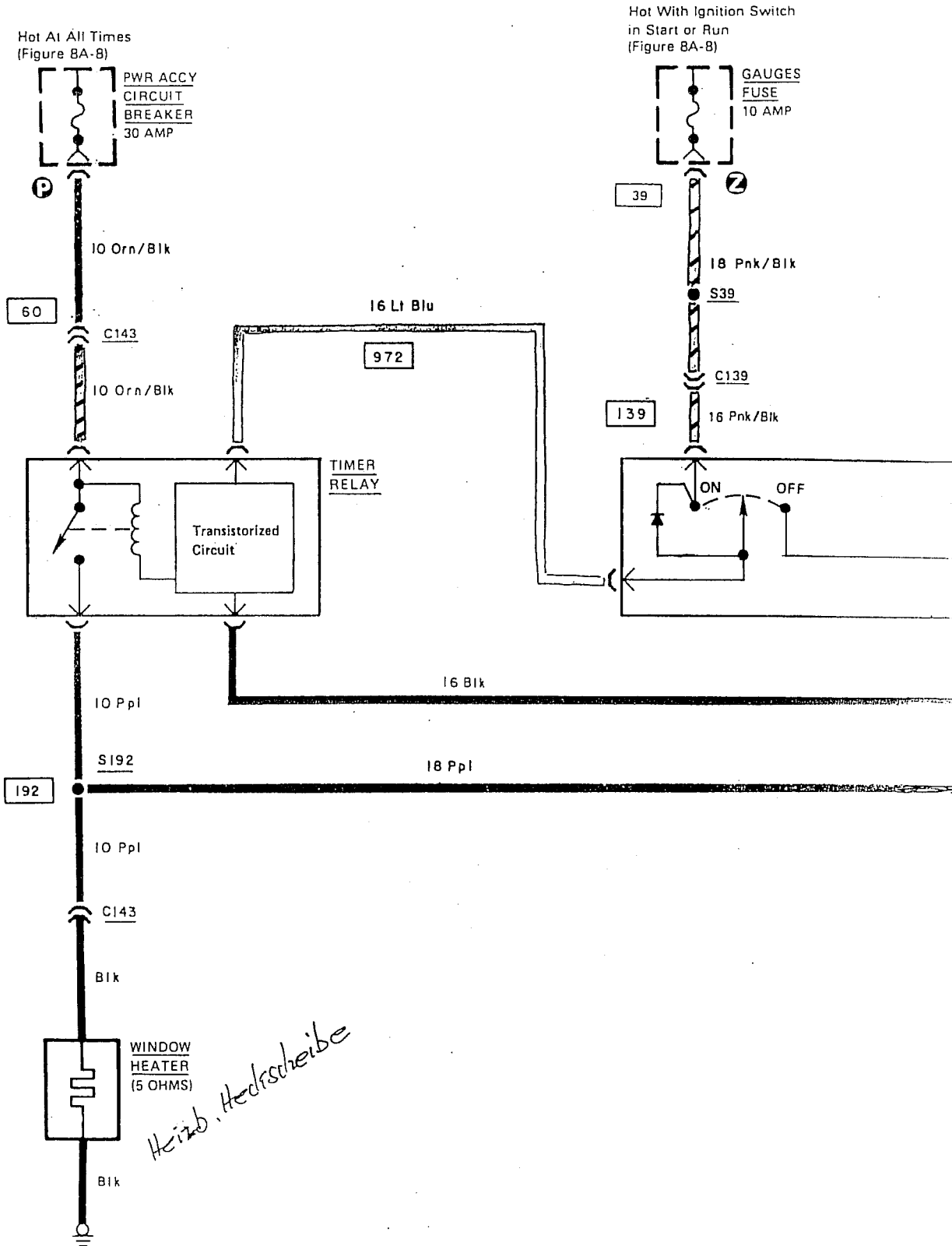

Nebelschlussleuchte

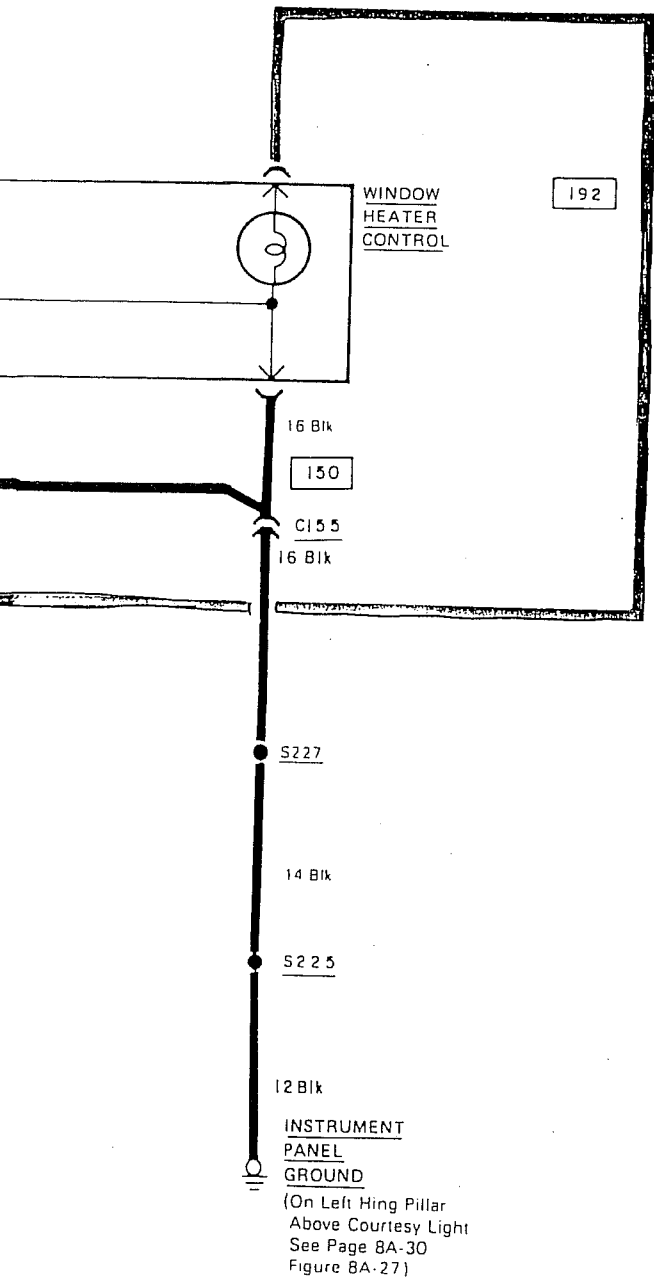

Hupe

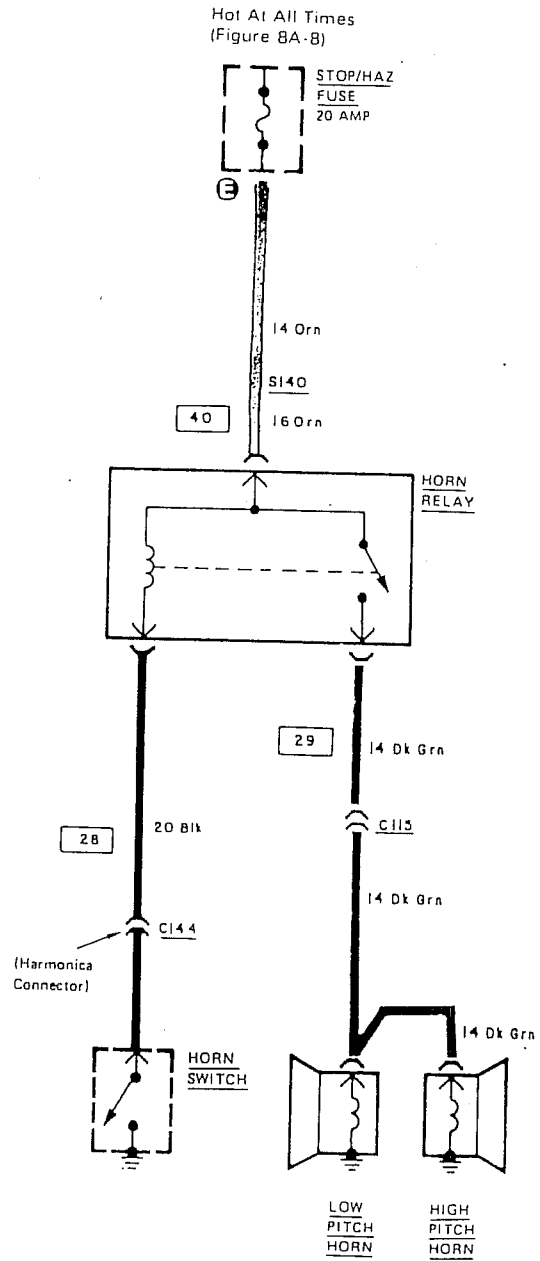

Tempomat - Kontrolle

Hot With Ignition Switch
in START or ON
(Figure BA-8)

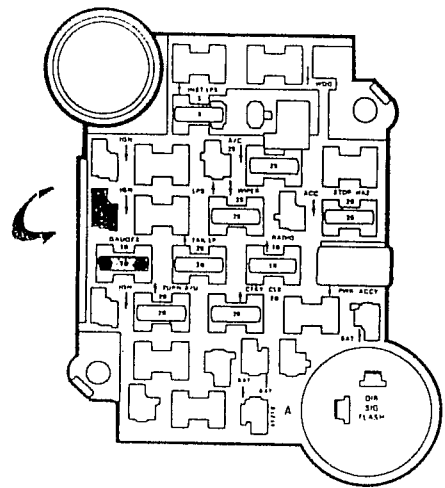
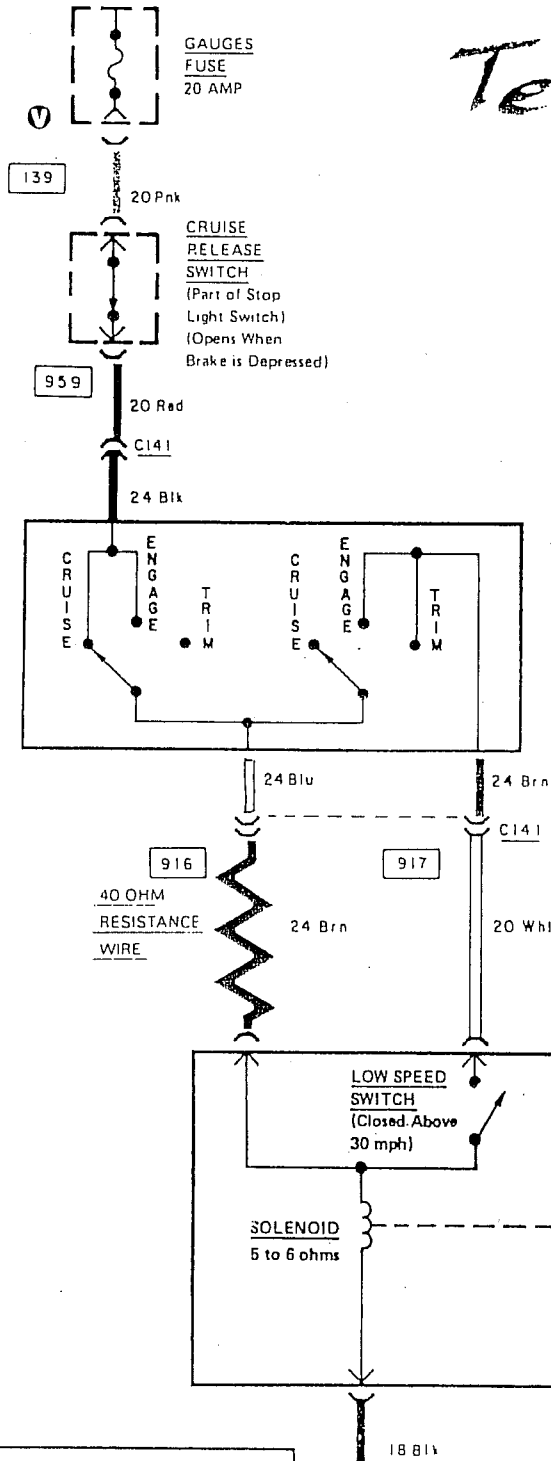

C = Sicherung im Sicherungskasten

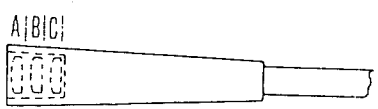
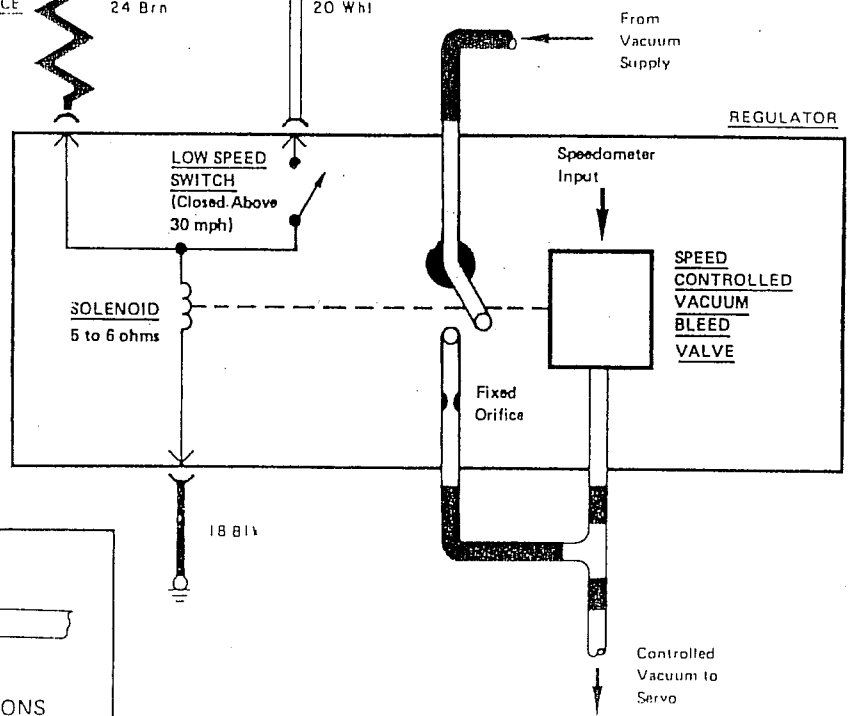

ENGAGE SWITCH POSITIONS

- A - CRUISE = Reise geschw.
- B - ENGAGE = Gas geben
- C - TRIM = Geschw. halten

Elektr. Fenster

C = Sicherung im Sicherungskasten.

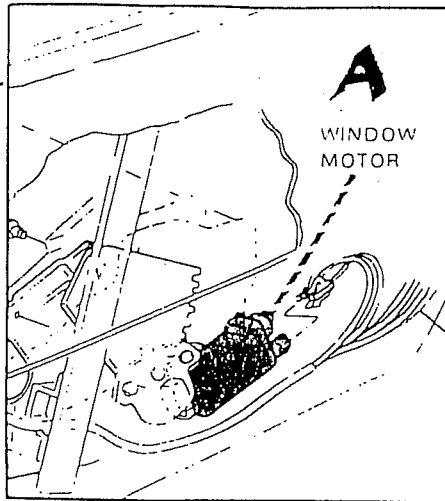
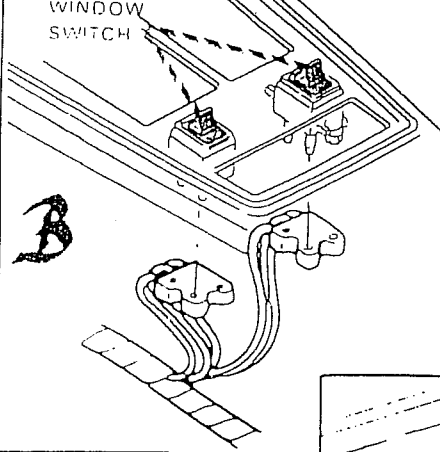

Hot At All Times
(Figure BA-8)

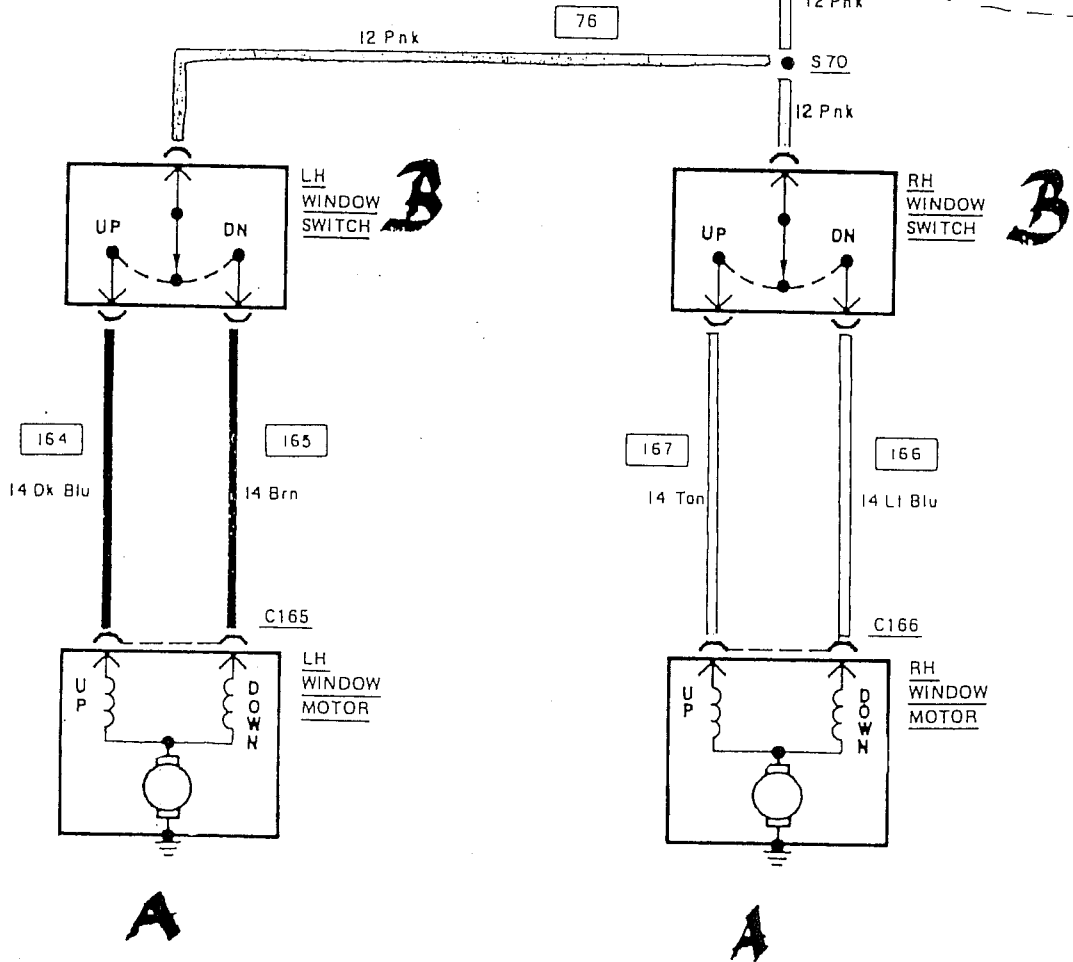
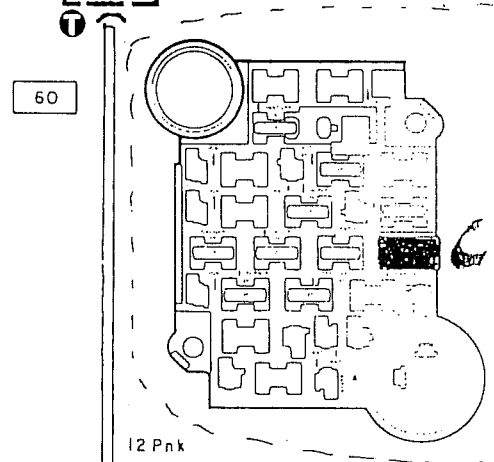

Instrumentenbeleuchtung

C = Sicherung im S₁-Kasten

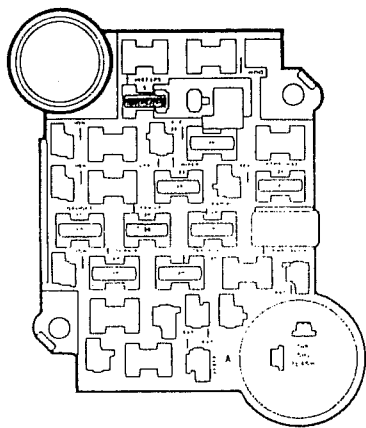

GAUGE PACK
PRINTED CIRCUIT

C602

SPEEDOMETER/TACHOMETER
INSTRUMENT PANEL
PRINTED CIRCUIT

20 Gry

C601

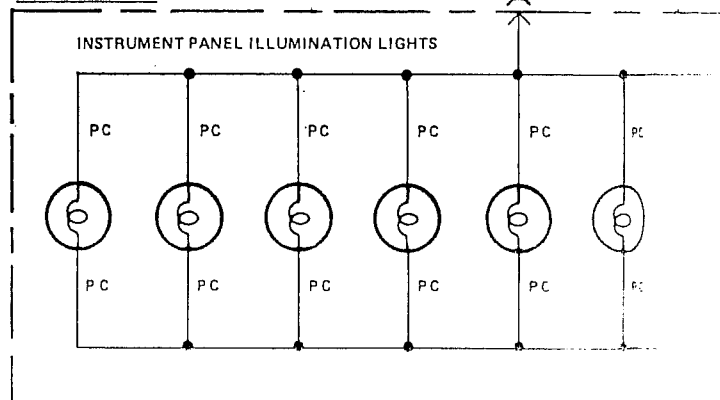
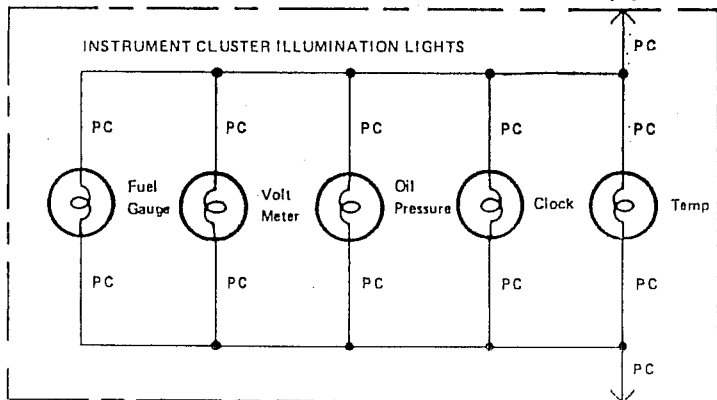

150

14 Btk

+ Kontrollleuchten

Hot At All Times
(From TAIL FUSE-Fig. 8A-B)

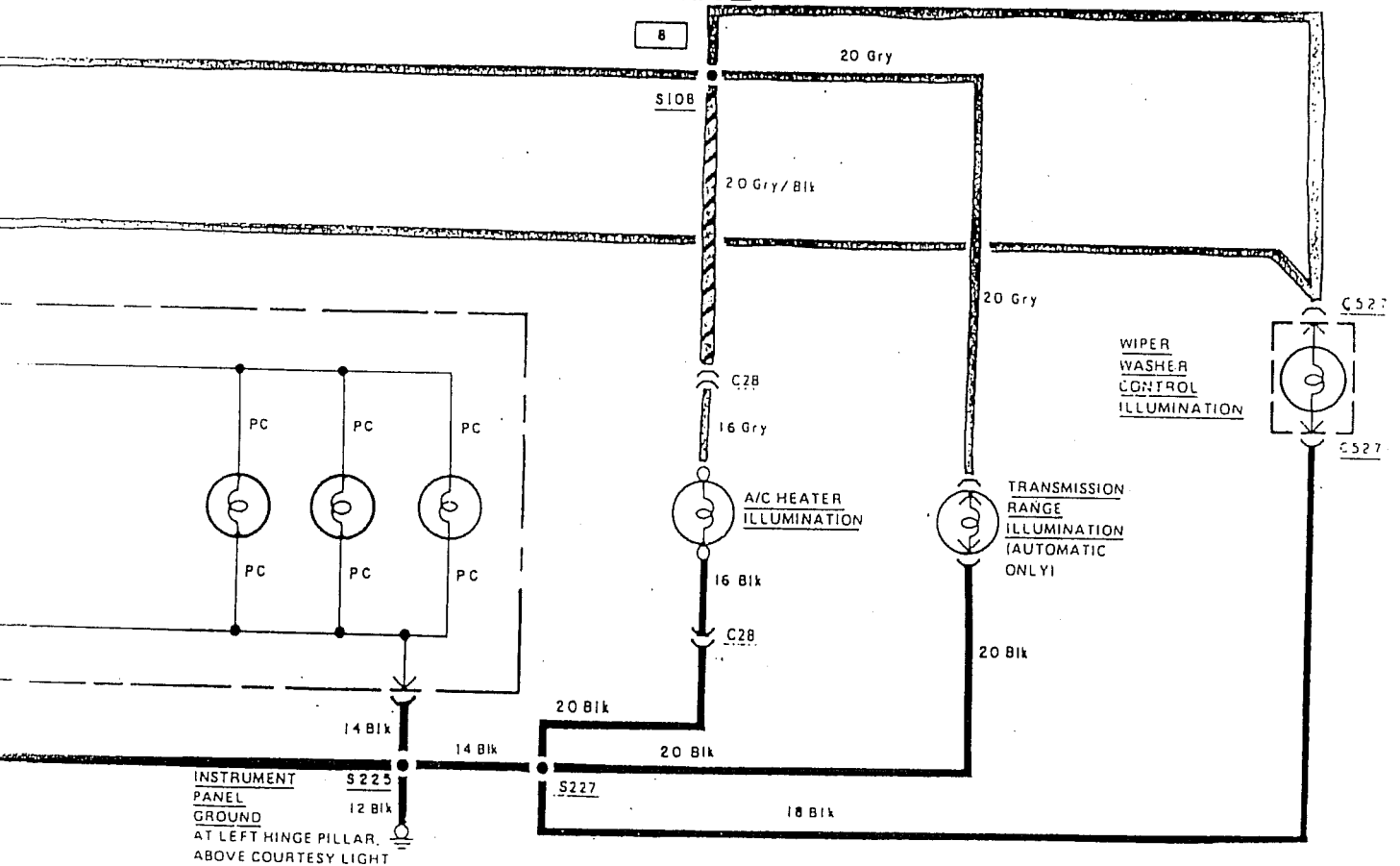
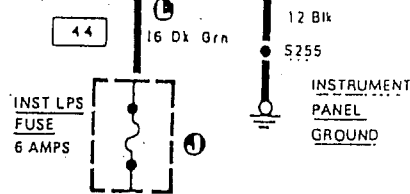
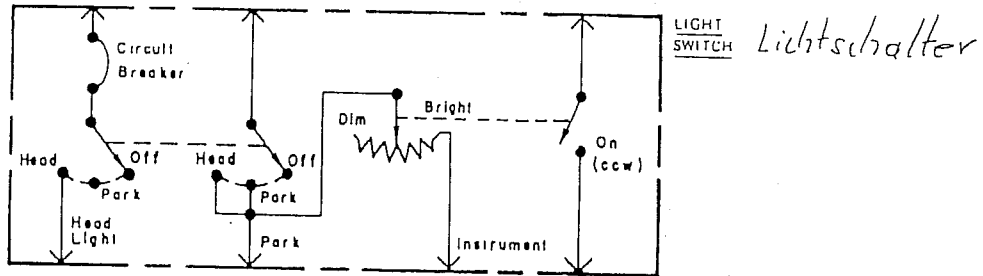

Hot At All Times
(Figure 8A-8)

Elektr. Türschlösser

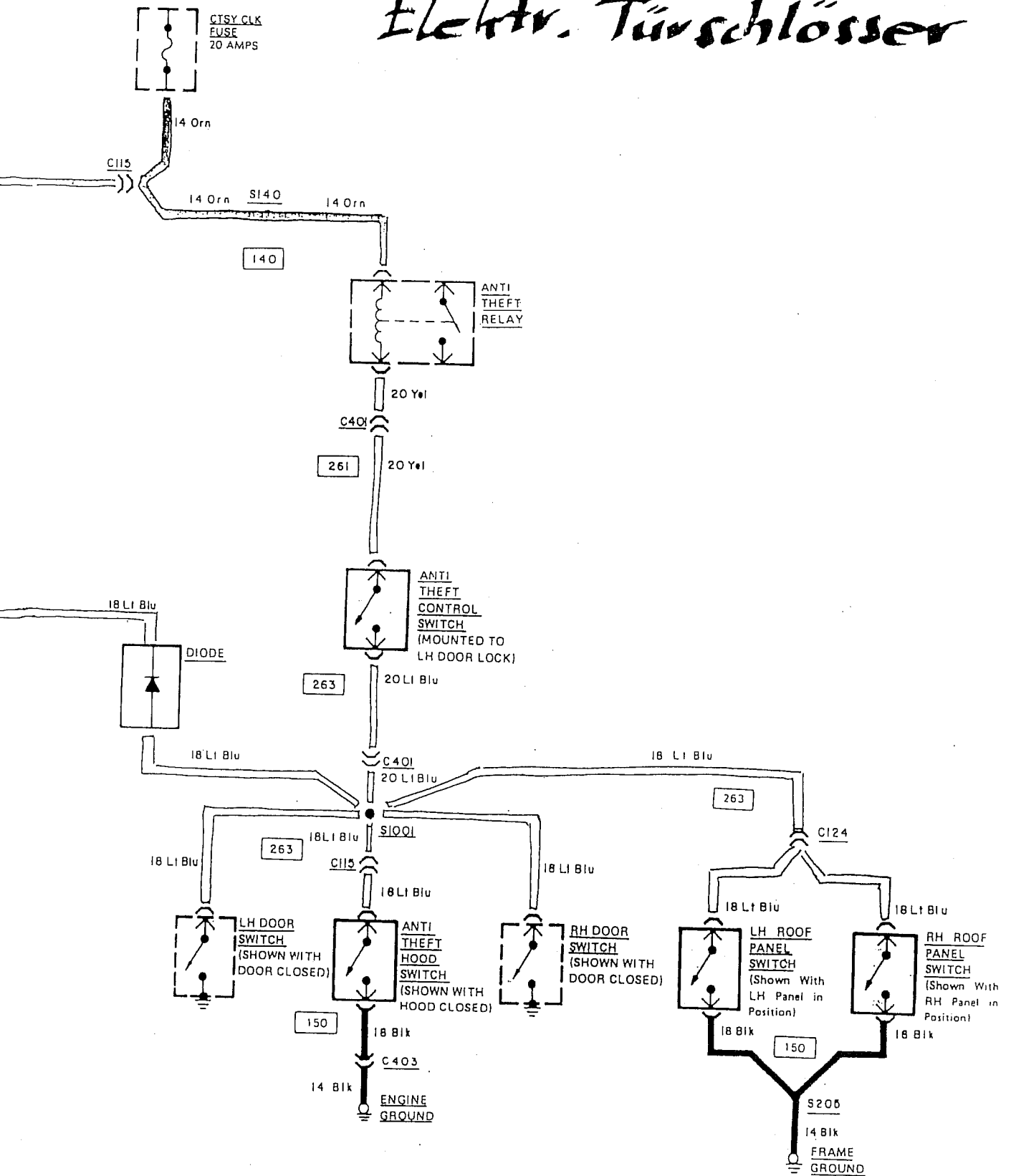

Intervall - Wischer + Wasch

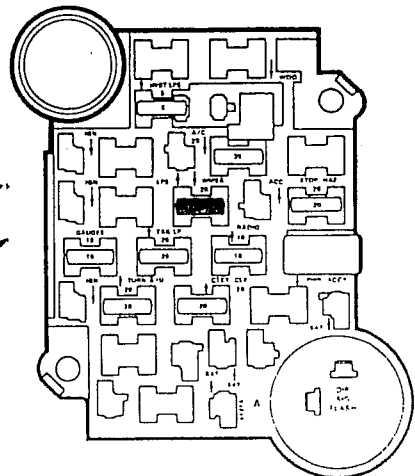

C = Sicherung im S.-Kasten

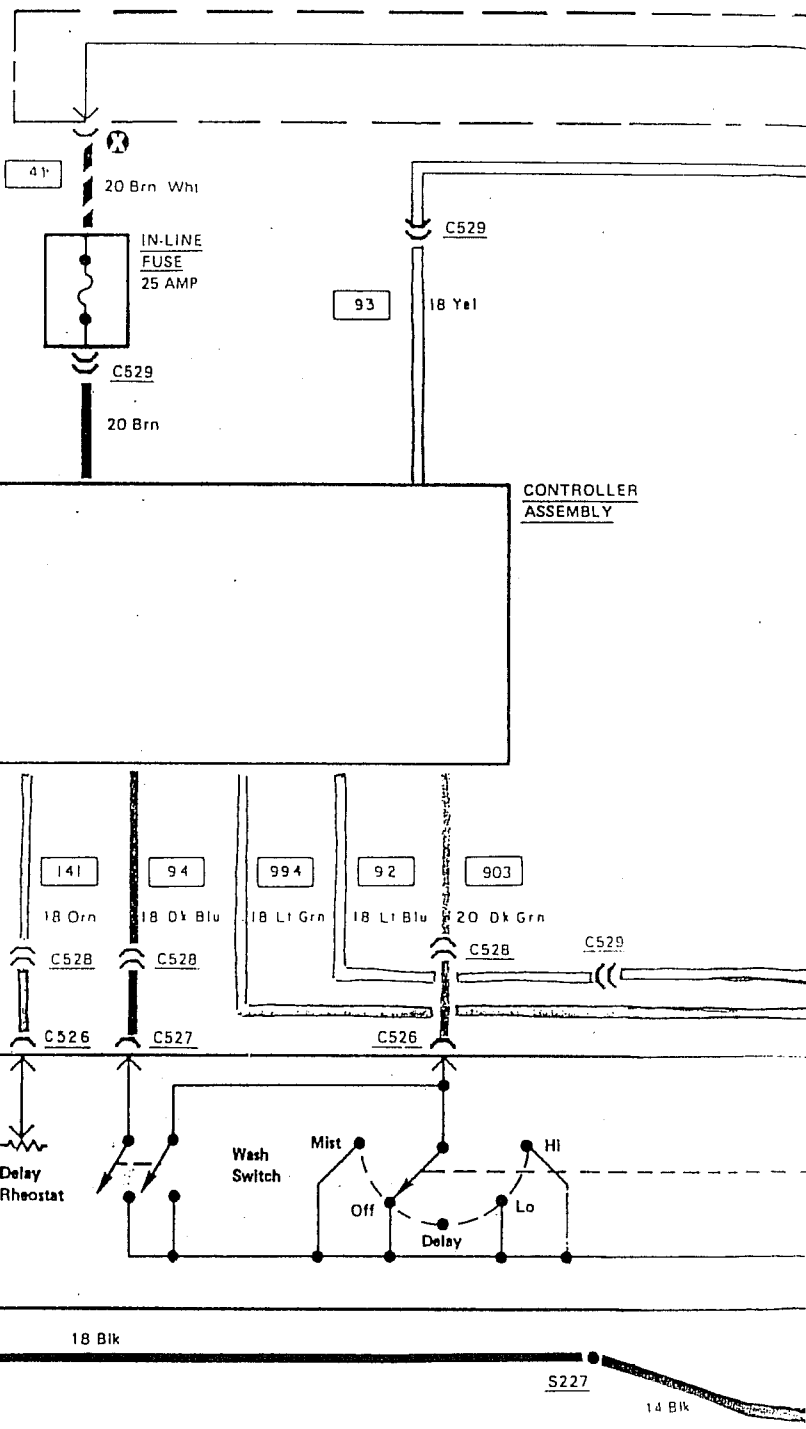

Anlage

A

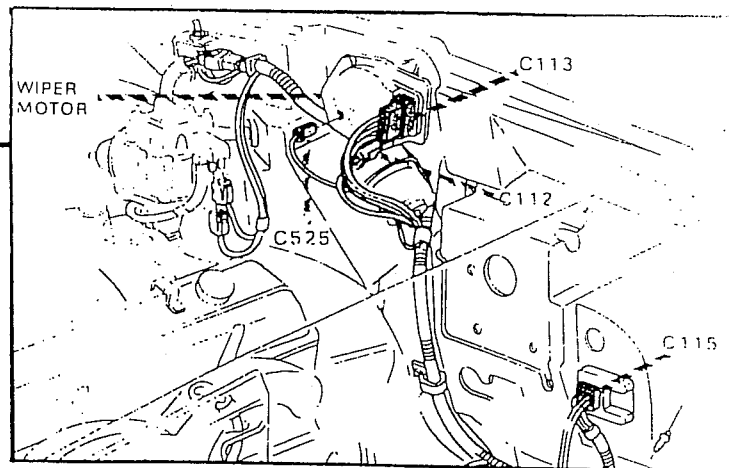

Hot With Ignition Switch
in ACCY or ON
(See Figure 8A-8)

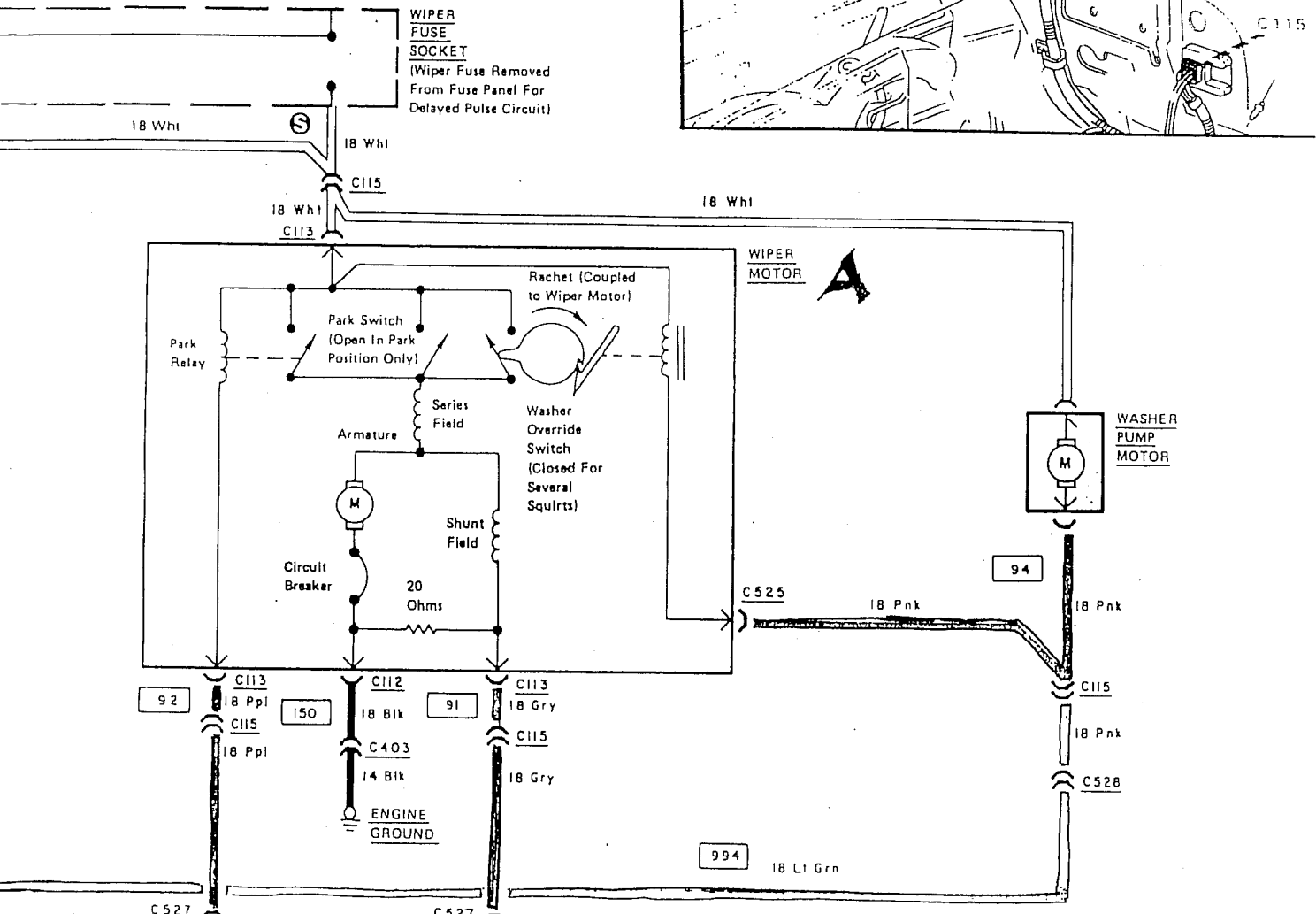

B

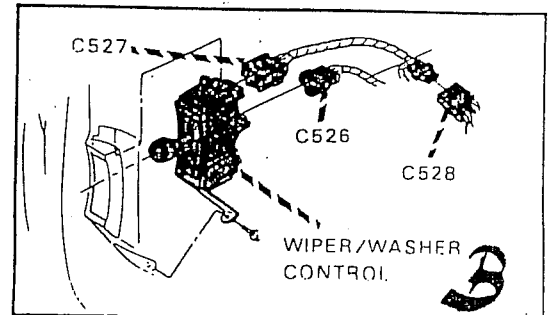
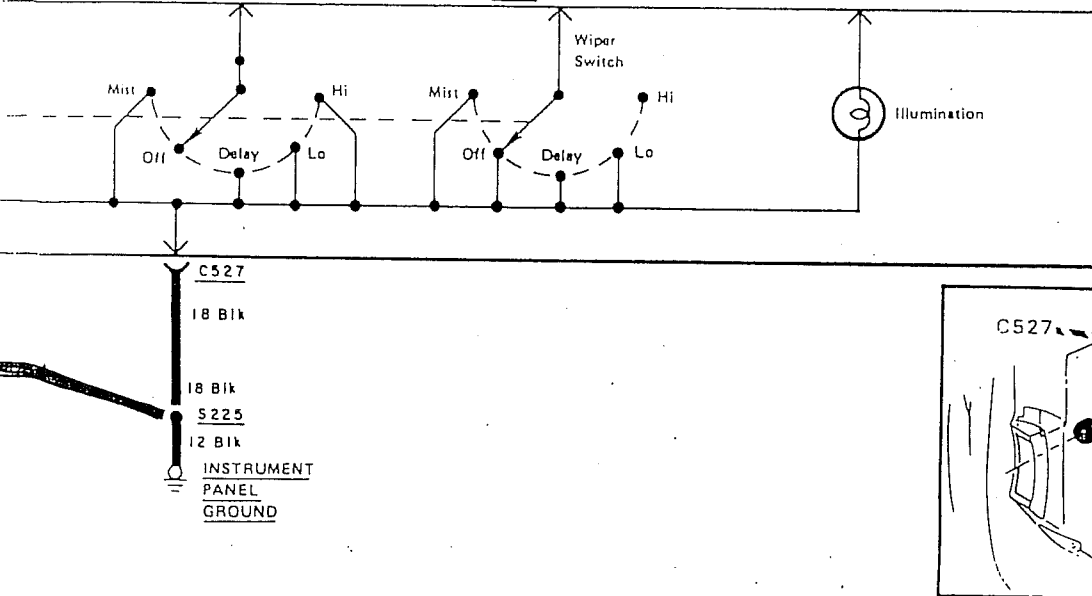

Scheibenwischer

Hot With Ignition Switch
In ACCY or ON

C = Sicherungskasten

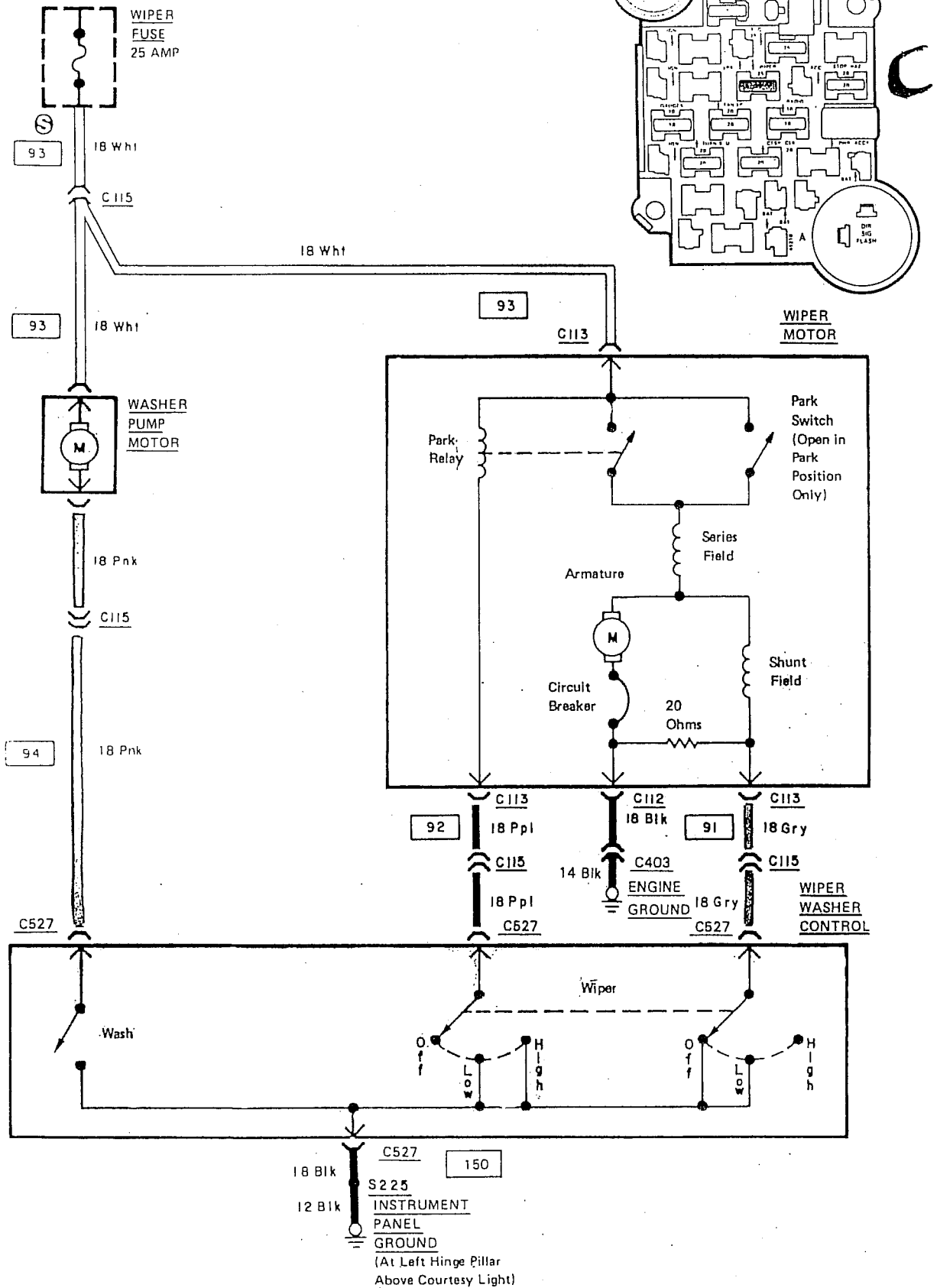

Gebläse

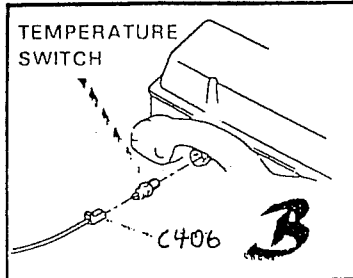
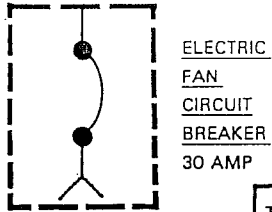
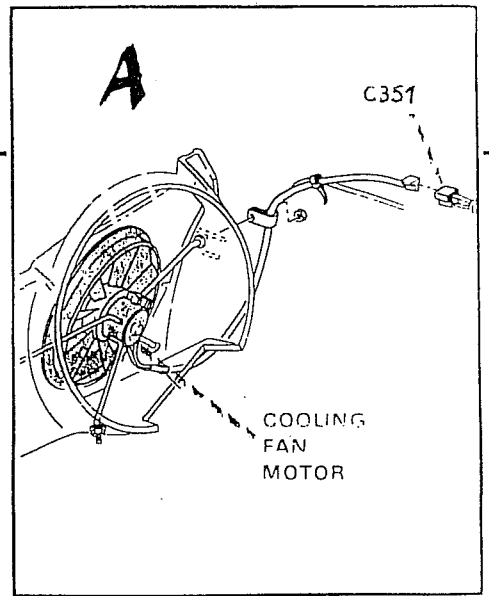

A

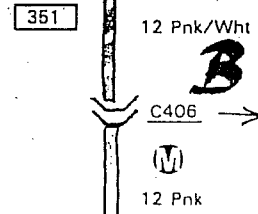

S228

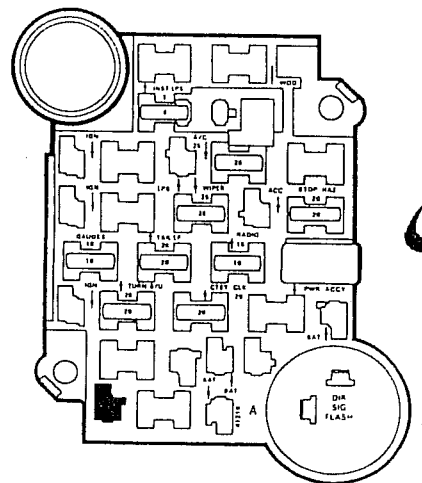
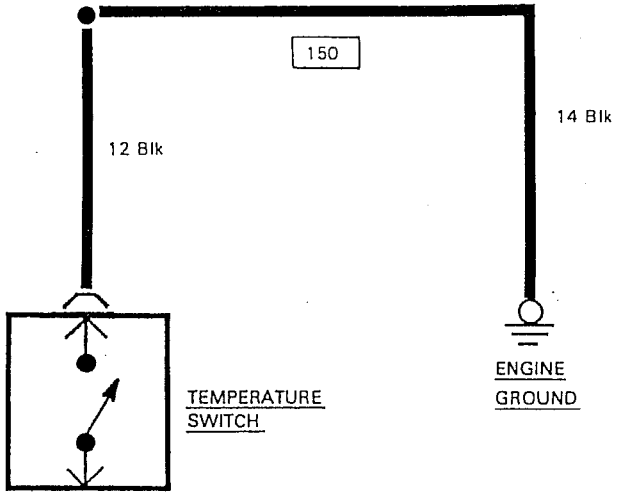
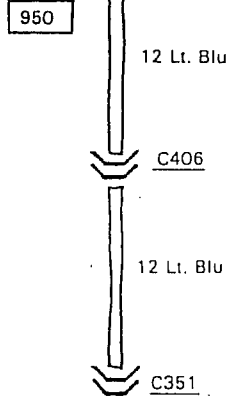
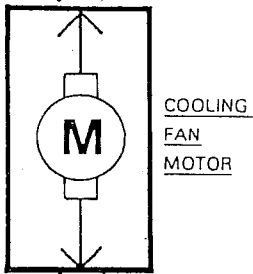

C = Sicherung

GENERAL – MOTORS - Chevy					
Corvette, Caprice, Camaro, VAN, Blazer, K5, S10, S15, Astro, usw.				Stück	Preis
001	Smallblock – Motor 4,9-5,7 L m. Nebenagregaten	Rep.-Buch	80 S.		65,--
002	Schneller machen 5,7 L Mot. BB + TH 700	Kurzbeschreibung	52 S.		55,--
003	Motorbuch 1,9 2,0 2,0D 2,5 2,8 4,3	Rep.Buch	200 S.		79,--
004	Diesel 6,2 L. mit Einspritzung	Rep.Buch	94 S.		65,--
005	Diesel 6,5 L. mit Einspritzung	Rep.Buch	90 S.		65,--
006	Diesel Wartungsinterwalle und Arbeiten am Diesel		20 S.		19,--
007	Serien Nr. Anordnung + Entschlüsselung der Motoren+Getriebe		44 S.		50,--
008	THM 250 C Automatic-Getriebe	Ausführliches Rep.-Buch	66 S.		64,--
009	TH 350/400 Automatic-Getriebe	Ausführliches Rep.-Buch	168 S.		98,--
010	TH 700 R4 Automatic-Getriebe	Ausführliches Rep.-Buch	126 S.		98,--
011	Zwischengetriebe 208 für 4 Rad-Antrieb	Rep.-Buch	42 S.		39,--
012	Hydr. Bremskraftverstärker HYDRO – BOOST	1 + 2	54 S.		48,--
013	Tempomath V 6 V 8		28 S.		24,--
014	TURBOLADER für 3,8+4,9L.Motoren Bj.78-80	Rep.-Buch	58 S.		60,--
015	Klimaanlage ab Bj.79	Rep.-Buch	74 S.		62,--
016	TBI – EINSPRITZUNG bis Bj.84	Rep.-Buch	48 S.		45,--
017	TPI - EINSPRITZUNG ab Bj.85	Rep.-Buch	42 S.		45,--
018	CORVETTE 84 – 91	kompl. Rep.-Buch	546 S.		198,--
019	VAN GM+GMC 68 – 92	kompl. Rep.-Buch	600 S.		198,--
020	CAPRICE Limos. + Kombi 79 – 89	kompl. Rep.-Buch	670 S.		198,--
GM ELEKTRO-SCHALTPLÄNE und TESTER					
021	Corvette 76 – 79 80 81	je 39,-- DM			39,--
022	Corvette 84 – 91		52 S.		50,--
023	VAN 68 – 92		40 S.		42,--
024	Caprice 80 81	je 35,--			35,--
025	Caprice 79 – 89				35,--
026	El – Camino + Monte – Carlo 64 – 75		30 S.		25,--
027	El – Camino + Monte – Carlo 76 – 88		30 S.		25,--
028	ASTRO 4,3 L. 87 – 90		62 S.		50,--
029	Blazer K5 Suburban, Pick – Up 84 – 87		54 S.		50,--
030	Blazer K5 Suburban, Pick – Up 88 – 98		30 S.		29,--
031	Blazer S – 10 / S – 15 Jimmy, Typhon, 83 – 95		64 S.		50,--
032	Monza 78 – 79 80 – 81	je 35,-- DM			35,--
033	Camaro 67 – 81 82 – 85 86 – 88 93 – 98	je 36,-- DM			36,--
034	TESTER Code – Scanner CP 9001 für alle GM – Modelle				159,--
035	Anleitung Code – Scanner CP 9001	Handbuch	46 S.		55,--
036	Anleitung Code – Scanner CP 9110	Handbuch	34 S.		40,--
037	Anleitung HE – Tester J-24542-B + J-24642-C		10 S.		10,--

Deutsche Übersetzungen US-Schmidt

TEL.02336-15995 FAX 16195 bis 23 Uhr

Internet: www.us-schmidt.de E-Mail: H.Schmidt@telebel.de