

Jeep[®]

WRANGLER

2004



TRANSMISSION

TABLE OF CONTENTS

| | | |
|------------|--|-----------|
| 1.0 | INTRODUCTION | 1 |
| 1.1 | SYSTEM COVERAGE | 1 |
| 1.2 | SIX-STEP TROUBLESHOOTING PROCEDURE | 1 |
| 2.0 | IDENTIFICATION OF SYSTEM | 1 |
| 3.0 | SYSTEM DESCRIPTION AND FUNCTIONAL OPERATION | 1 |
| 3.1 | GENERAL DESCRIPTION | 1 |
| 3.2 | FUNCTIONAL OPERATION | 1 |
| 3.2.1 | AUTOSTICK FEATURE (IF APPLICABLE) | 1 |
| 3.2.2 | TRANSMISSION OPERATION AND SHIFT SCHEDULING AT VARIOUS OIL TEMPERATURES | 2 |
| 3.3 | DIAGNOSTIC TROUBLE CODES | 3 |
| 3.3.1 | HARD CODE | 3 |
| 3.3.2 | ONE TRIP FAILURES | 3 |
| 3.3.3 | INTERMITTENT CODE | 3 |
| 3.3.4 | STARTS SINCE SET COUNTER | 3 |
| 3.3.5 | TROUBLE CODE ERASURE | 4 |
| 3.3.6 | EATX DTC EVENT DATA | 4 |
| 3.3.7 | LIST OF DIAGNOSTIC TROUBLE CODES (DETAILED DESCRIPTIONS FOLLOW LIST) | 4 |
| 3.3.8 | DTC DESCRIPTIONS | 5 |
| 3.3.9 | QUICK LEARN | 18 |
| 3.3.10 | CLUTCH VOLUMES | 18 |
| 3.3.11 | ELECTRONIC PINION FACTOR (IF APPLICABLE) | 19 |
| 3.4 | USING THE DRBIII® | 19 |
| 3.5 | DRBIII® ERROR MESSAGES | 19 |
| 3.5.1 | DRBIII® DOES NOT POWER UP (BLANK SCREEN) | 19 |
| 3.5.2 | DISPLAY IS NOT VISIBLE | 19 |
| 3.6 | TRANSMISSION SIMULATOR (MILLER TOOL # 8333) AND ELECTRONIC TRANSMISSION ADAPTER KIT (MILLER TOOL #8333-1A) | 19 |
| 4.0 | DISCLAIMERS, SAFETY, AND WARNINGS | 20 |
| 4.1 | DISCLAIMERS | 20 |
| 4.2 | SAFETY | 20 |
| 4.2.1 | TECHNICIAN SAFETY INFORMATION | 20 |
| 4.2.2 | VEHICLE PREPARATION FOR TESTING | 20 |
| 4.2.3 | SERVICING SUB-ASSEMBLIES | 20 |
| 4.2.4 | DRBIII® SAFETY INFORMATION | 20 |
| 4.3 | WARNINGS | 21 |
| 4.3.1 | VEHICLE DAMAGE WARNINGS | 21 |
| 4.3.2 | ROAD TESTING A COMPLAINT VEHICLE | 21 |
| 4.3.3 | ELECTRONIC PINION FACTOR WARNINGS (IF APPLICABLE) | 22 |
| 4.3.4 | BULLETINS AND RECALLS | 22 |
| 5.0 | REQUIRED TOOLS AND EQUIPMENT | 22 |
| 6.0 | GLOSSARY OF TERMS | 22 |
| 6.1 | ACRONYMS | 22 |
| 6.2 | DEFINITIONS | 22 |

TABLE OF CONTENTS - Continued

| | | |
|------------|---|-----------|
| 7.0 | DIAGNOSTIC INFORMATION AND PROCEDURES | 23 |
| | COMMUNICATION | |
| | *NO RESPONSE FROM TRANSMISSION CONTROL MODULE | 24 |
| | TRANSMISSION - 42RLE | |
| | P0122-THROTTLE POSITION SENSOR/APPS LOW | 27 |
| | P0123-THROTTLE POSITION SENSOR/APPS HIGH | 29 |
| | P0124- THROTTLE POSITION SENSOR/APPS INTERMITTENT..... | 31 |
| | P0218-HIGH TEMPERATURE OPERATION ACTIVATED | 33 |
| | P0562-LOW BATTERY VOLTAGE | 35 |
| | P0604-INTERNAL TCM | 38 |
| | P0605-INTERNAL TCM | 39 |
| | P0613-INTERNAL TCM | 40 |
| | P0706-CHECK SHIFTER SIGNAL..... | 41 |
| | P0711-TRANSMISSION TEMPERATURE SENSOR PERFORMANCE..... | 47 |
| | P0712-TRANSMISSION TEMPERATURE SENSOR LOW..... | 50 |
| | P0713-TRANSMISSION TEMPERATURE SENSOR HIGH | 53 |
| | P0714-TRANSMISSION TEMPERATURE SENSOR INTERMITTENT | 56 |
| | P0715-INPUT SPEED SENSOR ERROR | 58 |
| | P0720-OUTPUT SPEED SENSOR ERROR | 62 |
| | P0725-ENGINE SPEED SENSOR CIRCUIT..... | 66 |
| | P0731-GEAR RATIO ERROR IN 1ST | 69 |
| | P0732-GEAR RATIO ERROR IN 2ND..... | 71 |
| | P0733-GEAR RATIO ERROR IN 3RD..... | 74 |
| | P0734-GEAR RATIO ERROR IN 4TH..... | 77 |
| | P0736-GEAR RATIO ERROR IN REVERSE..... | 80 |
| | P0740-TORQUE CONVERTER CLUTCH CONTROL CIRCUIT..... | 82 |
| | P0750-LR SOLENOID CIRCUIT..... | 84 |
| | P0755-2/4 SOLENOID CIRCUIT | 88 |
| | P0760-OD SOLENOID CIRCUIT | 92 |
| | P0765-UD SOLENOID CIRCUIT | 96 |
| | P0841-LR PRESSURE SWITCH SENSE CIRCUIT | 100 |
| | P0845-2/4 HYDRAULIC PRESSURE TEST FAILURE | 104 |
| | P0846-2/4 PRESSURE SWITCH SENSE CIRCUIT | 108 |
| | P0870-OD HYDRAULIC PRESSURE TEST FAILURE | 112 |
| | P0871-OD PRESSURE SWITCH SENSE CIRCUIT | 116 |
| | P0884-POWER UP AT SPEED | 120 |
| | P0888-RELAY OUTPUT ALWAYS OFF | 121 |
| | P0890-SWITCHED BATTERY | 123 |
| | P0891-TRANSMISSION RELAY ALWAYS ON | 125 |
| | P0897-WORN OUT/BURNT TRANSAXLE FLUID..... | 128 |
| | P0944-LOSS OF PRIME..... | 130 |
| | P0992- 2-4/OD HYDRAULIC PRESSURE TEST FAILURE | 133 |
| | P1652-SERIAL COMMUNICATION LINK MALFUNCTION..... | 135 |
| | P1684-BATTERY WAS DISCONNECTED..... | 137 |
| | P1687-NO COMMUNICATION WITH THE MIC | 140 |
| | P1694-BUS COMMUNICATION WITH ENGINE MODULE..... | 142 |
| | P1775-SOLENOID SWITCH VALVE LATCHED IN TCC POSITION | 144 |
| | P1776-SOLENOID SWITCH VALVE LATCHED IN LR POSITION..... | 148 |
| | P1790-FAULT IMMEDIATELY AFTER SHIFT | 152 |
| | P1793-TRD LINK COMMUNICATION ERROR | 153 |
| | P1794-SPEED SENSOR GROUND ERROR | 156 |

TABLE OF CONTENTS - Continued

| | |
|---|------------|
| P1797-MANUAL SHIFT OVERHEAT | 158 |
| *BACKUP LAMPS COME ON WHILE SHIFTER IS NOT IN REVERSE POSITION. . | 160 |
| *BACKUP LAMPS INOPERATIVE | 162 |
| *CHECKING PARK/NEUTRAL SWITCH OPERATION | 165 |
| *INCORRECT TRANSMISSION FLUID LEVEL | 167 |
| *NO SPEEDOMETER OPERATION | 168 |
| *TRANSMISSION NOISY WITH NO DTC'S PRESENT | 169 |
| *TRANSMISSION SHIFTS EARLY WITH NO DTC'S | 170 |
| *TRANSMISSION SIMULATOR 8333 WILL NOT POWER UP | 171 |
| | |
| VERIFICATION TESTS | |
| VERIFICATION TESTS | 172 |
| | |
| 8.0 COMPONENT LOCATIONS | 175 |
| | |
| 8.1 POWERTRAIN CONTROL MODULE | 175 |
| 8.2 INPUT/OUTPUT SPEED SENSORS/TRS COMPONENT LOCATIONS | 175 |
| 8.3 TRANSMISSION CONTROL MODULE | 175 |
| 8.4 TRANSMISSION SOLENOID/PRESSURE SWITCH ASSEMBLY | 176 |
| | |
| 9.0 CONNECTOR PINOUTS | 177 |
| | |
| CRANKSHAFT POSITION SENSOR (2.4L/4.0L A/T) - BLACK 3 WAY | 177 |
| DATA LINK CONNECTOR - BLACK 16 WAY | 177 |
| INPUT SPEED SENSOR - 2 WAY | 177 |
| OUTPUT SPEED SENSOR - 2 WAY | 177 |
| OVERDRIVE OFF SWITCH - 4 WAY | 178 |
| TRANSMISSION CONTROL RELAY (IN PDC) | 180 |
| POWERTRAIN CONTROL MODULE C1 - BLACK 32 WAY | 180 |
| POWERTRAIN CONTROL MODULE C2 - WHITE 32 WAY | 181 |
| POWERTRAIN CONTROL MODULE C3 - GRAY 32 WAY | 182 |
| THROTTLE POSITION SENSOR (2.4L) - WHITE/BLUE 3 WAY | 182 |
| THROTTLE POSITION SENSOR (4.0L) - 3 WAY | 183 |
| TRANSFER CASE SWITCH (EXCEPT OFF-ROAD PACKAGE) - BLACK 2 WAY .. | 183 |
| TRANSFER CASE SWITCH (OFF-ROAD PACKAGE) - BLACK 2 WAY | 183 |
| TRANSMISSION CONTROL MODULE - 60 WAY | 184 |
| TRANSMISSION RANGE SENSOR - 10 WAY | 185 |
| TRANSMISSION SOLENOID/PRESSURE SWITCH ASSEMBLY - 10 WAY | 185 |
| | |
| 10.0 SCHEMATIC DIAGRAMS | 187 |
| | |
| 11.0 CHARTS AND GRAPHS | 189 |
| | |
| 11.1 PRESSURE SWITCH STATES | 189 |
| 11.2 SOLENOID APPLICATION CHART | 189 |
| 11.3 SHIFT LEVER ERROR CODES | 189 |
| 11.4 TRANSMISSION TEMPERATURE SENSOR | 190 |

1.0 INTRODUCTION

The procedures contained in this manual include all of the specifications, instructions, and graphics needed to diagnose 42RLE Electronic Automatic Transmission (EATX) problems. The diagnostics in this manual are based on the failure condition or symptom being present at the time of diagnosis.

When repairs are required, refer to the appropriate volume of the service manual for the proper removal and repair procedure.

Diagnostic procedures change every year. New diagnostic systems may be added and/or carryover systems may be enhanced. **READ THIS MANUAL BEFORE TRYING TO DIAGNOSE A VEHICLE TROUBLE CODE.** It is recommended that you review the entire manual to become familiar with all new and changed diagnostic procedures.

This book reflects many suggested changes from readers of past issues. After using this book, if you have any comments or recommendations, please fill out the form at the back of the book and mail it back to us.

1.1 SYSTEM COVERAGE

This diagnostic procedures manual covers all TJ equipped with a 42RLE Transmission.

1.2 SIX-STEP TROUBLESHOOTING PROCEDURE

Diagnosis of the 42RLE electronic Transmission is done in six basic steps:

- verification of complaint
- verification of any related symptoms
- symptom analysis
- problem isolation
- repair of isolated problem
- verification of proper operation

2.0 IDENTIFICATION OF SYSTEM

Visual identification of vehicles equipped with a 4 speed transmission, the Solenoid/Pressure Switch Assembly is located on the passenger side, The Transmission Range Sensor, Input Speed Sensor and Output Speed Sensor are located on the drivers side of the transmission. Refer to the Service Information for transmission ID tag descriptions.

3.0 SYSTEM DESCRIPTION AND FUNCTIONAL OPERATION

3.1 GENERAL DESCRIPTION

The 42RLE electronic Transmission is a conventional Transmission in that it uses hydraulically applied clutches to shift a planetary gear train. However, the electronic control system replaces many of the mechanical and hydraulic components used in conventional transmission valve bodies.

3.2 FUNCTIONAL OPERATION

The 42RLE/AE electronic Transmission has a fully adaptive control system. The system performs it's functions based on continuous real-time sensor feedback information. The control system automatically adapts to changes in engine performance and friction element variations to provide consistent shift quality. The control system ensures that clutch operation during upshifting and downshifting is more responsive without increased harshness.

The Transmission Control Module (TCM) continuously checks for electrical problems, mechanical problems, and some hydraulic problems. When a problem is sensed, the TCM stores a diagnostic trouble code. Some of these codes cause the Transmission to go into Limp-in or default mode. While in this mode, electrical power is taken away from the Transmission via the TCM, de-energizing the transmission control relay, and taking power from the solenoid pack. When this happens, the only Transmission mechanical functions are:

- Park and Neutral
- Reverse
- Second Gear

No upshifts or downshifts are possible. The position of the manual valve alone allows the three ranges that are available. Although vehicle performance is seriously degraded while in this mode, it allows the owner to drive the vehicle in for service.

Once the DRBIII® is in the EATX portion of the diagnostic program, it constantly monitors the TCM to see if the system is in Limp-in mode. If the Transmission is in Limp-in mode, the DRBIII® will flash the red LED.

3.2.1 AUTOSTICK FEATURE (IF APPLICABLE)

This feature allows the driver to manually shift the Transmission when the shift lever is pulled into the AutoStick position. When in AutoStick mode, the instrument cluster displays the current gear.

GENERAL INFORMATION

3.2.2 TRANSMISSION OPERATION AND SHIFT SCHEDULING AT VARIOUS OIL TEMPERATURES

The transmission covered in this manual has unique shift schedules depending on the temperature of the transmission oil. The shift schedule is modified to extend the life of the transmission while operating under extreme conditions.

The oil temperature is measured with a Temperature Sensor on the 42RLE/AE transmission. The Temperature Sensor is an integral component of the Transmission Range Sensor (TRS). If the Temperature Sensor is faulty, the transmission will default to a calculated oil temperature. Oil temperature will then be calculated through a complex heat transfer equation using engine coolant temperature, battery/ambient temperature, and engine off time from the Body Control Module (BCM). These inputs are received from the PCI bus periodically and used to initialize the oil temperature at start up. Once the engine is started, the TCM updates the transmission oil temperature based on torque converter slip speed, vehicle speed, gear, and engine coolant temperature to determine an estimated oil temperature during vehicle operation. Vehicles using calculated oil temperature track oil temperature reasonably accurate during normal operation. However, if a transmission is overfilled, a transmission oil cooler becomes restricted, or if a customer drives aggressively in low gear, the calculated oil temperature will be inaccurate. Consequently the shift schedule selected may be inappropriate for the current conditions. The key highlights of the various shift schedules are as follows:

Extreme Cold: Oil temperature at start up below 26.6°C (-16°F)

- > Goes to Cold schedule above -24°C (-12°F) oil temperature
- > Park, Reverse, Neutral and 2nd gear only (prevents shifting which may fail a clutch with frequent shifts)

Cold: Oil temperature at start up above -24°C (-12°F) and below 2.2°C (36°F)

- > Goes to Warm schedule above 4.4°C (40°F) oil temperature
- > Delayed 2-3 upshift approximately 35-50 Km/h (22 - 31 MPH)
- > Delayed 3-4 upshift 72-85 Km/h (45-53 MPH)
- > Early 4-3 coastdown shift approximately 48 Km/h (30 MPH)
- > Early 3-2 coastdown shift approximately 27 Km/h (17 MPH)
- > High speed 4-2, 3-2, 2-1 kickdown shifts are prevented

- > No EMCC

Warm: Oil temperature at start up above 2.2°C (36°F) and below 27°C (80°F)

- > Goes to a Hot schedule above 27°C (80°F) oil temperature
- > Normal operation (upshifts, kickdowns, and coastdowns)
- > No EMCC

Hot: Oil temperature at start up above 27°C (80°F)

- > Goes to a Overheat schedule above 115°C (240°F) oil temperature
- > Normal operation (upshifts, kickdowns, and coastdowns)
- > Full EMCC, No PEMCC except to engage FEMCC, except at closed throttle at speeds above 113-133 Km/h (70 - 83 MPH)

Overheat: Oil temperature above 115°C (240°F) or engine coolant temperature above 118°C (244°F)

- > Goes to a Hot below 110°C (230°F) oil temperature or a Super Overheat above 115°C (240°F) oil temperature
- > Delayed 2-3 upshift 40-51 Km/h (25-32 MPH)
- > Delayed 3-4 upshift 66-77 Km/h (41-48 MPH)
- > 3rd gear FEMCC from 48-77 Km/h (30-48 MPH)
- > 3rd gear PEMCC from 43-50 Km/h (27-31 MPH)

Super Overheat: Oil temperature above 127°C (260°F)

- > Goes back to a Overheat below 115°C (240°F) oil temperature
- > All a Overheat shift schedules features apply
- > 2nd gear PEMCC above 35 Km/h (22 MPH)
- > Above 35 Km/h (22 MPH) the torque converter will not unlock unless the throttle is closed (i.e. at 80 Km/h (50 MPH) a 4th FEMCC to 3rd FEMCC shift will be made during a part throttle kickdown or a 4th FEMCC to 2nd PEMCC shift will be made at wide open throttle) or if a wide open throttle 2nd PEMCC to 1 kickdown is made.

Causes for operation in the wrong temperature shift schedule:

Extreme Cold or Cold shift schedule at start up:

- > Temperature Sensor circuit.
- > Overheat or Super Overheat shift schedule after extended operation:
- > Operation in city traffic or stop and go traffic
- > Engine idle speed too high
- > Aggressive driving in low gear
- > Trailer towing in OD gear position (use 3 position (or A/S 3rd) if frequent shifting occurs)
- > Cooling system failure causing engine to operate over 110°C (230°F)

- > Engine coolant temperature stays low too long
 - If engine coolant temperature drops below 65°C (150°F), the transmission will disengage EMCC. Extended operation with the EMCC disengaged will cause the transmission to overheat.
- > Brake switch issue will cause the EMCC to disengage. Extended operation with the EMCC disengaged will cause the transmission to overheat.
- > Transmission fluid overfilled
- > Transmission cooler or cooler lines restricted
- > Transmission Temperature Sensor circuit

3.3 DIAGNOSTIC TROUBLE CODES

Diagnostic trouble codes (DTC's) are codes stored by the Transmission Control Module (TCM) that help us diagnose Transmission problems. They are viewed using the DRBIII® scan tool.

Always begin by performing a visual inspection of the wiring, connectors, cooler lines and the transmission. Any obvious wiring problems or leaks should be repaired prior to performing any diagnostic test procedures. Some engine driveability problems can be misinterpreted as a transmission problem. Ensure that the engine is running properly and that no PCM DTC's are present that could cause a transmission complaint.

If there is a communication bus problem, trouble codes will not be accessible until the problem is fixed. The DRBIII® will display an appropriate message. The following is a possible list of causes for a bus problem:

- open or short to ground/battery in PCI bus circuit.
- internal failure of any module or component on the bus

Each diagnostic trouble code is diagnosed by following a specific testing sequence. The diagnostic test procedures contain step-by-step instructions for determining the cause of a transmission diagnostic trouble code. Possible sources of the code are checked and eliminated one by one. It is not necessary to perform all of the tests in this book to diagnose an individual code. These tests are based on the problem being present at the time that the test is run.

All testing should be done with a fully charged battery.

If the TCM records a DTC that will adversely affect vehicle emissions, it will request (via the communication bus) that the PCM illuminate the Malfunction Indicator Lamp (MIL). Although these DTC's will be stored in the TCM immediately as a 1 trip failure, it may take up to five minutes of

accumulated trouble confirmation to set the DTC and illuminate the MIL. Three consecutive successful OBDII (EURO STAGE III OBD) trips or clearing the DTC's with a diagnostic tool (DRBIII® or equivalent) is required to extinguish the MIL. When the TCM requests that the PCM illuminate the MIL, the PCM sets a DTC P0700 (\$89) to alert the technician that there are DTC's in the TCM. This must also be erased in the PCM in order to extinguish the MIL.

3.3.1 HARD CODE

Any Diagnostic Trouble Code (DTC) that is set whenever the system or component is monitored is a HARD code. This means that the problem is there every time the TCM checks that system or component. Some codes will set immediately at start up and others will require a road test under specific conditions. It must be determined if a code is repeatable (Hard) or intermittent before attempting diagnosis.

3.3.2 ONE TRIP FAILURES

A One Trip Failure, when read from the TCM, is a hard OBDII (EURO STAGE III OBD) code that has not matured for the full 5 minutes. This applies to codes that will only set after 5 minutes of substituted gear operation.

3.3.3 INTERMITTENT CODE

A diagnostic trouble code that is not there every time the TCM checks the circuit or function is an intermittent code. Some intermittent codes, such as codes P1684(12), P0891(14), P0888(15), P0725(18), P1694(19), P0871(21), P0846(22), P1724(24), P0706(28), P0120(29), P0750(41), P0755(42), P0760(43), P0765(44), P1793(48), P0715(56), P0720(57), P1794(58), P0951(70), P1799(74), P0884(76), P1687(77), and P1652(78) are caused by wiring or connector problems. However intermittent codes 50 - 54 are usually caused by intermittent hydraulic seal leakage in the clutch and/or accumulator circuits. Problems that come and go like this are the most difficult to diagnose, they must be looked for under the specific conditions that cause them.

3.3.4 STARTS SINCE SET COUNTER

For the most recent code, the Starts Since Set counter counts the number of times the vehicle has started since it was last set. The counter will count up to 255 starts. Note that this code only applies to the last or most recent code set.

When there are no diagnostic trouble codes stored in memory, the DRBIII® will display NO DTC's PRESENT and the reset counter will show "STARTS SINCE CLEAR = XXX"

GENERAL INFORMATION

The number of starts helps determine if the diagnostic trouble code is hard or intermittent.

- If the count is less than 3, the code is usually a hard code.
- If the count is greater than 3, it is considered an intermittent code. This means that the engine has been started most of the time without the code recurring.

3.3.5 TROUBLE CODE ERASURE

A Diagnostic trouble code will be cleared from TCM memory if it has not reset for 40 warm-up cycles.

A warm-up cycle is defined as sufficient vehicle operation such that the coolant temperature has risen by at least 22°C (40°F) from engine starting and reaches a minimum temperature of 71°C (160°F).

The Malfunction Indicator Lamp (MIL) will turn off after 3 good trips or when the DTC's are cleared from the TCM.

3.3.6 EATX DTC EVENT DATA

EATX DTC EVENT DATA can be used as a diagnostic aid when experiencing Electronic Transmissions with intermittent problems. When a Diagnostic Trouble Code (DTC) is set, the vehicles EATX inputs are stored in the controller memory and are retrievable with the DRBIII®. This information can

be helpful when a DTC can not be duplicated.

The EATX DTC EVENT DATA is located in the DRBIII®, under the Transmission system menu, in the sub-screen Miscellaneous. It is a good practice to document the EATX DTC EVENT DATA before beginning any diagnostic or service procedure.

A thorough understanding of how the transmission works is beneficial in order to interpret the data correctly. These skills are necessary in order to avoid an incorrect diagnosis.

A MASTERTech video and reference book was produced in January 2002 that explains many of the features of the EATX DTC EVENT DATA with several examples on how to interpret the information and suggested training material to help understand all the specifics.

EATX DTC EVENT DATA can only be erased by:

1. Disconnecting the battery.
2. Performing a DRBIII® QUICK LEARN procedure.
3. Reprogramming the EATX controller.

Erasing Transmission DTCs does not clear the EATX DTC EVENT DATA.

3.3.7 LIST OF DIAGNOSTIC TROUBLE CODES (DETAILED DESCRIPTIONS FOLLOW LIST)

| The TCM may report any of the following DTC's. | | | | |
|--|--------|--|---------|-------|
| DTC | P-Code | Name of Code | Limp-in | MIL |
| 11 | P0613 | Internal TCM | Yes | Yes |
| 12 | P1684 | Battery was disconnected | No | No |
| 13 | P0613 | Internal TCM | Yes | Yes |
| 14 | P0891 | Transmission Relay always on | Yes | Yes |
| 15 | P0888 | Relay output always off | Yes | Yes |
| 16 | P0605 | Internal TCM | Yes | Yes |
| 17 | P0604 | Internal TCM | Yes | Yes |
| 18 | P0725 | Engine speed sensor circuit | Yes | Yes |
| 19 | P1694 | Bus communication with engine module | No | No |
| 20 | P0890 | Switched battery | Yes | Yes |
| 21 | P0871 | OD pressure switch sense circuit | Yes | Yes-1 |
| 22 | P0846 | 2/4 pressure switch sense circuit | Yes | Yes |
| 24 | P0841 | LR pressure switch sense circuit | Yes | Yes |
| 28 | P0706 | Check shifter signal | No | No |
| 29 | P0124 | Throttle Position Sensor/APPS intermittent | No | Yes-3 |
| 2A | P0122 | Throttle Position Sensor /APPS low | No | Yes-3 |
| 2B | P0123 | Throttle Position Sensor /APPS high | No | Yes-3 |
| 31 | P0870 | OD hydraulic pressure test failure | Yes | Yes |
| 32 | P0845 | 2/4 hydraulic pressure test failure | Yes | Yes |
| 33 | P0992 | 2-4/OD hydraulic pressure test failure | Yes | Yes |
| 35 | P0944 | Loss of prime | No | No |

The TCM may report any of the following DTC's.

| DTC | P-Code | Name of Code | Limp-in | MIL |
|-----|--------|---|---------|--------------|
| 36 | P1790 | Fault immediately after shift | No | No |
| 37 | P1775 | Solenoid switch valve latched in TCC position | No | <u>Yes</u> |
| 38 | P0740 | Torque converter clutch control circuit | No | <u>Yes</u> |
| 41 | P0750 | LR Solenoid circuit | Yes | Yes |
| 42 | P0755 | 2/4 Solenoid circuit | Yes | Yes |
| 43 | P0760 | OD Solenoid circuit | Yes | Yes |
| 44 | P0765 | UD Solenoid circuit | Yes | Yes |
| 45 | P0613 | Internal TCM | No | No |
| 47 | P1776 | Solenoid switch valve latched in LR position | Yes | Yes |
| 48 | P1793 | TRD link communication error | No | <u>Yes-4</u> |
| 50 | P0736 | Gear ratio error in reverse | Yes | <u>Yes</u> |
| 51 | P0731 | Gear ratio error in 1st | Yes | <u>Yes</u> |
| 52 | P0732 | Gear ratio error in 2nd | Yes | <u>Yes</u> |
| 53 | P0733 | Gear ratio error in 3rd | Yes | <u>Yes</u> |
| 54 | P0734 | Gear ratio error in 4th | Yes | <u>Yes</u> |
| 56 | P0715 | Input speed sensor error | Yes | <u>Yes</u> |
| 57 | P0720 | Output speed sensor error | Yes | <u>Yes</u> |
| 58 | P1794 | Speed sensor ground error | Yes | <u>Yes</u> |
| 71 | P1797 | Manual shift overheat | No | No |
| 73 | P0897 | Worn out/burnt Transmission fluid | No | No |
| 75 | P0218 | High temperature operation activated | No | No |
| 7A | P0711 | Transmission temperature sensor performance | No | No |
| 7B | P0712 | Transmission temperature sensor low | No | No |
| 7C | P0713 | Transmission temperature sensor high | No | No |
| 7D | P0714 | Transmission temperature sensor intermittent | No | No |
| 76 | P0884 | Power up at speed | No | No |
| 77 | P1687 | No communication with the MIC | No | No |
| 78 | P1652 | Serial communication link malfunction | No | No-2 |
| 79 | P0562 | Low battery voltage | Yes | <u>Yes</u> |

Notes:

P1xxx DTC's will set the MIL only after 10 seconds of vehicle operation.

- 1 - The Mil will be lit only if DTC P0706 is also present
- 2 - The MIL will be lit by the engine controller
- 3 - The MIL will be lit only if the engine controller is not calibrated for throttle substitution.
- 4 - The MIL will be lit for engines that limit throttle after a TRD problem.

Yes (underlined) indicates that this DTC can take up to five minutes of problem identification before illuminating the MIL.

3.3.8 DTC DESCRIPTIONS

Name of code: P0613 (11, 13, or 45) - Internal Controller

When monitored: Whenever the key is in the Run or Run/Start position.

Set condition: This code is set whenever Transmission Control Module (TCM) senses an internal error.

Theory of operation: The TCM is constantly monitoring it's internal processor. If an internal problem is detected, this DTC will be set. This DTC can also be set by a bad ground to the TCM and/or Trans Control Relay.

Transmission Effects: The MIL will illuminate (this DTC can take up to five minutes of problem identification before illuminating the MIL) and the transmission system will default to the Immediate Shutdown routine.

Possible causes:

- > TCM ground circuit.
- > Relay ground circuit.
- > TCM

Name of code: P1684(12) - Battery was Disconnected (Informational code Only)

When monitored: Whenever the key is in the Run/Start position.

GENERAL INFORMATION

Set condition: This code is set whenever the Transmission Control Module (TCM) is disconnected from battery power (B+) or ground. It will also be set during the DRBIII® Battery Disconnect procedure.

Theory of operation: A battery backed RAM (Random Access Memory) is used to maintain some learned values. When the battery B(+) is disconnected, the memory is lost. When the B(+) is restored, this memory loss is detected by the TCM. The code is set and the learned values are initialized to known constants or previously learned values from EEPROM (Electronic Erasable Programmable Read Only Memory). This results in the initialization of some parameters.

Transmission Effects: Loss of trouble code data. Immediate Limp-in mode if power is lost while operating the vehicle. Normal operation is resumed if the power is restored during the same key start.

Possible causes:

- > Battery voltage removed from TCM
- > TCM disconnected
- > Dead Battery
- > Low battery voltage during cranking
- > Battery Disconnect by DRBIII® or MDS
- > Bad TCM ground circuit.

Name of code: P0891(14) - Transmission Relay Always On

When monitored: Ignition key is turned from off position to run position and/or ignition key is turned from crank position to run position.

Set condition: This code is set if the Transmission Control Module (TCM) senses greater than 3 volts at the Trans Relay Output (switched battery) terminal of the TCM prior to the TCM energizing the relay.

Theory of operation: The transmission control relay is used to supply power to the solenoid pack when the transmission is in normal operating mode. When the relay is off, no power is supplied to the solenoid pack and the transmission is in Limp-in mode. The relay output is fed back to the TCM through pins 16 and 17. It is referred to as the Trans Relay Output circuit or switched battery.

Transmission Effects: The MIL will illuminate and the transmission system defaults to Logical Limp-in mode. Logical Limp-in mode results in the same modes of operation as Limp-in. Since the relay is stuck "on", the TCM can not open the relay, and the TCM shifts to 2nd gear.

Possible causes:

- > Relay (welded contacts)
- > Short to battery in 12-volt supply and/or Transmission Control Relay Output circuit(s)
- > Short to voltage

> TCM connector problems

> TCM

Name of code: P0888(15) - Relay Output Always Off

When monitored: Continuously

Set condition: This code is set when less than 3 volts are present at the Trans Relay Output (switched battery) terminals at the Transmission Control Module (TCM) when the TCM is energizing the relay.

Theory of operation: The transmission control relay is used to supply power to the solenoid pack when the transmission is in normal operating mode. When the relay is off, no power is supplied to the solenoid pack and the transmission is in Limp-in mode. The relay output is fed back to the TCM through pins 16 and 17. It is referred to as the Trans Relay Output circuit or switched battery.

After a controller reset (ignition key turned to the run position or after cranking engine), the controller energizes the relay. Prior to this the TCM verifies that the contacts are open by checking for no voltage at the switched battery terminals. After the relay is energized, the TCM monitors the terminals to verify that the voltage is greater than 3 volts.

Transmission Effects: The MIL illuminates and the transmission system defaults to Limp-in mode.

Possible causes:

- > Relay failure (intermittent relay function caused by oxidized or contaminated relay contacts)
- > Short to ground or open circuit in the Transmission Control Relay circuit(s)
- > TCM connector problem
- > TCM

Name of code: P0725(18) - Engine Speed Sensor Circuit

NOTE: This code is not a Transmission Input Speed Sensor DTC

When monitored: Whenever the engine is running.

Set condition: This code is set when the engine speed sensed by the Transmission Control Module (TCM) is less than 390 RPM or greater than 8000 RPM for more than 2.0 seconds.

Theory of operation: The TCM uses either a EATX RPM signal (simulated Crank Sensor signal) or the TCM uses the Crank Position Sensor signal to calculate engine RPM depending on the engine application. The signal supplied by the PCM and uses a dedicated circuit is called the EATX RPM Signal circuit. The Crank Position Sensor signal is a spliced circuit from the engine Crank Position Sensor. Check the wiring schematics to determine

which (engine speed sensor circuit) is used in the vehicle. If the TCM interprets this signal to be out of range when the engine is running (as reported by the PCM over the bus) the code is set.

Transmission Effects: The MIL illuminates and the transmission system defaults to Limp-in mode.

Possible causes:

- > Open or short in EATX RPM Signal circuit.
- > Open or short in Crank Position Sensor Signal circuit.
- > Open or short in Crank Position Sensor ground circuit.
- > TCM and/or PCM connector problems
- > TCM
- > PCM

Name of code: P1694(19) - Bus Communication with Engine Module

When monitored: Continuously with key on.

Set condition: If no PCI bus messages are received from the Powertrain Control Module (PCM) for 10 seconds. **Theory of operation:** The TCM communicates with the PCM using the PCI bus. It relies on certain information to function properly. The TCM continuously monitors the PCI bus to check for messages broadcast from the PCM.

Transmission Effects: Delayed 3-4 shifts. No EMCC and early 3-4 shifts for a few minutes after engine is started.

Possible causes:

- > Open or shorted PCI bus circuit
- > TCM
- > PCM

Name of code: P0890(20) - Switched Battery

When monitored: Ignition key is turned from off position to run position and/or ignition key is turned from crank position to run position.

Set condition: This code is set if the Transmission Control Module (TCM) senses voltage on any of the pressure switch inputs prior to the TCM energizing the relay.

Theory of operation: The transmission control relay is used to supply power to the solenoid pack when the transmission is in normal operating mode. When the relay is off, no power is supplied to the solenoid pack and the transmission is in Limp-in mode. The relay output is fed back to the TCM through pins 16 and 17. It is referred to as the Trans Relay Output circuit or a switched battery.

Immediately after a controller reset (ignition key turned to the run position or after cranking engine), the TCM verifies that the relay contacts are open by checking for no voltage at the switched battery terminals. After this is verified, the voltage at the Solenoid Pack pressure switches is checked.

There should be no voltage on the pressure switches at this time. The TCM will then activate the relay.

Transmission Effects: The MIL illuminates and the transmission system defaults to Limp-in mode.

Possible causes:

- > Short to battery on one or more pressure switch sense circuits
- > TCM connector problems
- > TCM

Name of code: P0871(21) - OD Pressure Switch Sense Circuit

When monitored: Whenever the engine is running.

Set condition: This code is set if the OD pressure switch is open or closed at the wrong time in a given gear (see chart below).

Theory of operation: The Transmission system uses three pressure switches to monitor the fluid pressure in the LR, 2/4, and OD clutch circuits. The pressure switches are continuously monitored for the correct states in each gear as shown below.

PRESSURE SWITCH STATES

| SWITCHES | R | N | 1ST | 2ND | 3RD | 4TH |
|----------|------|--------|--------|--------|--------|--------|
| L/R | OPEN | CLOSED | CLOSED | OPEN | OPEN | OPEN |
| 2/4 | OPEN | OPEN | OPEN | CLOSED | OPEN | CLOSED |
| O/D | OPEN | OPEN | OPEN | OPEN | CLOSED | CLOSED |

80d9d3b5

Transmission Effects: Normal operation will be experienced if no other codes are present. TCM will ignore the code. Limp-in condition will only occur if code P0871(21) is present with a code P0706(28).

Possible causes:

- > If code P0944(35) is present, ignore code P0871(21) and perform code P0944 diagnostic procedures
- > OD pressure switch sense circuit open or shorted to ground between TCM and solenoid pack
- > OD pressure switch sense circuit shorted to battery
- > Solenoid pack
- > Loose valve body bolts
- > Plugged filter - internal transmission or torque converter failure
- > TCM

GENERAL INFORMATION

Name of code: P0846(22) - 2/4 Pressure Switch Sense Circuit

When monitored: Whenever the engine is running.

Set condition: This code is set if the 2/4 pressure switch is open or closed at the wrong time in a given gear (see chart below).

Theory of operation: The Transmission system uses three pressure switches to monitor the fluid pressure in the LR, 2/4, and OD elements. The pressure switches are continuously monitored for the correct states in each gear as shown below.

PRESSURE SWITCH STATES

| SWITCHES | R | N | 1ST | 2ND | 3RD | 4TH |
|----------|------|--------|--------|--------|--------|--------|
| L/R | OPEN | CLOSED | CLOSED | OPEN | OPEN | OPEN |
| 2/4 | OPEN | OPEN | OPEN | CLOSED | OPEN | CLOSED |
| O/D | OPEN | OPEN | OPEN | OPEN | CLOSED | CLOSED |

80d9d3b5

Transmission Effects: If the 2/4 pressure switch is identified as closed in P or N, the code will immediately be set and normal operation will be allowed for that given key start. If the problem is identified for 3 successive key starts, the transmission will go into Limp-in mode.

If the 2/4 pressure switch is identified as being closed in 1st or 3rd gear and was not identified as being closed in P or N, then 2nd gear or 4th gear will be substituted for 1st or 3rd gear depending on throttle angle and vehicle speed. A short period of time after the gear substitution, the transmission will return to normal operating mode. If the transmission is shifted back into 1st or 3rd gear through normal operation, and the 2/4 pressure switch remains closed, 2nd or 4th gear will be substituted briefly and then resume normal operation. If four gear substitutions occur in a given key start, the transmission will go into Limp-in mode.

If the 2/4 pressure switch is open (indicating no 2/4 clutch pressure) in 2nd or 4th gear, the TCM sets code P0846(22) and continues with normal operation. The transmission will only go into Limp-in mode if a code P0706(28) is also present. If no 2/4 clutch pressure is present a gear ratio code P0732(52) or P0734(54) will be set and cause the limp-in condition.

Possible causes:

- > If code P0944(35) is present, ignore code P0846(22) and perform code P0944 diagnostic procedures
- > 2/4 pressure switch sense circuit open or shorted to ground between TCM and solenoid pack

- > 2/4 pressure switch sense circuit shorted to battery
- > Solenoid pack
- > Transmission overheated - Excessive regulator valve leakage in valve body causing high line pressure which results in 2/4 solenoid blow-off in 1st or 3rd gear. May require new valve body if it happens only when hot.
- > Loose valve body bolts
- > Plugged filter - internal transmission or torque converter failure
- > TCM

Name of code: P0841(24) - LR Pressure Switch Sense Circuit

When monitored: Whenever the engine is running.

Set condition: This code is set if the LR pressure switch is either open or closed at the wrong time in a given gear.

Theory of operation: The Transmission system uses three pressure switches to monitor the fluid pressure in the LR, 2/4, and OD elements. The pressure switches are continuously monitored for the correct states in each gear as shown below.

PRESSURE SWITCH STATES

| SWITCHES | R | N | 1ST | 2ND | 3RD | 4TH |
|----------|------|--------|--------|--------|--------|--------|
| L/R | OPEN | CLOSED | CLOSED | OPEN | OPEN | OPEN |
| 2/4 | OPEN | OPEN | OPEN | CLOSED | OPEN | CLOSED |
| O/D | OPEN | OPEN | OPEN | OPEN | CLOSED | CLOSED |

80d9d3b5

Transmission Effects: If a set condition is identified, 1st gear and torque converter lock-up (EMCC) will be inhibited. The vehicle will launch in 2nd gear and shift normally through the gears without allowing EMCC. If during the same key start, the set condition is no longer valid, the transmission will return to normal operation (1st and EMCC available). Limp-in will not occur unless code P0841(24) is accompanied by a code P0706(28) and the MIL will illuminate after 5 minutes of substituted operation.

Possible causes:

- > If code P0944(35) is present, ignore code P0841(24) and perform code P0944(35) diagnostic procedures
- > LR pressure switch sense circuit open or shorted to ground between TCM and solenoid pack
- > LR pressure switch sense circuit shorted to battery

- > Solenoid pack
- > Valve body - solenoid switch valve stuck in LU position. May be accompanied by a code P1775(37)
- > Loose valve body bolts
- > Plugged filter - internal transmission or torque converter failure
- > TCM

Name of code: P0706(28) - Check Shifter Signal
When Monitored: Continuously with the key on.
Set Condition: 3 occurrences in one key start of an invalid PRNDL code which lasts for more than 0.1 second.

Theory of Operation: The C1 through C4 (T1, T3, T41, and T42) sense circuits communicate the shift lever position to the TCM. Each circuit is terminated at the transmission with a switch. Each switch can be either open or closed, depending on the shift lever position. The TCM can decode this information and determine the shift lever position. Each shift lever position has a certain combination of switches which will be open and closed, this is called a PRNDL code. There are 4 switches, therefore: there are many possible combinations of open and closed switches (codes). However, there are only 9 valid codes (8 for AutoStick), one for each gear position and three recognized between gear codes. The remainder of the codes should never occur, these are called invalid codes. The following chart shows the normal switch states for each shift lever position.

| TRS | Park | T1 | Rev | T2 | N | T2 | OD | T3 | 3/AS | T3 | L |
|----------|------|----|-----|----|----|----|----|----|------|----|----|
| T1 (C4) | OP | OP | OP | CL | CL | CL | CL | CL | OP | CL | CL |
| T3 (C3) | CL | CL | OP | OP | OP | OP | OP | CL | CL | CL | CL |
| T41 (C1) | CL | OP | OP | OP | CL | OP | OP | OP | OP | OP | OP |
| T42 (C2) | CL | CL | CL | CL | CL | CL | OP | OP | OP | OP | CL |

The following are DRBIII® reported Shift Lever Error Codes (chart)

SHIFT LEVER ERROR CODES
 REPORTED BY THE DRBIII®

| ERROR CODE | SWITCH STUCK | POSITION |
|------------|--------------|----------|
| 1 | T1/C4 STUCK | OPEN |
| 2 | T1/C4 STUCK | CLOSED |
| 3 | T3/C3 STUCK | OPEN |
| 4 | T3/C3 STUCK | CLOSED |
| 5 | T42/C2 STUCK | OPEN |
| 6 | T24/C2 STUCK | CLOSED |
| 7 | T41/C1 STUCK | OPEN |
| 8 | T41/C1 STUCK | CLOSED |

Transmission Effects and possible causes:
Scenario 1) - All PRNDL lights stay illuminated indefinitely in Park following a Key start.

- > Wrong Part Number TCM for application
- > TRS connector not plugged in
- > C1 through C4 (T1, T3, T41, or T42) circuits are open, shorted to ground, or shorted to 12 volts.
- > PCI bus failure (Open or shorted resulting in no communication to BCM or Cluster)
- > TRS
- > TCM
- > BCM

Scenario 2) - “P” is indicated following a key start but all PRNDL lights illuminate in “N” following a shift from “R” to “N”. If PRNDL lights illuminate in “N” and shifter is moved directly into “3” or “L” position without pausing in “OD”, then the “OD” position shift schedule and electronic display will indicate “OD” until the shifter is shifted into the “OD” position and held for at least 3 seconds.

- > Worn Manual Lever (Rooster Comb). Check for heavy wearing by TRS switch contacts
- > Intermittent C1 through C4 (T1, T3, T41 or T42) circuits. Check for corrosion, terminal push-outs or spread terminals at 60-way and/or TRS switch 10-way connector
- > TRS
- > TCM
- > BCM

Scenario 3) - If an invalid code happens while operating in the “3” or “L” position, the “3” or “L” shift schedule and electronic display will be frozen (regardless of whether “OD”, “3” or “L” is selected). The display will be frozen until the shifter is moved to the “N” position (all PRNDL lights will illuminate) and then back to the “OD” position. The “N” and “OD” position must be held for at least 3 seconds in each position to resume the normal “OD” shift schedule and electronic display.

- > Intermittent C1 through C4 (T1, T3, T41 or T42) circuits. Check for corrosion, terminal push-outs or spread terminals at 60-way and/or TRS connector
- > TRS
- > TCM
- > BCM

These same symptoms may occur without the code P0706(28) getting set. It is possible that the invalid code that was sensed by the TCM only occurred once or twice during the given ignition key start and/or did not last for longer than 0.1 second.

GENERAL INFORMATION

Name of code: P0124(29) - Throttle Position Sensor/APPS Intermittent

Name of code: P0122(2A) - Throttle Position Sensor /APPS Low

Name of code: P0123(2B) - Throttle Position Sensor /APPS High

When monitored: Whenever the key is on or the engine is running. Engine speed > 500 rpm

Set condition:

P0124 - Throttle angle change > 5° in 7 milliseconds the Fault set time milliseconds 0.448 seconds

P0122 - Throttle angle < 6° the Fault Set Time: 0.448 seconds

P0123 - Throttle angle > 120.6° the Fault Set Time: 0.448 seconds

Theory of operation: The transmission controller receives the throttle position signal and its ground from the Throttle Position Sensor (TPS). The TPS has a 5 volt pull up supplied by the engine controller. The throttle signal is checked for out-of-range as well as intermittent operation (excessive signal changes). The engine controller transmits the throttle value via the Bus. Most engine controllers can synthesize the throttle value if the throttle position sensor signal is lost. If a throttle error is detected by the transmission controller and the throttle value is available via the Bus, the Bus throttle value will be used and normal operation will continue, however a throttle fault code will be set. If a throttle error is detected and the throttle value is not available via the Bus, normal operation will be discontinued, a throttle fault code will be set, and the MIL will be turned on after 5 min. of substituted operation.

Transmission Effects:

- If throttle value is available via the Bus -No effect.
- If throttle value is not available via the Bus
A default throttle value is used.
Torque converter lock-up inhibited.
4th gear inhibited.
Limited shift schedule.
MIL on after 5 min. of substituted operation.

Possible causes:

- > Open or shorted TPS signal and/or ground circuits
- > TCM connector problems
- > TPS or TPS connector (Check PCM DTC's)
- > PCM
- > TCM

Name of code: P0870(31) - OD Hydraulic Pressure Test Failure

P0845(32) - 2/4 Hydraulic Pressure Test Failure

P0992(33) - 2-4/OD Hydraulic Pressure Test Failure

When monitored: In 1st, 2nd, or 3rd gear with engine speed above 1000 RPM shortly after a shift and every minute thereafter.

Set condition: Immediately after a shift into 1st, 2nd, or 3rd gear, with engine speed above 1000 RPM, the TCM momentarily turns on element pressure to the 2/4 and/or OD clutch circuits to identify that the appropriate pressure switch closes. If the pressure switch does not close it is tested again. If the switch does not close the second time, the appropriate code is set.

Theory of operation: The Transmission Control Module (TCM) tests the OD and 2/4 pressure switches when they are off (OD and 2/4 are tested in 1st gear, OD in 2nd gear, and 2/4 in 3rd gear). The test verifies that the switches are operational. The TCM verifies that the switch closes when the corresponding element is applied. If a switch fails to close, it is retested, If it fails the second test, the code is set.

Transmission Effects: The MIL illuminates and the transmission system defaults to Limp-in mode.

Possible causes:

- > Pressure switch sense circuit shorted to battery between TCM and solenoid pack.
- > Low line pressure
- > Solenoid Pack

PRESSURE SWITCH STATES

| SWITCHES | R | N | 1ST | 2ND | 3RD | 4TH |
|----------|------|--------|--------|--------|--------|--------|
| L/R | OPEN | CLOSED | CLOSED | OPEN | OPEN | OPEN |
| 2/4 | OPEN | OPEN | OPEN | CLOSED | OPEN | CLOSED |
| O/D | OPEN | OPEN | OPEN | OPEN | CLOSED | CLOSED |

80d9d3b5

Name of code: Name of code: P0944(35) - Loss Of Prime

When monitored: If the transmission is slipping in any forward gear and the pressure switches are not indicating pressure, a loss of prime test is run.

Set condition: If the transmission begins to slip in any forward gear, and the pressure switch or switches that should be closed for a given gear are open, a loss of prime test begins. All available elements (in 1st gear LR, 2/4 and OD, in 2nd, 3rd, and 4th gear 2/4 and OD) are turned on by the Transmission Control Module (TCM) to see if pump prime exists. The code is set if none of the pressure switches respond. The TCM will continue to run the loss of prime test until pump pressure returns.

Theory of operation: The loss of prime test is used to prevent transmission faults, which can be caused by a lack of pump prime.

Transmission Effects: Vehicle will not move or transmission slips. Normal operation will continue if pump prime returns.

Possible causes:

- > Low transmission fluid level
- > PRNDL indicates a valid OD code in the hydraulic reverse position
- > Transmission fluid filter clogged or damaged
- > Transmission fluid filter improperly installed (Bolts loose or O-ring missing)
- > Oil pump - If a customer has a problem when the transmission is cold. Where someone shifts to reverse, reverse is engaged, and then shifts to OD and does not get OD (gets a neutral condition), and then can not get reverse or OD for 3-20 seconds, replace the oil pump. High side clearance in the oil pump will set a code 35. The pump will prime upon start-up, but as the torque converter purges air (drain down) the air will leak across the inner rotor into the pump suction port and cause a loss of prime right after the shift into OD. After 3 - 20 seconds, pump prime will return and normal operation will continue. The pump should be replaced only after all other possible causes above have been checked and verified.

Name of code: P1790(36) - Fault Immediately After Shift

When monitored: After a gear ratio error is stored.

Set condition: This code is set if the associated gear ratio code is stored within 1.3 seconds after a shift.

Theory of operation: This code will only be stored along with a 50 series code. If this code is set, it indicates the problem is mechanical in nature. When this code exists, diagnosing the transmission should be based on the associated gear ratio code and primarily mechanical causes should be considered.

Transmission Effects: None

Possible causes:

- > Mechanical causes as listed under associated gear ratio code.

Name of code: P1775(37) - Solenoid Switch Valve Latched in TCC Position

When monitored: During an attempted shift into 1st gear.

Set condition: This code is set if three unsuccessful attempts are made to get into 1st gear in one given key start.

Theory of operation: The solenoid switch valve (SSV) controls the direction of the transmission fluid when the LR/TCC solenoid is energized. The SSV will be in the downshifted position in 1st gear, thus directing the fluid to the LR clutch circuit. In 2nd, 3rd, and 4th, it will be in the upshifted position and directs the fluid into the torque converter clutch (TCC).

When shifting into 1st gear, a special hydraulic sequence is performed to ensure SSV movement into the downshifted position. The LR pressure switch is monitored to confirm SSV movement. If movement is not confirmed (the LR pressure switch does not close), 2nd gear is substituted for 1st.

Transmission Effects: Transmission will have no 1st gear (2nd gear will be substituted), and no EMCC operation and the MIL will illuminate after 5 minutes of substituted operation

Possible causes:

- > PRNDL indicates a valid OD code in the hydraulic reverse position
- > Valve body - Solenoid valve stuck in TCC position
- > High idle speed
- > Solenoid malfunction - LR pressure switch will not close
- > LR Pressure Switch Sense circuit shorted to battery

Name of code: P0740(38) - Torque Converter Clutch Control Circuit

When monitored: During Electronically Modulated Converter Clutch (EMCC)

Set condition:

a) The transmission must be in EMCC, with the input speed greater than 1750 RPM. The TCC/LR solenoid must achieve it's maximum duty cycle and still not be able to pull the engine speed within 60 RPM of input speed.

b) If the transmission is in FEMCC and the engine can slip the TCC by more than 100 RPM (Engine speed - Input speed) for 10 seconds.

The code will be set if one of these event happens three times at a throttle angle less than 30 degrees.

Theory of operation: When in 2nd, 3rd, or 4th gear, the torque converter clutch (TCC) can be locked when certain conditions are met. The TCC piston is electronically modulated by increasing the duty cycle of the LR/TCC solenoid until the torque converter slip difference (difference between engine and turbine speed) is within 60 RPM. Then the LR/TCC solenoid is fully energized (FEMCC / 100% duty cycle). Torque converter slip is monitored in FEMCC to ensure adequate clutch capacity.

GENERAL INFORMATION

Transmission Effects: EMCC will still be available after code is set. MIL will illuminate after 5 minutes of accumulated slip in FEMCC. The transmission will attempt normal operation (not in Limp-in) even after the MIL is illuminated.

Possible causes:

- > Worn pump bushing and/or failed torque converter - both should be replaced during a rebuild with code P0740(38) present
- > Solenoid pack.

Name of code: P0750(41) - LR Solenoid Circuit

P0755(42) - 2/4 Solenoid Circuit

P0760(43) - OD Solenoid Circuit

P0765(44) - UD Solenoid Circuit

When monitored: Ignition key is turned from off position to run position and/or ignition key is turned from crank position to run position, then every 10 seconds thereafter, or when a gear ratio or pressure switch error DTC is detected.

Set condition: All four solenoids are tested for continuity continuously immediately upon start up and during vehicle operation. For solenoids that are currently energized, power is momentarily interrupted, then reenergized. For solenoids that are not currently energized, the solenoid is momentarily energized, then deenergized. Under both situations, if an inductive spike is not sensed by the Transmission Control Module (TCM) during the continuity check, it is retested twice. If it fails the test the third time, the appropriate code is set.

SOLENOID APPLICATION CHART

| GEAR | UD | OD | REV | 2/4 | LR |
|---------|----|----|-----|-----|----|
| PARK | | | | | X |
| REVERSE | | | X | | X |
| NEUTRAL | | | | | X |
| 1ST | X | | | | X |
| 2ND | X | | | X | |
| 3RD | X | X | | | |
| 4TH | | X | | X | |

80cc4c0

Theory of operation: Four solenoids are used to control the friction elements (clutches). The continuity of the solenoids circuits are periodically tested. Each solenoid is turned on or off depending on it's current state. An inductive spike should be detected by the TCM during this test. If no spike is detected, the circuit is tested again to verify the failure. In addition to the periodic testing, the solenoid circuits are tested if a gear ratio or pres-

sure switch error occurs. In this case, one failure will result in the appropriate code being set.

Transmission Effects: The MIL will illuminate and the transmission goes into neutral if code is set above 35 Km/h (22 MPH), Limp-in mode when vehicle speed is below 35 Km/h (22 MPH).

Possible causes:

- > Open or shorted solenoid circuit(s) between TCM and solenoid pack.
- > Open ground circuit.
- > TCM connector problems.
- > Solenoid pack connector problem.
- > Solenoid Pack.
- > TCM

Name of code: P1776(47) - Solenoid Switch Valve Latched in LR Position

When monitored: Continuously when doing partial or full EMCC (PEMCC or FEMCC)

Set condition: If the transmission senses the LR pressure switch closing while performing PEMCC or FEMCC. This code will be set after two unsuccessful attempts to perform PEMCC or FEMCC.

Theory of operation: The solenoid switch valve (SSV) controls the direction of the transmission fluid when the LR/TCC solenoid is energized. SSV will be in the downshifted position in 1st gear, thus directing the fluid to the LR clutch circuits. In 2nd, 3rd, and 4th, the SSV will be in the upshifted position and directs the fluid into the torque converter clutch (TCC).

When doing PEMCC or FEMCC, the LR pressure switch should indicate no pressure if the SSV is in the TCC position. If the LR pressure switch indicates pressure while in PEMCC or FEMCC, EMCC operation is aborted and inhibited to avoid inadvertent application of the LR clutch. Partial EMCC will be attempted if the LR pressure switch does not indicate pressure. A second detection of LR pressure results in setting the code.

Transmission Effects: At speeds above 72 Km/h (45 MPH), EMCC is inhibited. Once speed falls below 72 Km/h (45 MPH), the transmission will go into Limp-in mode and the MIL will illuminate after 5 minutes of substituted operation.

Possible causes:

- > Valve body - Solenoid valve stuck in LR position
- > Intermittent short to ground or open circuit in LR Pressure Switch Sense circuit (with code 24 only)
- > Solenoid pack (with code P0841(24) only)
- > TCM (with code P0841(24) only)

Name of code: P1793(48) - TRD Link Communication Error

NOTE: The MIL will be lit for some engines that limit throttle after a TRD failure

When monitored: Whenever the engine is running

Set condition: This code is set when the TCM sends multiple torque reduction messages to the PCM and the TCM does not receive a response from the PCM.

Theory of operation: During high torque shifts the TCM will send a message requesting that the PCM reduce engine power until the shift is completed. This message is sent from the TCM to the Powertrain Control Module across the Torque Management Request Sense Circuit. The PCM will acknowledge the TCM request by sending a message across the PCI bus within a specific amount of time. The TRD Link communication is also tested periodically for operation whenever the engine is running and the vehicle is not moving with zero degrees throttle.

Transmission Effects: Maximum throttle angle used by TCM will be 54 degrees. As a result a customer may complain about loss of performance or of short shifting when driving aggressively.

Possible causes:

- > Sticky Throttle Position Sensor (TPS)
- > Wiring or Connector problems in the Torque Management Request Sense Circuit
- > PCM
- > TCM

Name of code: P0736(50) - Gear Ratio Error in Reverse

P0731(51) - Gear Ratio Error in 1st

P0732(52) - Gear Ratio Error in 2nd

P0733(53) - Gear Ratio Error in 3rd

P0734(54) - Gear Ratio Error in 4th

P0715(56) - Input Speed Sensor Error

P0720(57) - Output Speed Sensor Error

P1794(58) - Speed Sensor Ground Error

When monitored: The transmission gear ratio is monitored continuously while the transmission is in gear.

Set condition: This code is set if the gear ratio is not correct for a period of time.

- Codes 50 through 54 sets if the ratio of the input RPM (Nt) to the output RPM (No) does not match the given gear ratio.
- Code 56 sets if there is an excessive change in input RPM in any gear
- Code 57 sets if there is an excessive change in output RPM in any gear

- Code 58 sets after a TCM reset in neutral and Nt/No equals a ratio of input to output of 2.50

A hard code sets within 3 seconds, an intermittent code sets within 15 seconds.

Theory of operation: The transmission system uses two speed sensors, one to measure input RPM and one to measure output RPM. These inputs are essential for proper transmission operation. Therefore, the integrity of this data is verified through the following checks:

- 1) When in gear, if the gear ratio does not compare to a known gear ratio, the corresponding in-gear trouble code is set (codes 50 through 54).
- 2) An excessive change in input or output speeds indicating signal intermittent will result in codes 56 and/or 57 being set.
- 3) After a TCM reset in neutral, observing erratic output and input speed sensor signals indicates a loss of the common speed sensors ground. This sets a code 58.

Transmission Effects: The transmission will not go into Limp-in mode until three gear ratio error events occur in a given key start also the MIL will illuminate after 5 minutes of substituted operation. This allows for intermittent problems to correct themselves without opening the relay. However, if a gear ratio error develops, a code is always set, but if the condition corrects itself the transmission will continue without requiring the ignition key to be cycled on and off. Many different events could occur given the range of failures possible for codes 50 through 58. The following are a few examples:

- Codes 51, 52, 53, 54, 56, and 57 at speeds above 72 Km/h (45 MPH) - The appropriate code is set, EMCC is aborted and current gear is maintained. If while still traveling above 72 Km/h (45 MPH), the gear ratio becomes valid again, EMCC will reengage and normal operation will resume. If the gear ratio becomes intermittent and recovers three times in a given key start, the current gear will be maintained and EMCC inhibited, then the transmission will go into Limp-in mode if throttle is applied below 72 Km/h (45 MPH) or at 35 Km/h (22 MPH) with closed throttle.
- Codes 51, 52, 53, 54, 56, and 57 at speeds between 35 and 72 Km/h (22 and 45 MPH) - If one of these codes is set between 35 and 72 Km/h (22 and 45 MPH), the current gear will be maintained until the gear ratio problem corrects itself. If throttle is applied, the trans will go to 2nd gear. If this happens and the gear ratio problem goes away, normal operation will resume. If three gear ratio problems are identified in a given key start, the current gear will be frozen until throttle is applied.

GENERAL INFORMATION

The transmission will then go into Limp-in mode with throttle applied at speeds between 35 and 72 Km/h (22 and 45 MPH)

- Codes 51, 52, 53, 54, 56, and 57 at speeds below 35 Km/h (22 MPH) - If a gear ratio problem is identified below 35 Km/h (22 MPH), the transmission will immediately substitute second gear for the current gear. If the gear ratio problem goes away, normal operation will resume. If three gear ratio problems are identified in a given key start, the transmission will go into Limp-in mode.

Possible causes:

Code P0736(50) - Excludes geartrain failures which should be obvious upon disassembly

- > If code P0944(35) is also set, follow diagnostic procedure for code P0944(35) first
- > Valve body - #1 ball check or LR switch valve sticking - may also set code P0731(51)
- > Speed sensor or associated wiring - may also set codes P0731(51), P0715(56), or P0720(57)
- > Failed or slipping LR clutch - may also set code P0731(51)
 - LR seal leakage (Intermittent no drive or reverse)
 - Sticky LR accumulator seals (Intermittent no drive or reverse)
- > Failed reverse clutch (hard code)
 - OD/Rev lip seal leakage
 - Worn reaction shaft support seal rings
 - Snap ring out of position

Code P0731(51) - Excludes geartrain failures which should be obvious upon disassembly

- > If code P0944(35) is also set, follow diagnostic procedure for code P0944(35) first
- > Valve body - #1 ball check or LR switch valve sticking - may also set code P0736(56) or have no Reverse
- > Speed sensor or associated wiring - may also set codes P0736(50), P0715(56), or P0720(57)
- > Failed or intermittent slipping UD clutch - may also set P0732(52), or P0733(53)
 - UD seal leakage (intermittent)
 - Worn input clutch hub bushing (hard code at heavy throttle)
 - Sticky UD accumulator seals (intermittent)
 - Worn reaction shaft support seal rings (hard code at heavy throttle)
 - Solenoid pack (UD pressure in 4th gear)
- > Failed or slipping LR clutch - may also set code P0736(56) or have no Reverse
 - LR seal leakage (Intermittent)

- Sticky LR accumulator seals (Intermittent)
Code P0732(52) - Excludes geartrain failures which should be obvious upon disassembly

- > If code P0944(35) is also set, follow diagnostic procedure for code P0944(35) first
- > Failed or slipping 2/4 clutch - may also set code P0734(54)
 - 2/4 seal leakage (intermittent)
 - Sticky accumulator seals (intermittent)
- > Failed or intermittent slipping UD clutch - may also set code P0731(51) and/or P0733(53)
 - UD seal leakage (intermittent)
 - Worn input clutch hub bushing (hard code at heavy throttle)
 - Sticky UD accumulator seals (intermittent)
 - Worn reaction shaft support seal rings (hard code at heavy throttle)
 - Solenoid pack (UD pressure in 4th gear)

Code P0733(53) - Excludes geartrain failures which should be obvious upon disassembly

- > If code P0944(35) is also set, follow diagnostic procedure for code P0944(35) first
 - > Failed or slipping OD clutch - may also set code P0734(54)
 - OD and Reverse inner and outer lip seal leakage (usually hard code)
 - Sticky OD accumulator seals (intermittent)
 - Worn reaction shaft support seal rings (hard code at heavy throttle)
 - Broken OD/UD tapered snap ring - (hard code at heavy throttle)
 - > Failed or intermittent slipping UD clutch - may also set code P0731(51) and/or P0732(52)
 - UD seal leakage (intermittent)
 - Worn input clutch hub bushing (hard code at heavy throttle)
 - Sticky UD accumulator seals (intermittent)
 - Worn reaction shaft support seal rings (hard code at heavy throttle)
 - Solenoid pack (UD pressure in 4th gear)
- Code P0734(54) - Excludes geartrain failures which should be obvious upon disassembly
- > If code P0944(35) is also set, follow diagnostic procedure for code P0944(35) first
 - > Failed or slipping OD clutch - may also set code P0733(53)
 - OD and Reverse inner and outer lip seal leakage (usually hard code)
 - Sticky OD accumulator seals (intermittent)
 - Worn reaction shaft support seal rings (hard code at heavy throttle)

- Broken OD/UD tapered snap ring - (hard code at heavy throttle)
 - > Failed or slipping 2/4 clutch - may also set code P0732(52)
 - 2/4 seal leakage (intermittent)
 - Sticky accumulator seals (intermittent)
- Codes P0715(56) and P0720(57)
- > Failed input or output speed sensor (intermittent or hard code)
 - > Shorted or open wiring between TCM and speed sensor(s) (intermittent)
 - > Connector problems at 60 TCM connector and/or speed sensor connector
- Code P1794(58)
- > Open or shorted speed sensor ground (speed sensor ground is different from chassis ground)
 - > Open or shorted Temperature Sensor wiring to TRS
 - > TRS - Will also set code P1799(74)
 - > TCM

Name of code: P1797(71)- Manual Shift Overheat

When monitored: Whenever the engine is running.

Set condition:

- 1) If the engine temperature exceeds 124 C (255°F) while operating in AutoStick mode.
- 2) If the transmission temperature exceeds 135°C (275°F) while in AutoStick mode

Theory of operation: Transmission and engine temperatures are monitored during vehicle operation. If conditions occur causing the engine or transmission to overheat, the AutoStick mode will be canceled, and a code will be set.

Transmission Effects: The 3 position shift schedule that is used in non-AutoStick applications is substituted while operating in the AutoStick gear selector position. No Limp-in mode occurs.

Possible causes:

- > Engine overheat - refer to service information for diagnosis and repair
- > Transmission Overheat
 - Restricted transmission cooling system
 - Transmission fluid overfilled
 - Radiator fan not functioning properly
 - Extended driving in low gear

NOTE: Strenuous driving conditions may cause the vehicle to overheat. If the driver operates in or initiates AutoStick with an overheated vehicle, the code will be set.

Name of code: P0897(73) - Worn Out/Burnt Transmission Fluid

When monitored: At every Fully Electronically Modulated Converter Clutch (FEMCC) to Partial Electronically Modulated Converter Clutch (PEMCC) transition miles when A/C compressor clutch is being cycled.

Set condition: The code will be set if vehicle shudder is detected 20 times when the A/C clutch is cycled.

Theory of operation: While in 3rd or 4th gear FEMCC and just before the A/C clutch engages, the Powertrain Control Module (PCM) requests the Transmission Control Module (TCM) to momentarily establish PEMCC operation. If vehicle shudder is detected during the FEMCC to PEMCC transition, a counter is incremented. If the count reaches 20, the trouble code is set. The driver may then notice harsh bumps when the A/C clutch is being cycled, but vehicle shudder will be eliminated. After 35 OBDII (EURO STAGE III OBD) warm-up starts or if the code is cleared, PEMCC will be reactivated to see if shudder is still present. If one shudder event occurs, the code will be reset. Clearing the code and running battery disconnect with the DRBIII® is the only way to reset the shudder counter from 20 back to zero.

Transmission Effects: This code does not cause the transmission to go into Limp-in mode. However, once the code is set, FEMCC to PEMCC operation before the A/C clutch engagement will be disabled for 35 OBDII (EURO STAGE III OBD) warm up starts.

Possible causes:

- > Degraded transmission fluid
- > Wheels severely out of alignment
- > Internal torque converter problem

Name of code: P0218(75) - High Temperature Operation Activated.

When monitored: Whenever the engine is running.

Set condition: Immediately once the Overheat Shift Schedule is activated.

Theory of operation: If the transmission oil temperature rises above 115°C (240°F), the overheat shift schedule is activated refer to Transmission Operation as a function of Transmission Oil Temperature and the code is set. The DTC is an information code only and is being set to aid the technician in determining root cause of a customer driveability issue. The code is also intended to alert the technician to determine if a cooling system malfunction has occurred or if an additional transmission air to oil cooler should be added to the vehicle if the customer regularly drives in a manner that overheats the transmission. Extended operation above 115°C (240°F) will reduce the durability of the transmission and should be avoided. Correcting the cooling system malfunction

GENERAL INFORMATION

or installing an additional transmission oil cooler will improve transmission durability especially for customers who operate in city/construction stop and go traffic, tow trailers regularly, drive aggressively in low gear or drive regularly in mountainous areas.

Transmission effects: Information only code. - Overheat shift schedule was activated, no Limp-in condition occurs. 2nd gear partial EMCC above 40 Km/h (25 MPH), 3rd gear EMCC from 45-69 Km/h (28-43 MPH), delayed 3-4 upshift at 69 Km/h (43 MPH), early 4-3 coastdown at 66 Km/h (41 MPH), EMCC operation under all conditions above 40 Km/h (25 MPH) except at closed throttle or 1st gear.

Possible causes:

- Transmission Overfilled with Oil
- Engine cooling fan failure
- Engine thermostat stuck closed
- Radiator corroded or packed with dirt
- Transmission Oil Cooler Plugged
- Customer driving pattern requires additional transmission cooling

Name of code: P0884(76) - Power Up at Speed

When monitored: When TCM (transmission control module) initially powers-up.

Set condition: If the TCM powers up while in the "Drive" position and the vehicle is going above 32 Km/h (20 MPH), the code is set.

Theory of Operation: If a vehicle loses power to the TCM, the vehicle will go to the 2nd gear mode since there is no power available to control the transmission solenoids. However if power is restored, the TCM will power-up and normal operation will be restored. This DTC identifies that power to the TCM was restored when the gear selector was in a "Drive" position while the vehicle was moving at speeds above 32 Km/h (20 MPH). If someone shifts to Neutral and cycles the ignition key and quickly shifts to "Drive" while moving before the TCM comes out of its START ROUTINE, the DTC can be set. Therefore it is critical that this DTC diagnosis repair procedure should only be used if the vehicle is experiencing intermittent 2nd gear operation and subsequently a return to normal operation during normal driving.

Transmission Effects: No Limp-in condition. The DTC is for information only when trying to diagnosis intermittent 2nd gear operation and subsequently a return to normal operation.

Possible causes:

- No Problem if vehicle is started in "neutral" at speeds above 32 Km/h (20 MPH) and shifted quickly to "Drive" before TCM comes out of the START ROUTINE.

FOR INTERMITTENT 2ND GEAR OPERATION AND THEN A SUBSEQUENT RETURN TO NORMAL OPERATION WITHOUT CYCLING THE IGNITION KEY

- Intermittent Direct Battery connection between TCM (60-way pin 56) and battery.
- Intermittent Fused Ignition Switch Output between TCM (60-way pin 11) and ignition switch.
- Intermittent Ground to TCM (60 way pins 53 and 57).

Name of code: P1687(77) - No Communication with the MIC

When monitored: Continuously with key on.

Set condition: If no PCI bus messages are received from the Mechanical Instrument Cluster (MIC) for 25 seconds.

Theory of operation: The TCM communicates with the MIC using the PCI bus. It relies on certain information to function properly. The TCM continuously monitors the PCI bus to check for messages broadcast from the PCM.

Transmission effects: Possible improper TCM AutoStick configuration.

Possible causes:

- > Open or shorted PCI bus circuit from MIC
- > MIC
- > TCM (If other communications codes are stored in the TCM only)

Name of code: P1652(78) - Serial Communication Link Malfunction

When monitored: Continuously with key on.

Set condition: If no PCI bus messages are received by the Transmission Control Module (TCM) for 10 seconds.

Theory of operation: The TCM communicates with the other modules in the vehicle using the PCI bus. It relies on certain information to function properly. The TCM continuously monitors the PCI bus to check for messages broadcast from the certain modules.

Transmission Effects: Possible improper TCM AutoStick configuration and delayed 3-4 shifts. No EMCC and early 3-4 shifts for a few minutes after engine is started.

Possible causes:

- > Open or shorted PCI bus circuit from BCM
- > TCM

Name of code: P0562(79) Low Battery Voltage

When monitored: Continuously with engine running and Transmission Relay energized.

Set condition: If the voltage sensed at the Transmission Control Relay Output circuit (pins 16 and 17 at TCM) for 15 seconds.

Theory of operation: The Transmission system requires sufficient battery voltage in order to energize the transmission solenoids. The TCM continuously monitors the voltage available to the solenoids.

Transmission effects: At speeds above 72 Km/h (45 MPH) the transmission system will default to neutral. Below 72 Km/h (45 MPH) the transmission system will default to Limp-in mode and the MIL will illuminate after 5 minutes of substituted operation. Manual gear selection of Park, Reverse, Neutral and Second will be available.

Possible causes:

- > Charging system problem
- > Poor/High resistance connection between TCM and Battery/Alternator
- > TCM pin 16 and 17 high resistance or poor connection
- > TCM ground pins 53 and 57 high resistance or poor connection
- > High resistance in Transmission Control Relay contacts
- > TCM

Name of code: P0711(7A) - Transmission temperature sensor performance

When monitored: Every 7 milliseconds with the engine running and no loss of prime DTC set.

Set condition: A temperature reading of 80°F is not reached in the specified period of time

Theory of operation: The temperature sensor (thermistor) is used to sense the temperature of the transmission fluid. Transmission fluid temperature can affect shift quality, torque converter lock-up, and when and if some diagnostics are run. A failed temperature sensor could affect the OBD II diagnostics, therefore when a fault is detected in the temperature sensor circuit, transmission temperature will be based on a calculated temperature value.

Transmission Effects: When the fault is set, calculated temperature is substituted for measured temperature, however the fault code is stored only after three consecutive occurrences of the fault.

Possible causes:

- > Temperature sensor
- > Temperature sensor wiring circuit.
- > Internal controller

Name of code: P0712(7B) - Transmission temperature sensor low

When monitored: Every 7 milliseconds with the engine running and no loss of prime DTC set.

Set condition: Sensor output voltage less than 0.078v.

Theory of operation: The temperature sensor (thermistor) is used to sense the temperature of the transmission fluid. Transmission fluid temperature can affect shift quality, torque converter lock-up, and when and if some diagnostics are run. A failed temperature sensor could affect the OBD II diagnostics, therefore when a fault is detected in the temperature sensor circuit, transmission temperature will be based on a calculated temperature value.

Transmission effects: When the fault is set, calculated temperature is substituted for measured temperature, however the fault code is stored only after three consecutive occurrences of the fault.

Possible causes:

- > Temperature sensor
- > Temperature sensor wiring circuit.
- > Internal controller

Name of code: P0713(7C) - Transmission temperature sensor high

When monitored: Every 7 milliseconds with the engine running and no loss of prime DTC set.

Set condition: Sensor output voltage greater than 4.94v.

Theory of operation: The temperature sensor (thermistor) is used to sense the temperature of the transmission fluid. Transmission fluid temperature can affect shift quality, torque converter lock-up, and when and if some diagnostics are run. A failed temperature sensor could affect the OBD II diagnostics, therefore when a fault is detected in the temperature sensor circuit, transmission temperature will be based on a calculated temperature value.

Transmission effects: When the fault is set, calculated temperature is substituted for measured temperature, however the fault code is stored only after three consecutive occurrences of the fault.

Possible causes:

- > Temperature sensor
- > Temperature sensor wiring circuit.
- > Internal controller

Name of code: P0714(7D) - Transmission temperature sensor intermittent

When monitored: Every 7 milliseconds with the engine running and no loss of prime DTC set.

Set condition: Temperature reading change greater than maximum change allowed per loop.

Theory of operation: The temperature sensor (thermistor) is used to sense the temperature of the transmission fluid. Transmission fluid temperature can affect shift quality, torque converter lock-up, and when and if some diagnostics are run. A failed temperature sensor could affect the OBD II

GENERAL INFORMATION

diagnostics, therefore when a fault is detected in the temperature sensor circuit, transmission temperature will be based on a calculated temperature value.

Transmission effects: When the fault is set, calculated temperature is substituted for measured temperature, however the fault code is stored only after three consecutive occurrences of the fault.

Possible causes:

- > Temperature sensor
- > Temperature sensor wiring circuit.
- > Internal controller

3.3.9 QUICK LEARN

The Quick Learn function customizes adaptive parameters of the TCM to the transmission characteristics of a vehicle. This gives the customer improved “as received” shift quality compared to the initial parameters stored in the TCM.

Notes about Quick Learn Features

The nature of the Quick Learn function requires that certain features must be taken into consideration.

- > Quick Learn should generally not be used as a repair procedure unless directed by a repair or diagnostic procedure. If the transmission system is exhibiting a problem that you think is caused by an invalid CVI, you should try to relearn the value by performing the appropriate driving maneuvers. In most cases, if quick learn makes a vehicle shift better, the vehicle will return with the same problem.
- > Before performing Quick Learn, it is imperative that the vehicle be shifted into OD with the engine running and the oil level set to the correct level. This step will purge air from the clutch circuits to prevent erroneous clutch volume values which could cause poor initial shift quality.
- > If an unused TCM is installed on a vehicle with a HOT engine, Quick Learn will cause the TCM to report a cold calculated oil temperature. This requires monitoring the calculated oil temperature using the DRBIII®. If the temperature is below 15°C (60°F), the transmission must be run at idle or driven in gear until it goes above 15°C (60°F). If the temperature is above 93°C (200°F), the transmission must cool to below 93°C (200°F).
- > First gear is engaged in overdrive after Quick Learn is completed. Place the vehicle in park after performing Quick Learn.

The Quick Learn function should be performed:

- Upon installation of a new service TCM
- After replacement or rebuild of internal transmission components or the torque converter
- If one or more of the clutch volumes indexes (CVI'S) contain skewed readings because of abnormal conditions.

To perform the Quick Learn procedure, the following conditions must be met.

- It is imperative that the vehicle be shifted into OD with the engine running and the oil level set to the correct level. This step will purge the air in the clutch circuits to prevent erroneous clutch volume values, which could cause poor initial shift quality.
- The brakes must be applied.
- The engine must be idling.
- The throttle angle (TP sensor) must be less than 3 degrees.
- The shift lever position must stay in neutral until prompted to shift into OD.
- The shift lever must stay in OD after the “Shift to Overdrive” prompt until the DRBIII® indicates the procedure is complete.
- The oil temperature must be between 15°C (60°F) and 93°C (200°F).

NOTE: The above conditions must be maintained during the procedure to keep the procedure from being aborted.

The Quick Learn procedure is performed with the DRBIII® by selecting “Transmission” system then “Miscellaneous” functions, then “Quick Learn”. Follow the procedure instructions displayed on the DRBIII®.

3.3.10 CLUTCH VOLUMES

The LR clutch volume is updated when doing a 2-1 or 3-1 coast down shift. The transmission temperature must be between 21-49°C (70-120°F). The clutch volume should be between 35 and 83.

The 2/4 clutch volume is updated when doing a 1-2 shift. The transmission temperature must be above 43°C (110°F). The clutch volume should be between 20 and 77.

The OD clutch volume is updated when doing a 2-3 shift. The transmission temperature must be above 43°C (110°F). The clutch volume should be between 40 and 150.

The UD clutch volume is updated when doing a 4-3 or 4-2 shift. The transmission temperature must be above 43°C (110°F). The clutch volume should be between 24 and 70.

3.3.11 ELECTRONIC PINION FACTOR (IF APPLICABLE)

Using the following steps, the pinion factor can be checked and/or reset using the DRBIII®:

1. Select Transmission system, then Miscellaneous functions, then Pinion Factor. The DRBIII® will display the current tire size.
2. If the tire size is incorrect, press the Enter key and then select the correct size.
3. Press the Page Back key to exit the reset procedure.

Notes About Electronic Pinion Factor Features

The nature of the electronic pinion factor requires that certain features must be taken into consideration.

- > If no pinion factor is stored in an installed TCM, the vehicle speedometer will not operate, engine speed will be limited to 2300 RPM, and catalyist damage may occur.
- > Selecting a wrong tire size will cause the speedometer to be inaccurate and will also cause any speed related features to operate improperly.

NOTE: After replacing the TCM, you must reprogram pinion factor

3.4 USING THE DRBIII®

Refer to the DRBIII® users guide for instructions and assistance with reading trouble codes, erasing trouble codes, and other DRBIII® functions.

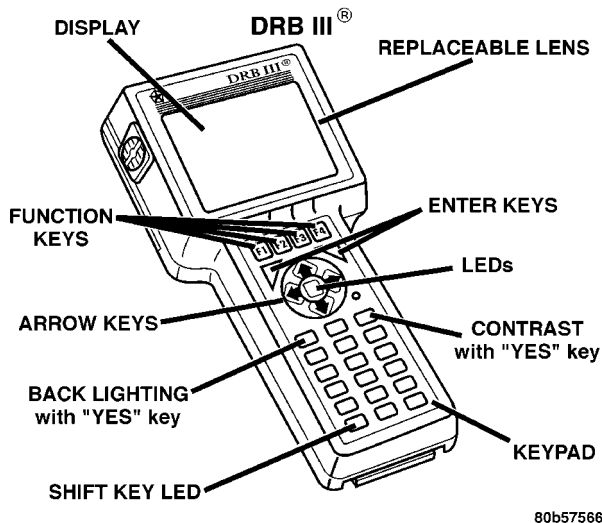

3.5 DRBIII® ERROR MESSAGES

Under normal operation, the DRBIII® will display one of only two error messages:

- User-Requested WARM Boot
- User-Requested COLD Boot

If the DRBIII® should display any other error message, record the entire display and call the S.T.A.R.. Center.

3.5.1 DRBIII® DOES NOT POWER UP (BLANK SCREEN)

If the LED's do not light or no sound is emitted at start up, check for loose cable connections or a bad cable. Check the vehicle battery voltage. A minimum of 11 volts is required to adequately power the DRBIII®.

If all connections are proper between the DRBIII® and the vehicle or other devices, and the vehicle battery is fully charged, an inoperative DRBIII® may be the result of faulty cable or vehicle wiring. For a blank screen, refer to the appropriate Body Diagnostic manual.

3.5.2 DISPLAY IS NOT VISIBLE

Low temperatures will affect the visibility of the display. Adjust the contrast to compensate for this condition.

3.6 TRANSMISSION SIMULATOR (MILLER TOOL # 8333) AND ELECTRONIC TRANSMISSION ADAPTER KIT (MILLER TOOL #8333-1A)

NOTE: Remove the starter Relay when using the transmission simulator

- Failure to remove the Starter Relay can cause a PCM - No Response condition.
- The removal of the Starter Relay will also prevent the engine from starting in gear.
- The Transmission Simulator will not accurately diagnose intermittent faults.

The transmission simulator, simply put, is an electronic device that simulates the electronic functions of any EATX or NGC controlled transmission. The Simulators basic function is to aid the technician in determining if an internal transmission problem exists or if the problem resides in the vehicle wiring or control module. It is only useful for electrical problems. It will not aid in the diagnosis of a failed mechanical component, but it can tell you that the control module and wiring are working properly and that the problem is internal.

The ignition switch should be in the lock position before attempting to install the simulator. Follow all instructions included with the simulator. If the feedback from the simulator is in doubt, you can verify it's operation by installing it on a known good vehicle. A "known good vehicle" would be defined as a vehicle that does not set any DTC's and drives and shifts as expected.

GENERAL INFORMATION

One important point to remember is that the Simulator receives its power from the Trans Relay Output circuit. If the transmission system is in Limp-in (Relay open), the simulator will not operate. This is not really an indication of a problem, but an additional symptom. If the simulator does not power up ("P" led lit), this is an indication that the problem is still present with the simulator hooked up. This indicates that the problem is in the wiring or control module and not the transmission.

Miller Tool # 8333-1A consists of the adapter cables and overlay necessary to adapt the simulator to TE/AE/LE/RLE transmissions.

4.0 DISCLAIMERS, SAFETY, AND WARNINGS

4.1 DISCLAIMERS

All information, illustrations, and specifications contained in this manual are based on the latest information available at the time of publication. The right is reserved to make changes at any time without notice.

4.2 SAFETY

4.2.1 TECHNICIAN SAFETY INFORMATION

WARNING: ENGINES PRODUCE CARBON MONOXIDE THAT IS ODORLESS, CAUSES SLOWER REACTION TIME, AND CAN LEAD TO SERIOUS INJURY. WHEN THE ENGINE IS OPERATING KEEP SERVICE AREAS WELL VENTILATED OR ATTACH THE VEHICLE EXHAUST SYSTEM TO THE SHOP EXHAUST REMOVAL SYSTEM.

Set the parking brake and block the wheels before testing or repairing the vehicle. It is especially important to block the wheels on front-wheel drive vehicles: the parking brake does not hold the drive wheels.

Some operations in this manual require that hydraulic tubes, hoses, and fittings, disconnected for inspection or testing purposes. These systems, when fully charged, contain fluid at high pressure.

Before disconnecting any hydraulic tubes, hoses, and fittings, be sure that the system is fully depressurized.

When servicing a vehicle, always wear eye protection, and remove any metal jewelry such as watchbands or bracelets that might make an inadvertent electrical contact.

When diagnosing a Transmission system problem, it is important to follow approved procedures

where applicable. These procedures can be found in the service information. Following these procedures is very important to the safety of individuals performing diagnostic tests.

4.2.2 VEHICLE PREPARATION FOR TESTING

Make sure the vehicle being tested has a fully charged battery. If it does not, false diagnostic DTC's or error messages may occur. It is extremely important that accurate shift lever position data is available to the TCM. The accuracy of any DTC found in memory is doubtful unless the Shift Lever Test, performed on the DRBIII® Scan Tool, passes without failure.

4.2.3 SERVICING SUB-ASSEMBLIES

Some components of the Transmission system are intended to be serviced in assembly only. Attempting to remove or repair certain system sub-components may result in personal injury and/or improper system operation. Only those components with approved repair and installation procedures in the service information should be serviced.

4.2.4 DRBIII® SAFETY INFORMATION

WARNING: EXCEEDING THE LIMITS OF THE DRBIII® MULTIMETER IS DANGEROUS. IT CAN EXPOSE YOU TO SERIOUS OR POSSIBLY FATAL INJURY. CAREFULLY READ AND UNDERSTAND THE CAUTIONS AND THE SPECIFICATION LIMITS.

- Follow the vehicle manufacturer's service specifications at all times.
- Do not use the DRBIII® if it has been damaged.
- Do not use the test leads if the insulation is damaged or if metal is exposed.
- To avoid electrical shock, do not touch the test leads, tips or the circuit being tested.
- Choose the proper range and function for the measurement. Do not try voltage or current measurements that may exceed the rated capacity.
- Do not exceed the limits shown in the table.

| FUNCTION | INPUT LIMIT |
|---|---|
| Volts | 0 - 500 volts peak AC 0 - 500 volts DC |
| Ohms (resistance)* | 0 - 1.12 megohms |
| Frequency Measured Frequency Generated | 0 - 10 kHz |
| Temperature | -58 - 1100°F -50 - 600°C |

*Ohms cannot be measured if voltage is present. Ohms can be measured only in a non-powered circuit.

- Voltage between any terminal and ground must not exceed 500v DC or 500v peak AC.
- Use caution when measured voltage above 25v DC or 25v AC.
- The circuit being tested must be protected by a 10A fuse or circuit breaker.
- Use the low current shunt to measure circuits up to 10A. Use the high current clamp to measure circuits exceeding 10A.
- When testing for the presence of voltage or current, make sure the meter is functioning correctly. Take a reading of a known voltage or current before accepting a zero reading.
- When measuring current, connect the meter in series with the load.
- Disconnect the live test lead before disconnecting the common test lead.
- When using the meter function, keep the DRBIII® away from spark plug or coil wires to avoid measuring error from outside interference.

4.3 WARNINGS

4.3.1 VEHICLE DAMAGE WARNINGS

Before disconnecting any control module, make sure the ignition is “lock” position. Failure to do so could damage the module.

When testing voltage or continuity at any control module, use the terminal side (not the wire end) of the connector. Do not probe a wire through the insulation: this will damage the wire and eventually cause the wire to fail because of corrosion.

Be careful when performing electrical tests so as to prevent accidental shorting of terminals. Such mistakes can damage fuses or components. Also, a second DTC could be set, making diagnosis of the original problem more difficult.

When replacing a blown fuse, it is important to use only a fuse having the correct amperage rating. The use of a fuse with a rating other than indicated may result in a dangerous electrical system overload. If a properly rated fuse continues to blow, it indicates a problem in the circuit that must be corrected.

4.3.2 ROAD TESTING A COMPLAINT VEHICLE

Some complaints will require a test drive as part of the repair verification procedure. The purpose of the test drive is to try to duplicate the diagnostic DTC or symptom condition.

CAUTION: Before road testing a vehicle, be sure that all components are reassembled. During the test drive, do not try to read the DRBIII® screen while in motion. Do not hang the DRBIII® from the rear view mirror or operate it yourself. Have an assistant available to operate the DRBIII®.

Road testing is an essential step in the diagnostic process that must not be overlooked. Along with the diagnostic information obtained from the DRBIII® Scan Tool and the original customer concern, the road test helps verify the problem was current and any repairs performed, fixed the vehicle correctly. Always operate and observe the vehicle under actual driving conditions.

Just as important as the road test is, there are preliminary inspections that should be performed prior to the road test. Always check the fluid level and condition before taking the vehicle on a road test. Determine if an incorrect fluid type is being used, improper fluid will result in erratic transmission operation. Some of the conditions of incorrect fluid level are as follows:

- Delayed engagement
- Poor shifting or erratic shifting
- Excessive noise
- Overheating

The next step is to verify that the shifter is correctly adjusted. If the shifter is incorrectly adjusted, a number of complaints can result.

The TCM monitors the Shift Lever Position (SLP) Sensor continuously. If the shifter is incorrectly adjusted, the TCM will sense a shift lever position that is not correct for the gear chosen by the driver. This may cause a DTC to be set.

The following complaints may also be the result of an incorrectly adjusted or worn shifter:

- Delayed clutch engagement
- Erratic shifts
- Vehicle will drive in neutral
- Engine will not crank in park or neutral
- Shifter will be able to be moved without the key in the ignition
- Not able to remove the ignition key in park
- Parking pawl will not engage properly

The shifter should also be adjusted when replacing the Transmission, repairing the valve body, or when repairing any component between the shift lever and the Transmission.

Some questions to ask yourself when performing the road test are as follows:

- Is the complaint or concern what you think the problem is, based on the drivers description of the problem?

GENERAL INFORMATION

- Is the Transmission operating normally, or is there a real problem?
- When does the problem occur?
- Is the problem only in one gear range?
- What temperature does the problem occur?
- Does the vehicle have to sit over night for the problem to occur?
- Does the transmission go into Limp-in mode?

4.3.3 ELECTRONIC PINION FACTOR WARNINGS (IF APPLICABLE)

The pinion factor must be set when replacing the TCM.

NOTE: The pinion factor is a fixed number and cannot be changed or updated in some vehicle applications. If the pinion factor is not set or incorrectly set, any speed related functions will not operate correctly i.e. speedometer, speed control, rolling door locks, other control modules will be affected that depend on speed information.

4.3.4 BULLETINS AND RECALLS

Always perform all Safety Recalls and Technical Service Bulletins that are applicable to the problem.

5.0 REQUIRED TOOLS AND EQUIPMENT

- > DRBIII® (diagnostic read-out box) – Must be at latest release level.
- > Transmission Simulator (Miller # 8333)
- > Electronic Transmission Adapter Kit (Miller # 8333-1A)
- > Jumper wires
- > Test Light (minimum of 25 ohms of resistance)
- > Ohmmeter
- > Voltmeter
- > Pressure gauge (0-300 PSI)

6.0 GLOSSARY OF TERMS

6.1 ACRONYMS

| | |
|------------|----------------------|
| BCM | -Body Control Module |
| CKT | -Circuit |

| | |
|----------------|--|
| CVI | -Clutch Volume Index |
| DLC | -Data Link Connector |
| DRBIII® | -Diagnostic Readout Box |
| DTC | -Diagnostic Trouble Code |
| EATX | -Electronic Automatic Transmission |
| EMCC | -Electronically Modulated Converter Clutch |
| FCM | -Front Control Module (part of the IPM system) |
| IOD | -Ignition off-draw |
| IPM | -Intelligent Power Module |
| IRT | -Intelligent Recovery Timer |
| ISS | -Input Speed Sensor |
| LED | -Light Emitting Diode |
| LR | -Low/reverse Clutch or Pressure Switch |
| LU | -Lockup |
| MIC | -Mechanical Instrument Cluster |
| MIL | -Malfunction Indicator Lamp |
| OBDII | -On Board Diagnostics |
| OD | -Overdrive Clutch or Pressure Switch |
| OSS | -Output Speed Sensor |
| PCM | -Powertrain Control Module |
| PEMCC | -Partial Electronically Modulated Converter Clutch |
| PLU | -Partial Lockup |
| REV | -Reverse Clutch |
| SLPK | -Solenoid Pack |
| SSV | -Solenoid Switch Valve |
| SW | -Switch |
| TCC | -Torque Converter Clutch |
| TCM | -Transmission Control Module |
| TP | -Throttle Position |
| TRD | -Torque Reduction |
| TRS | -Transmission Range Sensor |
| UD | -Underdrive Clutch |
| 2/4 | -2nd and 4th gear Clutch or Pressure Switch |

6.2 DEFINITIONS

OBDII (EURO STAGE III OBD) Trip - A vehicle start and drive cycle such that all once per trip diagnostic monitors have run.

Key Start - A vehicle start and run cycle of at least 20 seconds.

Warm-up Cycle - A vehicle start and run cycle such that the engine coolant must rise to at least 71°C (160°F) and must rise by at least 4.4°C (40°F) from initial start up. To count as a warm-up cycle, no DTC may occur during the cycle.

7.0

DIAGNOSTIC INFORMATION AND
PROCEDURES

Symptom:

***NO RESPONSE FROM TRANSMISSION CONTROL MODULE**

| POSSIBLE CAUSES |
|---|
| NO RESPONSE FROM TRANSMISSION CONTROL MODULE FUSED IGNITION SWITCH OUTPUT (RUN/ST) CIRCUIT OPEN FUSED IGNITION SWITCH OUTPUT (START) CIRCUIT OPEN FUSED IGNITION SWITCH OUTPUT (START) CIRCUIT SHORT FUSED B(+) CIRCUIT OPEN GROUND CIRCUIT(S) OPEN OPEN PCI BUS CIRCUIT TRANSMISSION CONTROL MODULE |

| TEST | ACTION | APPLICABILITY |
|------|---|---------------|
| 1 | Ignition on, engine not running. Note: As soon as one or more module communicates with the DRB, answer the question. With the DRB, attempt to communicate with the Airbag Control Module (ACM). With the DRB, attempt to communicate with the Instrument Cluster. Was the DRB able to I/D or establish communications with either of the modules? Yes → Go To 2 No → Refer to the Body Communication category and perform the symptom PCI Bus Communication Failure. Perform 42RLE TRANSMISSION VERIFICATION TEST - VER 1. | All |
| 2 | Turn the ignition off to the lock position. Disconnect the TCM harness connector. Ignition on, engine not running. Using a 12-volt test light connected to ground, check the Fused Ignition Switch Output (Run/St) circuit. NOTE: The test light must illuminate brightly. Compare the brightness to that of a direct connection to the battery. Does the test light illuminate brightly? Yes → Go To 3 No → Repair the Fused Ignition Switch Output (Run/St) circuit for an open. Refer to the wiring diagrams location in the Service Information. Perform 42RLE TRANSMISSION VERIFICATION TEST - VER 1. | All |

***NO RESPONSE FROM TRANSMISSION CONTROL MODULE — Continued**

| TEST | ACTION | APPLICABILITY |
|------|--|---------------|
| 3 | <p>Turn the ignition off to the lock position. Disconnect the TCM harness connector. Remove the starter relay from the PDC. Using a 12-volt test light connected to ground, check the Fused Ignition Switch Output (Start) circuit. NOTE: The test light must illuminate brightly. Compare the brightness to that of a direct connection to the battery. Observe the test light while momentarily turning the ignition switch to the Start position. Does the test light illuminate brightly?</p> <p style="padding-left: 40px;">Yes → Go To 4</p> <p style="padding-left: 40px;">No → Repair the Fused Ignition Switch Output (Start) circuit for an open. Refer to the wiring diagrams located in the Service Information. Perform 42RLE TRANSMISSION VERIFICATION TEST - VER 1.</p> | All |
| 4 | <p>Turn the ignition off to the lock position. Disconnect the TCM harness connector. With a voltmeter in the millivolt scale, measure the voltage of the Fused Ignition Switch Output (Start) circuit. NOTE: A no response condition can exist if voltage is present on this circuit with the ignition switch in any position except for the Start position. NOTE: Voltage up to .080 millivolts can cause this condition. NOTE: Check for after market components that could cause this condition. Perform this step with the Ignition Switch in every position except for the Start position. Is any voltage present?</p> <p style="padding-left: 40px;">Yes → Repair the Fused Ignition Switch Output (Start) circuit for a short to voltage. Refer to the wiring diagrams located in the Service Information. Perform 42RLE TRANSMISSION VERIFICATION TEST - VER 1.</p> <p style="padding-left: 40px;">No → Go To 5</p> <p>Note: Reinstall the original Starter Relay.</p> | All |
| 5 | <p>Turn the ignition off. Disconnect the TCM harness connector. Using a 12-volt test light connected to ground, check the Fused B(+) circuit. NOTE: The test light must illuminate brightly. Compare the brightness to that of a direct connection to the battery. Does the test light illuminate brightly?</p> <p style="padding-left: 40px;">Yes → Go To 6</p> <p style="padding-left: 40px;">No → Repair the Fused B(+) circuit for an open. Refer to the wiring diagrams located in the Service Information. Perform 42RLE TRANSMISSION VERIFICATION TEST - VER 1.</p> | All |

***NO RESPONSE FROM TRANSMISSION CONTROL MODULE — Continued**

| TEST | ACTION | APPLICABILITY |
|------|--|---------------|
| 6 | <p>Turn the ignition off to the lock position. Disconnect the TCM harness connector. Using a 12-volt test light connected to 12-volts, check each ground circuit in the TCM harness connector. NOTE: The test light must illuminate brightly. Compare the brightness to that of a direct connection to the battery. Does the test light illuminate brightly at all the ground circuits?</p> <p>Yes → Go To 7</p> <p>No → Repair the Ground circuit(s) for an open. Check the main ground connection to engine block and/or chassis. Refer to the wiring diagrams located in the Service Information. Perform 42RLE TRANSMISSION VERIFICATION TEST - VER 1.</p> | All |
| 7 | <p>Note: Ensure there is PCI Bus communication with other modules on the vehicle before proceeding. If not, refer to the symptom list from the menu and repair as necessary. Disconnect the TCM harness connector. Use Scope input cable CH7058, Cable to Probe adapter CH7062, and the red and black test probes. Connect the scope input cable to the channel one connector on the DRB. Attach the red and black leads and the cable to probe adapter to the scope input cable. With the DRBIII® select Pep Module Tools. Select lab scope. Select Live Data. Select 12 volt square wave. Press F2 for Scope. Press F2 and use the down arrow to set voltage range to 20 volts. Set Probe to x10. Press F2 again when complete. Connect the Black lead to the chassis ground. Connect the Red lead to the PCI Bus circuit in the TCM connector. Turn the ignition on. Observe the voltage display on the DRB Lab Scope. Does the voltage pulse from 0 to approximately 7.5 volts?</p> <p>Yes → Go To 8</p> <p>No → Repair the PCI Bus circuit for an open. Perform 42RLE TRANSMISSION VERIFICATION TEST - VER 1.</p> | All |
| 8 | <p>Using the schematics as a guide, inspect the wiring and connectors. Repair as necessary. Pay particular attention to all power and ground circuits. If there are no possible causes remaining, view repair.</p> <p>Repair</p> <p>Replace the Transmission Control Module in accordance with the service information. WITH THE DRBIII® PERFORM QUICK LEARN. Perform 42RLE TRANSMISSION VERIFICATION TEST - VER 1.</p> | All |

Symptom:

P0122-THROTTLE POSITION SENSOR/APPS LOW

When Monitored and Set Condition:

P0122-THROTTLE POSITION SENSOR/APPS LOW

When Monitored: Continuously with the ignition on and engine running.

Set Condition: This DTC will set if the monitored TPS voltage drops below .078 volts for the period of 0.48 seconds.

POSSIBLE CAUSES

ENGINE TPS DTC'S PRESENT
 TPS SIGNAL CIRCUIT HIGH RESISTANCE
 TRANSMISSION CONTROL MODULE
 INTERMITTENT WIRING AND CONNECTORS

| TEST | ACTION | APPLICABILITY |
|------|---|---------------|
| 1 | <p>NOTE: Low fluid level can be the cause of many Transmission problems. If the fluid level is low, locate and repair the leak, then check and adjust the fluid level per the Service Information.</p> <p>NOTE: Always perform diagnostics with a fully charged battery to avoid false symptoms.</p> <p>With the DRBIII®, read the engine DTC's. Check and repair all engine DTC's prior to performing Transmission Symptom Diagnostics.</p> <p>With the DRBIII®, read Transmission DTC's. Record all DTC's and 1 Trip Failures.</p> <p>NOTE: Diagnose 1 Trip Failures as a fully matured DTC.</p> <p>Using the wiring diagram/schematic as a guide, inspect the wiring and connectors. Repair as necessary.</p> <p>Perform the Shift Lever Position Test. If the test does not pass, refer to Symptom test for P0706 Check Shifter Signal.</p> <p>For Gear Ratio DTC's, check and record all CVI's.</p> <p>Most DTC's set on start up but some must be set by driving the vehicle such that all diagnostic monitors have run.</p> <p>NOTE: Verify flash level of Transmission Control Module. Some problems are corrected by software upgrades to the Transmission Control Module.</p> <p>NOTE: Check for applicable TSB's related to the symptom.</p> <p>Perform this procedure prior to Symptom diagnosis.</p> <p>Continue Go To 2</p> | All |
| 2 | <p>With the DRBIII®, check Engine DTC's.</p> <p>Are there any Engine TPS related DTCs present?</p> <p>Yes → Refer to the Powertrain category and perform the appropriate symptom. Perform 42RLE TRANSMISSION VERIFICATION TEST - VER 1.</p> <p>No → Go To 3</p> | All |

P0122-THROTTLE POSITION SENSOR/APPS LOW — Continued

| TEST | ACTION | APPLICABILITY |
|------|---|---------------|
| 3 | <p>With the DRBIII® in Transmission Sensors, read the TPS voltage. Is the TPS voltage below 0.5 volts?</p> <p>Yes → Go To 4</p> <p>No → Go To 6</p> | All |
| 4 | <p>Ignition on, engine not running. With the DRBIII® in Transmission Sensors, record the TPS voltage. While back probing the TCM harness connector, measure the voltage of the TPS Signal circuit. Compare the voltage readings between the DRBIII® and the reading from the digital multi meter. Are the voltages within 0.1 volt of each other?</p> <p>Yes → Repair the TPS signal circuit between the TCM harness connector and the splice for high resistance. Perform 42RLE TRANSMISSION VERIFICATION TEST - VER 1.</p> <p>No → Go To 5</p> | All |
| 5 | <p>Using the schematics as a guide, inspect the wiring and connectors. Repair as necessary. Pay particular attention to all power and ground circuits. If there are no possible causes remaining, view repair.</p> <p>Repair</p> <p>Replace the Transmission Control Module per the Service information. WITH THE DRBIII® PERFORM QUICK LEARN. Perform 42RLE TRANSMISSION VERIFICATION TEST - VER 1.</p> | All |
| 6 | <p>The conditions necessary to set this DTC are not present at this time. Using the schematics as a guide, inspect the wiring and connectors specific to this circuit. Wiggle the wires while checking for shorts and open circuits. Pay particular attention to the point where the TPS signal and sensor ground circuits splice off from the engine circuits. With the DRBIII®, check the EATX EVENT DATA to help identify the conditions in which the DTC was set. Were there any problems found?</p> <p>Yes → Repair as necessary. Perform 42RLE TRANSMISSION VERIFICATION TEST - VER 1.</p> <p>No → Test Complete.</p> | All |

Symptom:

P0123-THROTTLE POSITION SENSOR/APPS HIGH

When Monitored and Set Condition:

P0123-THROTTLE POSITION SENSOR/APPS HIGH

When Monitored: Continuously with the ignition on and engine running.

Set Condition: This DTC will set if the monitored TPS voltage rises above 4.94 volts for the period of 0.48 seconds.

POSSIBLE CAUSES

ENGINE TPS DTC'S PRESENT
 SENSOR GROUND CIRCUIT OPEN TO TCM
 TPS SIGNAL CIRCUIT OPEN TO TCM
 TRANSMISSION CONTROL MODULE
 INTERMITTENT WIRING AND CONNECTORS

| TEST | ACTION | APPLICABILITY |
|------|---|---------------|
| 1 | <p>NOTE: Low fluid level can be the cause of many Transmission problems. If the fluid level is low, locate and repair the leak, then check and adjust the fluid level per the Service Information.</p> <p>NOTE: Always perform diagnostics with a fully charged battery to avoid false symptoms.</p> <p>With the DRBIII®, read the engine DTC's. Check and repair all engine DTC's prior to performing Transmission Symptom Diagnostics.</p> <p>With the DRBIII®, read Transmission DTC's. Record all DTC's and 1 Trip Failures.</p> <p>NOTE: Diagnose 1 Trip Failures as a fully matured DTC.</p> <p>Using the wiring diagram/schematic as a guide, inspect the wiring and connectors. Repair as necessary.</p> <p>Perform the Shift Lever Position Test. If the test does not pass, refer to Symptom test for P0706 Check Shifter Signal.</p> <p>For Gear Ratio DTC's, check and record all CVI's.</p> <p>Most DTC's set on start up but some must be set by driving the vehicle such that all diagnostic monitors have run.</p> <p>NOTE: Verify flash level of Transmission Control Module. Some problems are corrected by software upgrades to the Transmission Control Module.</p> <p>NOTE: Check for applicable TSB's related to the symptom.</p> <p>Perform this procedure prior to Symptom diagnosis.</p> <p>Continue Go To 2</p> | All |
| 2 | <p>With the DRBIII®, check Engine DTC's.</p> <p>Are there any Engine TPS related DTCs present?</p> <p>Yes → Refer to the Powertrain category and perform the appropriate symptom. Perform 42RLE TRANSMISSION VERIFICATION TEST - VER 1.</p> <p>No → Go To 3</p> | All |

P0123-THROTTLE POSITION SENSOR/APPS HIGH — Continued

| TEST | ACTION | APPLICABILITY |
|------|---|---------------|
| 3 | <p>With the DRBIII® in Transmission Sensors, read the TPS voltage. Is the TPS voltage above 4.5 volts?</p> <p>Yes → Go To 4</p> <p>No → Go To 7</p> | All |
| 4 | <p>Turn the ignition off to the lock position. Disconnect the TPS harness connector. Disconnect the TCM harness connector. Note: Check connectors - Clean/repair as necessary. Measure the resistance of the TPS Signal Circuit from the TCM harness connector to the TPS harness connector. Is the resistance below 5.0 ohms?</p> <p>Yes → Go To 5</p> <p>No → Repair the TPS Signal circuit between the TCM harness connector and the splice for an open. Perform 42RLE TRANSMISSION VERIFICATION TEST - VER 1.</p> | All |
| 5 | <p>Turn the ignition off to the lock position. Disconnect the TPS harness connector. Disconnect the TCM harness connector. Note: Check connectors - Clean/repair as necessary. Measure the resistance of the Sensor Ground circuit between the TPS harness connector and the Transmission Control Module harness connector. Is the resistance below 5.0 ohms?</p> <p>Yes → Go To 6</p> <p>No → Repair the Sensor Ground circuit between the TCM harness connector and the splice for an open. Perform 42RLE TRANSMISSION VERIFICATION TEST - VER 1.</p> | All |
| 6 | <p>Using the schematics as a guide, inspect the wiring and connectors. Repair as necessary. Pay particular attention to all power and ground circuits. If there are no possible causes remaining, view repair.</p> <p>Repair</p> <p>Replace the Transmission Control Module per the Service Information. WITH THE DRBIII® PERFORM QUICK LEARN. Perform 42RLE TRANSMISSION VERIFICATION TEST - VER 1.</p> | All |
| 7 | <p>The conditions necessary to set this DTC are not present at this time. Using the schematics as a guide, inspect the wiring and connectors specific to this circuit. Wiggle the wires while checking for shorts and open circuits. Pay particular attention to the point where the TPS signal and sensor ground circuits splice off from the engine circuits. With the DRBIII®, check the EATX EVENT DATA to help identify the conditions in which the DTC was set. Were there any problems found?</p> <p>Yes → Repair as necessary. Perform 42RLE TRANSMISSION VERIFICATION TEST - VER 1.</p> <p>No → Test Complete.</p> | All |

Symptom:**P0124- THROTTLE POSITION SENSOR/APPS INTERMITTENT****When Monitored and Set Condition:****P0124- THROTTLE POSITION SENSOR/APPS INTERMITTENT**

When Monitored: Continuously with the ignition on and engine running.

Set Condition: This DTC will set with a throttle angle between 6° and 120.6° with a 5° or higher change under 7.0 milliseconds.

POSSIBLE CAUSES

ENGINE TPS DTC'S PRESENT
 THROTTLE POSITION SENSOR
 TRANSMISSION CONTROL MODULE

| TEST | ACTION | APPLICABILITY |
|------|---|---------------|
| 1 | <p>NOTE: Low fluid level can be the cause of many Transmission problems. If the fluid level is low, locate and repair the leak, then check and adjust the fluid level per the Service Information.</p> <p>NOTE: Always perform diagnostics with a fully charged battery to avoid false symptoms.</p> <p>With the DRBIII®, read the engine DTC's. Check and repair all engine DTC's prior to performing Transmission Symptom Diagnostics.</p> <p>With the DRBIII®, read Transmission DTC's. Record all DTC's and 1 Trip Failures.</p> <p>NOTE: Diagnose 1 Trip Failures as a fully matured DTC.</p> <p>Using the wiring diagram/schematic as a guide, inspect the wiring and connectors. Repair as necessary.</p> <p>Perform the Shift Lever Position Test. If the test does not pass, refer to Symptom test for P0706 Check Shifter Signal.</p> <p>For Gear Ratio DTC's, check and record all CVI's.</p> <p>Most DTC's set on start up but some must be set by driving the vehicle such that all diagnostic monitors have run.</p> <p>NOTE: Verify flash level of Transmission Control Module. Some problems are corrected by software upgrades to the Transmission Control Module.</p> <p>NOTE: Check for applicable TSB's related to the symptom.</p> <p>Perform this procedure prior to Symptom diagnosis.</p> <p>Continue Go To 2</p> | All |
| 2 | <p>With the DRBIII®, check Engine DTC's.</p> <p>Are any Engine TPS related DTC's present?</p> <p>Yes → Refer to the Powertrain category and perform the appropriate symptom. Perform 42RLE TRANSMISSION VERIFICATION TEST - VER 1.</p> <p>No → Go To 3</p> | All |

P0124- THROTTLE POSITION SENSOR/APPS INTERMITTENT —
Continued

| TEST | ACTION | APPLICABILITY |
|------|--|---------------|
| 3 | Ignition On, Engine Not Running. With the DRBIII®, under Transmission Sensors, monitor the TPS voltage in the following step. Slowly open and close the throttle while checking for erratic voltage changes. Did the TPS voltage change smooth and consistent? Yes → Go To 4 No → Replace the Throttle Position Sensor per the Service Information. Perform 42RLE TRANSMISSION VERIFICATION TEST - VER 1. | All |
| 4 | Using the schematics as a guide, inspect the wiring and connectors. Repair as necessary. Pay particular attention to all power and ground circuits. If there are no possible causes remaining, view repair. Repair Replace the Transmission Control Module per the Service Information. WITH THE DRBIII® PERFORM QUICK LEARN. Perform 42RLE TRANSMISSION VERIFICATION TEST - VER 1. | All |

Symptom:**P0218-HIGH TEMPERATURE OPERATION ACTIVATED****When Monitored and Set Condition:****P0218-HIGH TEMPERATURE OPERATION ACTIVATED**

When Monitored: Whenever the engine is running.

Set Condition: Immediately when the Overheat shift schedule is activated 116 C (240 F) Transmission oil temp.

POSSIBLE CAUSES

ENGINE COOLING SYSTEM MALFUNCTION
TRANSMISSION OIL COOLER PLUGGED
HIGH TEMPERATURE OPERATIONS ACTIVATED

| TEST | ACTION | APPLICABILITY |
|------|--|---------------|
| 1 | <p>NOTE: Low fluid level can be the cause of many Transmission problems. If the fluid level is low, locate and repair the leak, then check and adjust the fluid level per the Service Information.</p> <p>NOTE: Always perform diagnostics with a fully charged battery to avoid false symptoms.</p> <p>With the DRBIII®, read the engine DTC's. Check and repair all engine DTC's prior to performing Transmission Symptom Diagnostics.</p> <p>With the DRBIII®, read Transmission DTC's. Record all DTC's and 1 Trip Failures.</p> <p>NOTE: Diagnose 1 Trip Failures as a fully matured DTC.</p> <p>Using the wiring diagram/schematic as a guide, inspect the wiring and connectors. Repair as necessary.</p> <p>Perform the Shift Lever Position Test. If the test does not pass, refer to Symptom test for P0706 Check Shifter Signal.</p> <p>For Gear Ratio DTC's, check and record all CVI's.</p> <p>Most DTC's set on start up but some must be set by driving the vehicle such that all diagnostic monitors have run.</p> <p>NOTE: Verify flash level of Transmission Control Module. Some problems are corrected by software upgrades to the Transmission Control Module.</p> <p>NOTE: Check for applicable TSB's related to the symptom.</p> <p>Perform this procedure prior to Symptom diagnosis.</p> <p style="text-align: center;">Continue Go To 2</p> | All |

P0218-HIGH TEMPERATURE OPERATION ACTIVATED — Continued

| TEST | ACTION | APPLICABILITY |
|------|--|---------------|
| 2 | <p>This DTC is an informational DTC designed to aid the Technician in diagnosing shift quality complaints. This DTC indicates that the Transmission has been operating in the "Overheat" shift schedule which may generate a customer complaint. The customer driving patterns may indicate the need for an additional Transmission Oil Cooler. With the DRBIII®, check the EATX EVENT DATA to help identify the conditions in which the DTC was set. Were there any problems found?</p> <p>Yes → Repair the cause of the Transmission Overheating per the Service Information. If indicated install an additional Transmission Oil Cooler. Perform 42RLE TRANSMISSION VERIFICATION TEST - VER 1.</p> <p>No → Go To 3</p> | All |
| 3 | <p>Perform Engine Cooling System diagnostics per the Service Information Is the Engine Cooling System functioning properly?</p> <p>Yes → Go To 4</p> <p>No → Repair the cause of the Engine Overheating. Refer to the Service Information for additional repair information. Perform 42RLE TRANSMISSION VERIFICATION TEST - VER 1.</p> | All |
| 4 | <p>If there are no possible causes remaining, view repair.</p> <p>Repair Flush or replace the Transmission Oil cooler as necessary per the Service Information. Perform 42RLE TRANSMISSION VERIFICATION TEST - VER 1.</p> | All |

Symptom:
P0562-LOW BATTERY VOLTAGE

When Monitored and Set Condition:

P0562-LOW BATTERY VOLTAGE

When Monitored: With the engine running and the TCM has closed the Transmission Control Relay.

Set Condition: If battery voltage at TCM Transmission Control Relay Output Sense circuit is less than 10.0 volts for 15 seconds. *This DTC generally indicates a gradually falling battery voltage or resistive connections to the TCM.

POSSIBLE CAUSES

- RELATED CHARGING SYSTEM DTCS
- INTERMITTENT WIRING AND CONNECTORS
- FUSED B+ CIRCUIT OPEN OR HIGH RESISTANCE
- GROUND CIRCUIT OPEN OR HIGH RESISTANCE
- TRANS CONTROL RELAY OUTPUT TO TCM OPEN OR HIGH RESISTANCE
- TRANSMISSION CONTROL RELAY OPEN OR HIGH RESISTANCE
- TRANSMISSION CONTROL MODULE

| TEST | ACTION | APPLICABILITY |
|------|--|---------------|
| 1 | <p>NOTE: Low fluid level can be the cause of many Transmission problems. If the fluid level is low, locate and repair the leak, then check and adjust the fluid level per the Service Information.</p> <p>NOTE: Always perform diagnostics with a fully charged battery to avoid false symptoms.</p> <p>With the DRBIII®, read the engine DTC's. Check and repair all engine DTC's prior to performing Transmission Symptom Diagnostics.</p> <p>With the DRBIII®, read Transmission DTC's. Record all DTC's and 1 Trip Failures.</p> <p>NOTE: Diagnose 1 Trip Failures as a fully matured DTC.</p> <p>Using the wiring diagram/schematic as a guide, inspect the wiring and connectors. Repair as necessary.</p> <p>Perform the Shift Lever Position Test. If the test does not pass, refer to Symptom test for P0706 Check Shifter Signal.</p> <p>For Gear Ratio DTC's, check and record all CVI's.</p> <p>Most DTC's set on start up but some must be set by driving the vehicle such that all diagnostic monitors have run.</p> <p>NOTE: Verify flash level of Transmission Control Module. Some problems are corrected by software upgrades to the Transmission Control Module.</p> <p>NOTE: Check for applicable TSB's related to the symptom.</p> <p>Perform this procedure prior to Symptom diagnosis.</p> <p style="text-align: center;">Continue Go To 2</p> | All |

P0562-LOW BATTERY VOLTAGE — Continued

| TEST | ACTION | APPLICABILITY |
|------|---|---------------|
| 2 | <p>With the DRBIII®, read the PCM DTC's. Are there any Charging System related DTC's stored in the PCM?</p> <p>Yes → Refer to the Charging System category and repair any PCM Charging System DTC's first. NOTE: After repairing the PCM charging system DTC's, perform the Transmission Verification test to verify the transmission was not damaged. Perform 42RLE TRANSMISSION VERIFICATION TEST - VER 1.</p> <p>No → Go To 3</p> | All |
| 3 | <p>NOTE: Generator, battery, and charging system must be fully functional before performing this test. With the DRBIII®, read Transmission DTC's. With the DRBIII®, Check the STARTS SINCE SET counter for P0562. Note: This counter only applies to the last DTC set. Is the Starts Since Set counter for P0562 set at 0?</p> <p>Yes → Go To 4</p> <p>No → Go To 9</p> | All |
| 4 | <p>Turn the ignition off to the lock position. Disconnect the TCM harness connector. Note: Check connectors - Clean/repair as necessary. Using a 12-volt test light connected to 12-volts, check the ground circuits in the TCM harness connector. NOTE: The test light must illuminate brightly. Compare the brightness to that of a direct connection to the battery. Does the test light illuminate brightly for all the ground circuits?</p> <p>Yes → Go To 5</p> <p>No → Repair the Ground circuit(s) for an open or high resistance. Perform 42RLE TRANSMISSION VERIFICATION TEST - VER 1.</p> | All |
| 5 | <p>Turn the ignition off to the lock position. Disconnect the TCM harness connector. Remove the Transmission Control Relay. Note: Check connectors - Clean/repair as necessary. Connect a jumper wire between the Fused B+ circuit and the Transmission Control Relay Output in the Transmission Control Relay connector in the PDC. Ignition on, engine not running. Using a 12-volt test light connected to ground, check the Fused B+ circuit in the TCM harness connector. NOTE: The test light must illuminate brightly. Compare the brightness to that of a direct connection to the battery. Does the test light illuminate brightly?</p> <p>Yes → Go To 6</p> <p>No → Repair the Fused B+ circuit for an open or high resistance. If the fuse is open make sure to check for a short to ground. Perform 42RLE TRANSMISSION VERIFICATION TEST - VER 1.</p> | All |

P0562-LOW BATTERY VOLTAGE — Continued

| TEST | ACTION | APPLICABILITY |
|------|---|---------------|
| 6 | <p>Turn the ignition off to the lock position. Disconnect the TCM harness connector. Remove the Transmission Control Relay from the PDC. Note: Check connectors - Clean/repair as necessary. Connect a jumper wire between the Fused B+ circuit and the Transmission Control Relay Output circuit in the Transmission Control Relay connector in the PDC. Ignition on, engine not running. Using a 12-volt test light connected to ground, check both Transmission Control Relay Output circuits in the TCM harness connector. NOTE: The test light must illuminate brightly. Compare the brightness to that of a direct connection to the battery. Does the test light illuminate brightly?</p> <p style="padding-left: 40px;">Yes → Go To 7</p> <p style="padding-left: 40px;">No → Repair the Transmission Control Relay Output circuit for an open or high resistance. Perform 42RLE TRANSMISSION VERIFICATION TEST - VER 1.</p> | All |
| 7 | <p>Turn the ignition off to the lock position. Install a substitute Relay in place of the Transmission Control Relay. Start the engine. Using a voltmeter, measure the battery voltage. With the DRBIII®, monitor the Transmission Switched Battery Voltage. Compare the DRBIII® Transmission Switched Battery voltage to the actual battery voltage. Is the DRBIII® voltage within 2.0 volts of the battery voltage?</p> <p style="padding-left: 40px;">Yes → Replace the Transmission Control Relay. Perform 42RLE TRANSMISSION VERIFICATION TEST - VER 1.</p> <p style="padding-left: 40px;">No → Go To 8</p> | All |
| 8 | <p>Using the schematics as a guide, inspect the wiring and connectors. Repair as necessary. Pay particular attention to all power and ground circuits. If there are no possible causes remaining, view repair.</p> <p style="padding-left: 40px;">Repair</p> <p style="padding-left: 80px;">Replace the Transmission Control Module per the Service Information. WITH THE DRBIII® PERFORM QUICK LEARN. Perform 42RLE TRANSMISSION VERIFICATION TEST - VER 1.</p> | All |
| 9 | <p>The conditions necessary to set this DTC are not present at this time. Using the schematics as a guide, inspect the wiring and connectors specific to this circuit. Wiggle the wiring while checking for shorts and open circuits. Were there any problems found?</p> <p style="padding-left: 40px;">Yes → Repair as necessary. Perform 42RLE TRANSMISSION VERIFICATION TEST - VER 1.</p> <p style="padding-left: 40px;">No → Test Complete.</p> | All |

Symptom:

P0604-INTERNAL TCM

When Monitored and Set Condition:

P0604-INTERNAL TCM

When Monitored:

Set Condition: The TCM is reporting internal errors and must be replaced.

POSSIBLE CAUSES

TCM - INTERNAL ERROR

| TEST | ACTION | APPLICABILITY |
|------|---|---------------|
| 1 | Using the schematics as a guide, inspect the wiring and connectors. Repair as necessary. Pay particular attention to all power and ground circuits. If there are no possible causes remaining, view repair. Repair Replace the Transmission Control Module per the Service Information. WITH THE DRBIII® PERFORM QUICK LEARN. Perform 42RLE TRANSMISSION VERIFICATION TEST - VER 1. | All |

Symptom:
P0605-INTERNAL TCM

When Monitored and Set Condition:

P0605-INTERNAL TCM

When Monitored:

Set Condition: The TCM is reporting internal errors and must be replaced.

POSSIBLE CAUSES

TCM - INTERNAL ERROR

| TEST | ACTION | APPLICABILITY |
|------|---|---------------|
| 1 | Using the schematics as a guide, inspect the wiring and connectors. Repair as necessary. Pay particular attention to all power and ground circuits. If there are no possible causes remaining, view repair. Repair Replace the Transmission Control Module per the Service Information. WITH THE DRBIII® PERFORM QUICK LEARN. Perform 42RLE TRANSMISSION VERIFICATION TEST - VER 1. | All |

Symptom:
P0613-INTERNAL TCM

When Monitored and Set Condition:

P0613-INTERNAL TCM

When Monitored:

Set Condition: The TCM is reporting internal errors and must be replaced.

POSSIBLE CAUSES

TCM - INTERNAL ERROR

| TEST | ACTION | APPLICABILITY |
|------|---|---------------|
| 1 | <p>NOTE: Make sure this DTC is set in the TCM before making repair. Using the schematics as a guide, inspect the wiring and connectors. Repair as necessary. Pay particular attention to all power and ground circuits. If there are no possible causes remaining, view repair.</p> <p>Repair</p> <p>Replace the Transmission Control Module per the Service Information. WITH THE DRBIII® PERFORM QUICK LEARN. Perform 42RLE TRANSMISSION VERIFICATION TEST - VER 1.</p> | All |

Symptom:**P0706-CHECK SHIFTER SIGNAL****When Monitored and Set Condition:****P0706-CHECK SHIFTER SIGNAL**

When Monitored: Continuously with the ignition key on.

Set Condition: 3 occurrences in one key start of an invalid PRNDL code which lasts for more than 0.1 second.

POSSIBLE CAUSES

CONDITION P0706 PRESENT
TRS T1 SENSE CIRCUIT OPEN
TRS T3 SENSE CIRCUIT OPEN
TRS T41 SENSE CIRCUIT OPEN
TRS T42 SENSE CIRCUIT OPEN
TRS T1 SENSE CIRCUIT SHORT TO GROUND
TRS T3 SENSE CIRCUIT SHORT TO GROUND
TRS T41 SENSE CIRCUIT SHORT TO GROUND
TRS T42 SENSE CIRCUIT SHORT TO GROUND
TRS T1 SENSE CIRCUIT SHORT TO VOLTAGE
TRS T3 SENSE CIRCUIT SHORT TO VOLTAGE
TRS T41 SENSE CIRCUIT SHORT TO VOLTAGE
TRS T42 SENSE CIRCUIT SHORT TO VOLTAGE
TRANSMISSION RANGE SENSOR
TRANSMISSION CONTROL MODULE
INTERMITTENT WIRING AND CONNECTORS

P0706-CHECK SHIFTER SIGNAL — Continued

| TEST | ACTION | APPLICABILITY |
|------|--|---------------|
| 1 | <p>NOTE: Low fluid level can be the cause of many Transmission problems. If the fluid level is low, locate and repair the leak, then check and adjust the fluid level per the Service Information.</p> <p>NOTE: Always perform diagnostics with a fully charged battery to avoid false symptoms.</p> <p>With the DRBIII®, read the engine DTC's. Check and repair all engine DTC's prior to performing Transmission Symptom Diagnostics.</p> <p>With the DRBIII®, read Transmission DTC's. Record all DTC's and 1 Trip Failures.</p> <p>NOTE: Diagnose 1 Trip Failures as a fully matured DTC.</p> <p>Using the wiring diagram/schematic as a guide, inspect the wiring and connectors. Repair as necessary.</p> <p>Perform the Shift Lever Position Test. If the test does not pass, refer to Symptom test for P0706 Check Shifter Signal.</p> <p>For Gear Ratio DTC's, check and record all CVT's.</p> <p>Most DTC's set on start up but some must be set by driving the vehicle such that all diagnostic monitors have run.</p> <p>NOTE: Verify flash level of Transmission Control Module. Some problems are corrected by software upgrades to the Transmission Control Module.</p> <p>NOTE: Check for applicable TSB's related to the symptom.</p> <p>Perform this procedure prior to Symptom diagnosis.</p> <p style="text-align: center;">Continue Go To 2</p> | All |
| 2 | <p>Using the DRBIII®, perform the Shift Lever Position Test.</p> <p>Select the test outcome from the following:</p> <p style="padding-left: 40px;">Test passes Go To 3</p> <p style="padding-left: 40px;">Test fails with DTC Go To 4</p> <p style="padding-left: 40px;">Test fails without DTC Adjust the shift linkage per the Service Information. Perform 42RLE TRANSMISSION VERIFICATION TEST - VER 1.</p> | All |
| 3 | <p>The conditions necessary to set this DTC are not present at this time.</p> <p>Using the schematics as a guide, inspect the wiring and connectors specific to this circuit.</p> <p>Wiggle the wiring while checking for shorts and open circuits.</p> <p>With the DRBIII®, check the EATX EVENT DATA to help identify the conditions in which the DTC was set.</p> <p>Were there any problems found?</p> <p style="padding-left: 40px;">Yes → Repair as necessary. Perform 42RLE TRANSMISSION VERIFICATION TEST - VER 1.</p> <p style="padding-left: 40px;">No → Test Complete.</p> | All |

P0706-CHECK SHIFTER SIGNAL — Continued

| TEST | ACTION | APPLICABILITY |
|------|---|---------------|
| 4 | <p>Turn the ignition off to the lock position. CAUTION: Remove the Starter Relay from the PDC. This will prevent the vehicle from being started in gear. Install the Transmission Simulator, Miller tool #8333 and the Electronic Transmission Adapter kit 8333-1. Ignition on, engine not running. With the DRBIII®, perform the Shift Lever Position Test. When the DRBIII® instructs you to put the Gear Selector in a particular position, you must do so using the Transmission Simulator. The LED for the gear position in question must be illuminated prior to hitting "enter" on the DRBIII®. Did the test pass?</p> <p style="padding-left: 40px;">Yes → Go To 5</p> <p style="padding-left: 40px;">No → Go To 6</p> <p>NOTE: Disconnect the Transmission Simulator and reconnect all the harness connectors.</p> | All |
| 5 | <p>If there are no possible causes remaining, view repair.</p> <p style="padding-left: 40px;">Repair</p> <p style="padding-left: 80px;">Replace the Transmission Range Sensor per the Service Information. Perform 42RLE TRANSMISSION VERIFICATION TEST - VER 1.</p> | All |
| 6 | <p>Ignition on, engine not running. With the DRBIII® in Inputs/Outputs, read the TRS Sense circuits C1 thru C4. Move the shift lever thru all gear positions, pausing momentarily in each gear position. Watch for one of the circuits to not change state. Pick the one that did not change state.</p> <p style="padding-left: 40px;">TRS T1 sense (C4) Go To 7</p> <p style="padding-left: 40px;">TRS T3 sense (C3) Go To 10</p> <p style="padding-left: 40px;">TRS T41 sense (C1) Go To 13</p> <p style="padding-left: 40px;">TRS T42 sense (C2) Go To 16</p> | All |
| 7 | <p>Turn the ignition off to the lock position. Disconnect the TRS harness connector. Disconnect the TCM harness connector. Note: Check connectors - Clean/repair as necessary. Measure the resistance of the TRS T1 Sense circuit from the TCM harness connector to the TRS harness connector. Is the resistance above 5.0 ohms?</p> <p style="padding-left: 40px;">Yes → Repair the TRS T1 Sense circuit for an open. Perform 42RLE TRANSMISSION VERIFICATION TEST - VER 1.</p> <p style="padding-left: 40px;">No → Go To 8</p> | All |

P0706-CHECK SHIFTER SIGNAL — Continued

| TEST | ACTION | APPLICABILITY |
|------|---|---------------|
| 8 | Turn the ignition off to the lock position. Disconnect the TRS harness connector. Disconnect the TCM harness connector. Note: Check connectors - Clean/repair as necessary. Measure the resistance between ground and the TRS T1 circuit in the TCM harness connector. Is the resistance below 5.0 ohms? Yes → Repair the TRS T1 Sense circuit for a short to ground. Perform 42RLE TRANSMISSION VERIFICATION TEST - VER 1. No → Go To 9 | All |
| 9 | Turn the ignition off to the lock position. Disconnect the TRS harness connector. Disconnect the TCM harness connector. Remove the Transmission Control Relay from the PDC. Note: Check connectors - Clean/repair as necessary. Connect a jumper wire between the Fused B+ circuit and the Transmission Control Relay Output circuit in the Transmission Control Relay connector in the PDC. Ignition on, engine not running. Measure the voltage of the TRS T1 Sense circuit. Is the voltage above 0.5 volt? Yes → Repair the TRS T1 Sense circuit for a short to voltage. Perform 42RLE TRANSMISSION VERIFICATION TEST - VER 1. No → Go To 19 | All |
| 10 | Turn the ignition off to the lock position. Disconnect the TRS harness connector. Disconnect the TCM harness connector. Note: Check connectors - Clean/repair as necessary. Measure the resistance of the TRS T3 Sense circuit from the TCM harness connector to the TRS harness connector. Is the resistance above 5.0 ohms? Yes → Repair the TRS T3 Sense circuit for an open. Perform 42RLE TRANSMISSION VERIFICATION TEST - VER 1. No → Go To 11 | All |
| 11 | Turn the ignition off to the lock position. Disconnect the TRS harness connector. Disconnect the TCM harness connector. Note: Check connectors - Clean/repair as necessary. Measure the resistance between ground and the TRS T3 Sense circuit in the TCM harness connector. Is the resistance below 5.0 ohms? Yes → Repair the TRS T3 Sense circuit for a short to ground. Perform 42RLE TRANSMISSION VERIFICATION TEST - VER 1. No → Go To 12 | All |

P0706-CHECK SHIFTER SIGNAL — Continued

| TEST | ACTION | APPLICABILITY |
|------|---|---------------|
| 12 | Turn the ignition off to the lock position. Disconnect the TRS harness connector. Disconnect the TCM harness connector. Remove the Transmission Control Relay from the PDC. Note: Check connectors - Clean/repair as necessary. Connect a jumper wire between the Fused B+ circuit and the Transmission Control Relay Output circuit in the Transmission Control Relay connector in the PCM. Ignition on, engine not running. Measure the voltage of the TRS T3 Sense circuit. Is the voltage above 0.5 volt? Yes → Repair the TRS T3 Sense circuit for a short to voltage. Perform 42RLE TRANSMISSION VERIFICATION TEST - VER 1. No → Go To 19 | All |
| 13 | Turn the ignition off to the lock position. Disconnect the TRS harness connector. Disconnect the TCM harness connector. Note: Check connectors - Clean/repair as necessary. Measure the resistance of the TRS T41 Sense circuit from the TCM connector to the TRS connector. Is the resistance above 5.0 ohms? Yes → Repair the TRS T41 Sense circuit for an open. Perform 42RLE TRANSMISSION VERIFICATION TEST - VER 1. No → Go To 14 | All |
| 14 | Turn the ignition off to the lock position. Disconnect the TRS harness connector. Disconnect the TCM harness connector. Note: Check connectors - Clean/repair as necessary. Measure the resistance between ground and the TRS T41 Sense circuit in the TCM harness connector. Is the resistance below 5.0 ohms? Yes → Repair the TRS T41 Sense circuit for a short to ground. Perform 42RLE TRANSMISSION VERIFICATION TEST - VER 1. No → Go To 15 | All |
| 15 | Turn the ignition off to the lock position. Disconnect the TRS harness connector. Disconnect the TCM harness connector. Remove the Transmission Control Relay from the PDC. Note: Check connectors - Clean/repair as necessary. Connect a jumper wire between the Fused B+ circuit and the Transmission Control Relay Output circuit in the Transmission Control Relay connector in the PDC. Ignition on, engine not running. Measure the voltage of the TRS T41 Sense circuit. Is the voltage above 0.5 volt? Yes → Repair the TRS T41 Sense circuit for a short to voltage. Perform 42RLE TRANSMISSION VERIFICATION TEST - VER 1. No → Go To 19 | All |

P0706-CHECK SHIFTER SIGNAL — Continued

| TEST | ACTION | APPLICABILITY |
|------|---|---------------|
| 16 | Turn the ignition off to the lock position. Disconnect the TRS harness connector. Disconnect the TCM harness connector. Note: Check connectors - Clean/repair as necessary. Measure the resistance of the TRS T42 Sense circuit from the TCM harness connector to the TRS harness connector. Is the resistance above 5.0 ohms? Yes → Repair the TRS T42 Sense circuit for an open. Perform 42RLE TRANSMISSION VERIFICATION TEST - VER 1. No → Go To 17 | All |
| 17 | Turn the ignition off to the lock position. Disconnect the TRS harness connector. Disconnect the TCM harness connector. Note: Check connectors - Clean/repair as necessary. Measure the resistance between ground and the TRS T42 Sense circuit in the TCM harness connector. Is the resistance below 5.0 ohms? Yes → Repair the TRS T42 Sense circuit for a short to ground. Perform 42RLE TRANSMISSION VERIFICATION TEST - VER 1. No → Go To 18 | All |
| 18 | Turn the ignition off to the lock position. Disconnect the TRS harness connector. Disconnect the TCM harness connector. Remove the Transmission Control Relay from the PDC. Note: Check connectors - Clean/repair as necessary. Connect a jumper wire between the Fused B+ circuit and the Transmission Control Relay Output circuit in the Transmission Control Relay connector in the PDC. Ignition on, engine not running. Measure the voltage of the TRS T42 Sense circuit. Is the voltage above 0.5 volt? Yes → Repair the TRS T42 Sense circuit for a short to voltage. Perform 42RLE TRANSMISSION VERIFICATION TEST - VER 1. No → Go To 19 | All |
| 19 | Using the schematics as a guide, inspect the wiring and connectors. Repair as necessary. Pay particular attention to all power and ground circuits. If there are no possible causes remaining, view repair. Repair Replace the Transmission Control Module per the Service Information. WITH THE DRBIII® PERFORM QUICK LEARN. Perform 42RLE TRANSMISSION VERIFICATION TEST - VER 1. | All |

Symptom:

P0711-TRANSMISSION TEMPERATURE SENSOR PERFORMANCE

When Monitored and Set Condition:

P0711-TRANSMISSION TEMPERATURE SENSOR PERFORMANCE

When Monitored: Continuously with the ignition on and engine running.

Set Condition: This DTC will set when the desired transmission temperature does not reach a normal operating temperature within a given time frame. Time is variable due to ambient temperature. Approximate times are starting temperature to warm up time: (-40° F / -40° C - 35 min) (-20° F / -28° C - 25 min) (20° F / -6.6° C - 20 min) (60° F / 15.5 ° C - 10 min)

POSSIBLE CAUSES

RELATED DTC'S PRESENT
 TRANSMISSION TEMPERATURE SENSOR
 TRANSMISSION CONTROL MODULE
 INTERMITTENT WIRING AND CONNECTORS

| TEST | ACTION | APPLICABILITY |
|------|---|---------------|
| 1 | <p>NOTE: Low fluid level can be the cause of many Transmission problems. If the fluid level is low, locate and repair the leak, then check and adjust the fluid level per the Service Information.</p> <p>NOTE: Always perform diagnostics with a fully charged battery to avoid false symptoms.</p> <p>With the DRBIII®, read the engine DTC's. Check and repair all engine DTC's prior to performing Transmission Symptom Diagnostics.</p> <p>With the DRBIII®, read Transmission DTC's. Record all DTC's and 1 Trip Failures.</p> <p>NOTE: Diagnose 1 Trip Failures as a fully matured DTC.</p> <p>Using the wiring diagram/schematic as a guide, inspect the wiring and connectors. Repair as necessary.</p> <p>Perform the Shift Lever Position Test. If the test does not pass, refer to Symptom test for P0706 Check Shifter Signal.</p> <p>For Gear Ratio DTC's, check and record all CVI's.</p> <p>Most DTC's set on start up but some must be set by driving the vehicle such that all diagnostic monitors have run.</p> <p>NOTE: Verify flash level of Transmission Control Module. Some problems are corrected by software upgrades to the Transmission Control Module.</p> <p>NOTE: Check for applicable TSB's related to the symptom.</p> <p>Perform this procedure prior to Symptom diagnosis.</p> <p>Continue Go To 2</p> | All |

P0711-TRANSMISSION TEMPERATURE SENSOR PERFORMANCE — Continued

| TEST | ACTION | APPLICABILITY |
|------|---|---------------|
| 2 | With the DRBIII®, check Transmission DTC's. Are there any other Transmission Temperature Sensor related DTCs present? Yes → Refer to the Transmission category and perform the appropriate symptom. Perform 42RLE TRANSMISSION VERIFICATION TEST - VER 1. No → Go To 3 | All |
| 3 | With the DRBIII®, Check the STARTS SINCE SET counter for P0711. NOTE: This counter only applies to the last DTC set. Is the STARTS SINCE SET counter 2 or less? Yes → Go To 4 No → Go To 7 | All |
| 4 | Turn the ignition off to the lock position. Remove the Starter Relay. NOTE: Failure to remove Starter Relay can cause a Transmission - No Response condition. Install the Transmission Simulator, Miller tool #8333 and the Electronic Transmission Adapter kit 8333-1. Note: Check connectors - Clean/repair as necessary. Ignition on, engine not running. With the Transmission Simulator, turn the Input/Output switch to OFF. With the DRBIII®, monitor the TRANS TEMP VOLTS while turning the Thermistor Voltage switch to all three positions on the Transmission Simulator. Compare the DRBIII® readings with the numbers listed on the Transmission Simulator. Do the readings on the Transmission Simulator match the DRBIII® readings ± 0.2 volts? Yes → Go To 5 No → Go To 6 | All |
| 5 | If there are no possible causes remaining, view repair. Repair Replace Transmission Solenoid/TRS Assembly per the Service Information. Perform 42RLE TRANSMISSION VERIFICATION TEST - VER 1. | All |
| 6 | Using the schematics as a guide, inspect the wiring and connectors. Repair as necessary. Pay particular attention to all power and ground circuits. If there are no possible causes remaining, view repair. Repair Replace the Transmission Control Module per the Service Information. WITH THE DRBIII® PERFORM QUICK LEARN. Perform 42RLE TRANSMISSION VERIFICATION TEST - VER 1. | All |

P0711-TRANSMISSION TEMPERATURE SENSOR PERFORMANCE — Continued

| TEST | ACTION | APPLICABILITY |
|------|--|---------------|
| 7 | <p>The conditions necessary to set this DTC are not present at this time. Using the schematics as a guide, inspect the wiring and connectors specific to this circuit. Wiggle the wires while checking for shorts and open circuits. With the DRBIII®, check the EATX EVENT DATA to help identify the conditions in which the DTC was set. Were there any problems found?</p> <p>Yes → Repair as necessary. Perform 42RLE TRANSMISSION VERIFICATION TEST - VER 1.</p> <p>No → Test Complete.</p> | All |

Symptom:

P0712-TRANSMISSION TEMPERATURE SENSOR LOW

When Monitored and Set Condition:

P0712-TRANSMISSION TEMPERATURE SENSOR LOW

When Monitored: Continuously with the ignition on and engine running.

Set Condition: The DTC will set when the monitored Temperature Sensor voltage drops below 0.078 volts for the period of 0.45 seconds.

POSSIBLE CAUSES

RELATED DTC'S PRESENT

TRANSMISSION TEMPERATURE SENSOR SIGNAL CIRCUIT SHORT TO GROUND

TRANSMISSION TEMPERATURE SENSOR

TRANSMISSION CONTROL MODULE

INTERMITTENT WIRING AND CONNECTORS

| TEST | ACTION | APPLICABILITY |
|------|--|---------------|
| 1 | <p>NOTE: Low fluid level can be the cause of many Transmission problems. If the fluid level is low, locate and repair the leak, then check and adjust the fluid level per the Service Information.</p> <p>NOTE: Always perform diagnostics with a fully charged battery to avoid false symptoms.</p> <p>With the DRBIII®, read the engine DTC's. Check and repair all engine DTC's prior to performing Transmission Symptom Diagnostics.</p> <p>With the DRBIII®, read Transmission DTC's. Record all DTC's and 1 Trip Failures.</p> <p>NOTE: Diagnose 1 Trip Failures as a fully matured DTC.</p> <p>Using the wiring diagram/schematic as a guide, inspect the wiring and connectors. Repair as necessary.</p> <p>Perform the Shift Lever Position Test. If the test does not pass, refer to Symptom test for P0706 Check Shifter Signal.</p> <p>For Gear Ratio DTC's, check and record all CVI's.</p> <p>Most DTC's set on start up but some must be set by driving the vehicle such that all diagnostic monitors have run.</p> <p>NOTE: Verify flash level of Transmission Control Module. Some problems are corrected by software upgrades to the Transmission Control Module.</p> <p>NOTE: Check for applicable TSB's related to the symptom.</p> <p>Perform this procedure prior to Symptom diagnosis.</p> <p>Continue Go To 2</p> | All |
| 2 | <p>With the DRBIII®, check Transmission DTC's.</p> <p>Are there any Speed Sensor DTCs present?</p> <p>Yes → Refer to the Transmission category and perform the appropriate symptom.</p> <p>Perform 42RLE TRANSMISSION VERIFICATION TEST - VER 1.</p> <p>No → Go To 3</p> | All |

P0712-TRANSMISSION TEMPERATURE SENSOR LOW — Continued

| TEST | ACTION | APPLICABILITY |
|------|--|---------------|
| 3 | <p>With the DRBIII®, Check the STARTS SINCE SET counter for P0712. NOTE: This counter only applies to the last DTC set. Is the STARTS SINCE SET counter 2 or less?</p> <p style="padding-left: 40px;">Yes → Go To 4</p> <p style="padding-left: 40px;">No → Go To 8</p> | All |
| 4 | <p>Turn the ignition off to the lock position. Remove the Starter Relay. NOTE: Failure to remove Starter Relay can cause a Transmission - No Response condition. Install the Transmission Simulator, Miller tool #8333 and the Electronic Transmission Adapter kit 8333-1. Note: Check connectors - Clean/repair as necessary. Ignition on, engine not running. With the Transmission Simulator, turn the Input/Output switch to OFF. With the DRBIII®, monitor the TRANS TEMP VOLTS while turning the Thermistor Voltage switch to all three positions on the Transmission Simulator. Compare the DRBIII® readings with the numbers listed on the Transmission Simulator. Do the readings on the Transmission Simulator match the DRBIII® readings ± 0.2 volts?</p> <p style="padding-left: 40px;">Yes → Go To 5</p> <p style="padding-left: 40px;">No → Go To 6</p> | All |
| 5 | <p>If there are no possible causes remaining, view repair.</p> <p style="padding-left: 40px;">Repair</p> <p style="padding-left: 80px;">Replace Transmission Solenoid/TRS Assembly per the Service Information. Perform 42RLE TRANSMISSION VERIFICATION TEST - VER 1.</p> | All |
| 6 | <p>Turn the ignition off to the lock position. Disconnect the TCM harness connector. Disconnect the Transmission Solenoid/TRS Assembly harness connector. Note: Check connectors - Clean/repair as necessary. Measure the resistance between ground and the Transmission Temperature Sensor Signal circuit. Is the resistance below 5.0 ohms?</p> <p style="padding-left: 40px;">Yes → Repair the Transmission Temperature Sensor Signal circuit for a short to ground. Perform 42RLE TRANSMISSION VERIFICATION TEST - VER 1.</p> <p style="padding-left: 40px;">No → Go To 7</p> | All |
| 7 | <p>Using the schematics as a guide, inspect the wiring and connectors. Repair as necessary. Pay particular attention to all power and ground circuits. If there are no possible causes remaining, view repair.</p> <p style="padding-left: 40px;">Repair</p> <p style="padding-left: 80px;">Replace the Transmission Control Module per the Service Information. WITH THE DRBIII® PERFORM QUICK LEARN. Perform 42RLE TRANSMISSION VERIFICATION TEST - VER 1.</p> | All |

P0712-TRANSMISSION TEMPERATURE SENSOR LOW — Continued

| TEST | ACTION | APPLICABILITY |
|------|---|---------------|
| 8 | <p>The conditions necessary to set this DTC are not present at this time. Using the schematics as a guide, inspect the wiring and connectors specific to this circuit. Wiggle the wires while checking for shorts and open circuits. With the DRBIII®, check the EATX EVENT DATA to help identify the conditions in which the DTC was set. Were there any problems found?</p> <p style="padding-left: 40px;">Yes → Repair as necessary. Perform 42RLE TRANSMISSION VERIFICATION TEST - VER 1.</p> <p style="padding-left: 40px;">No → Test Complete.</p> | All |

Symptom:**P0713-TRANSMISSION TEMPERATURE SENSOR HIGH****When Monitored and Set Condition:****P0713-TRANSMISSION TEMPERATURE SENSOR HIGH**

When Monitored: Continuously with the ignition on and engine running.

Set Condition: The DTC will set when the monitored Temperature Sensor voltage rises above 4.94 volts for the period of 0.45 seconds.

POSSIBLE CAUSES

TRANSMISSION TEMPERATURE SENSOR SIGNAL CIRCUIT OPEN
 TRANSMISSION TEMPERATURE SENSOR SIGNAL CIRCUIT SHORT TO VOLTAGE
 TRANSMISSION TEMPERATURE SENSOR
 TRANSMISSION CONTROL MODULE
 INTERMITTENT WIRING AND CONNECTORS

| TEST | ACTION | APPLICABILITY |
|------|--|---------------|
| 1 | <p>NOTE: Low fluid level can be the cause of many Transmission problems. If the fluid level is low, locate and repair the leak, then check and adjust the fluid level per the Service Information.</p> <p>NOTE: Always perform diagnostics with a fully charged battery to avoid false symptoms.</p> <p>With the DRBIII®, read the engine DTC's. Check and repair all engine DTC's prior to performing Transmission Symptom Diagnostics.</p> <p>With the DRBIII®, read Transmission DTC's. Record all DTC's and 1 Trip Failures.</p> <p>NOTE: Diagnose 1 Trip Failures as a fully matured DTC.</p> <p>Using the wiring diagram/schematic as a guide, inspect the wiring and connectors. Repair as necessary.</p> <p>Perform the Shift Lever Position Test. If the test does not pass, refer to Symptom test for P0706 Check Shifter Signal.</p> <p>For Gear Ratio DTC's, check and record all CVI's.</p> <p>Most DTC's set on start up but some must be set by driving the vehicle such that all diagnostic monitors have run.</p> <p>NOTE: Verify flash level of Transmission Control Module. Some problems are corrected by software upgrades to the Transmission Control Module.</p> <p>NOTE: Check for applicable TSB's related to the symptom.</p> <p>Perform this procedure prior to Symptom diagnosis.</p> <p>Continue Go To 2</p> | All |
| 2 | <p>With the DRBIII®, Check the STARTS SINCE SET counter for P0713.</p> <p>NOTE: This counter only applies to the last DTC set.</p> <p>Is the STARTS SINCE SET counter 2 or less?</p> <p>Yes → Go To 3 No → Go To 8</p> | All |

P0713-TRANSMISSION TEMPERATURE SENSOR HIGH — Continued

| TEST | ACTION | APPLICABILITY |
|------|--|---------------|
| 3 | <p>Turn the ignition off to the lock position. Remove the Starter Relay. NOTE: Failure to remove Starter Relay can cause a Transmission - No Response condition. Install the Transmission Simulator, Miller tool #8333 and the Electronic Transmission Adapter kit 8333-1. Note: Check connectors - Clean/repair as necessary. Ignition on, engine not running. With the Transmission Simulator, turn the Input/Output switch to OFF. With the DRBIII®, monitor the TRANS TEMP VOLTS while turning the Thermistor Voltage switch to all three positions on the Transmission Simulator. Compare the DRBIII® readings with the numbers listed on the Transmission Simulator. Do the readings on the Transmission Simulator match the DRBIII® readings ± 0.2 volts?</p> <p style="padding-left: 40px;">Yes → Go To 4 No → Go To 5</p> | All |
| 4 | <p>If there are no possible causes remaining, view repair.</p> <p style="padding-left: 40px;">Repair Replace Transmission Solenoid/TRS Assembly per the Service Information. Perform 42RLE TRANSMISSION VERIFICATION TEST - VER 1.</p> | All |
| 5 | <p>Turn the ignition off to the lock position. Disconnect the TCM harness connector. Disconnect the Transmission Solenoid /TRS Assembly harness connector Note: Check connectors - Clean/repair as necessary. Measure the resistance of the Transmission Temperature Sensor Signal circuit from the TCM harness connector to the Transmission Solenoid/TRS Assembly harness connector. Is the resistance above 5.0 ohms?</p> <p style="padding-left: 40px;">Yes → Repair the Transmission Temperature Sensor Signal circuit for an open. Perform 42RLE TRANSMISSION VERIFICATION TEST - VER 1. No → Go To 6</p> | All |
| 6 | <p>Turn the ignition off to the lock position. Disconnect the TCM harness connector. Remove the Transmission Control Relay. Note: Check connectors - Clean/repair as necessary. Connect a jumper wire between the Fused B+ circuit and the Transmission Control Relay Output circuit in the Transmission Control Relay connector. Ignition on, engine not running. Measure the voltage of the Transmission Temperature Sensor Signal circuit in the TCM harness connector. Is the voltage above 0.5 volts?</p> <p style="padding-left: 40px;">Yes → Repair the Transmission Temperature Sensor Signal circuit for a short to voltage. Perform 42RLE TRANSMISSION VERIFICATION TEST - VER 1. No → Go To 7</p> | All |

P0713-TRANSMISSION TEMPERATURE SENSOR HIGH — Continued

| TEST | ACTION | APPLICABILITY |
|------|--|---------------|
| 7 | <p>Using the schematics as a guide, inspect the wiring and connectors. Repair as necessary. Pay particular attention to all power and ground circuits. If there are no possible causes remaining, view repair.</p> <p>Repair</p> <p>Replace the Transmission Control Module per the Service information. WITH THE DRBIII® PERFORM QUICK LEARN. Perform 42RLE TRANSMISSION VERIFICATION TEST - VER 1.</p> | All |
| 8 | <p>The conditions necessary to set this DTC are not present at this time. Using the schematics as a guide, inspect the wiring and connectors specific to this circuit. Wiggle the wires while checking for shorts and open circuits. With the DRBIII®, check the EATX EVENT DATA to help identify the conditions in which the DTC was set. Were there any problems found?</p> <p>Yes → Repair as necessary. Perform 42RLE TRANSMISSION VERIFICATION TEST - VER 1.</p> <p>No → Test Complete.</p> | All |

Symptom:

P0714-TRANSMISSION TEMPERATURE SENSOR INTERMITTENT

When Monitored and Set Condition:

P0714-TRANSMISSION TEMPERATURE SENSOR INTERMITTENT

When Monitored: Continuously with the ignition on and engine running.

Set Condition: The DTC will set when the monitored Temperature Sensor voltage fluctuates or changes abruptly within a predetermined period of time.

POSSIBLE CAUSES

RELATED DTC'S PRESENT
 TRANSMISSION TEMPERATURE SENSOR
 TRANSMISSION CONTROL MODULE
 INTERMITTENT WIRING AND CONNECTORS

| TEST | ACTION | APPLICABILITY |
|------|---|---------------|
| 1 | <p>NOTE: Low fluid level can be the cause of many Transmission problems. If the fluid level is low, locate and repair the leak, then check and adjust the fluid level per the Service Information.</p> <p>NOTE: Always perform diagnostics with a fully charged battery to avoid false symptoms.</p> <p>With the DRBIII®, read the engine DTC's. Check and repair all engine DTC's prior to performing Transmission Symptom Diagnostics.</p> <p>With the DRBIII®, read Transmission DTC's. Record all DTC's and 1 Trip Failures.</p> <p>NOTE: Diagnose 1 Trip Failures as a fully matured DTC.</p> <p>Using the wiring diagram/schematic as a guide, inspect the wiring and connectors. Repair as necessary.</p> <p>Perform the Shift Lever Position Test. If the test does not pass, refer to Symptom test for P0706 Check Shifter Signal.</p> <p>For Gear Ratio DTC's, check and record all CVI's.</p> <p>Most DTC's set on start up but some must be set by driving the vehicle such that all diagnostic monitors have run.</p> <p>NOTE: Verify flash level of Transmission Control Module. Some problems are corrected by software upgrades to the Transmission Control Module.</p> <p>NOTE: Check for applicable TSB's related to the symptom.</p> <p>Perform this procedure prior to Symptom diagnosis.</p> <p>Continue Go To 2</p> | All |
| 2 | <p>With the DRBIII®, check Transmission DTC's.</p> <p>Are there any Speed Sensor and/or other Temperature Sensor DTCs present?</p> <p>Yes → Refer to the Transmission category and perform the appropriate symptom. Perform 42RLE TRANSMISSION VERIFICATION TEST - VER 1.</p> <p>No → Go To 3</p> | All |

P0714-TRANSMISSION TEMPERATURE SENSOR INTERMITTENT — Continued

| TEST | ACTION | APPLICABILITY |
|------|--|---------------|
| 3 | <p>With the DRBIII®, Check the STARTS SINCE SET counter for P0714. NOTE: This counter only applies to the last DTC set. Is the STARTS SINCE SET counter 2 or less?</p> <p>Yes → Go To 4 No → Go To 7</p> | All |
| 4 | <p>Turn the ignition off to the lock position. Remove the Starter Relay. NOTE: Failure to remove Starter Relay can cause a Transmission - No Response condition. Install the Transmission Simulator, Miller tool #8333 and the Electronic Transmission Adapter kit 8333-1. Note: Check connectors - Clean/repair as necessary. Ignition on, engine not running. With the Transmission Simulator, turn the Input/Output switch to OFF. With the DRBIII®, monitor the TRANS TEMP VOLTS while turning the Thermistor Voltage switch to all three positions on the Transmission Simulator. Compare the DRBIII® readings with the numbers listed on the Transmission Simulator. Do the readings on the Transmission Simulator match a non-fluctuating DRBIII® reading ± 0.2 volts?</p> <p>Yes → Go To 5 No → Go To 6</p> | All |
| 5 | <p>If there are no possible causes remaining, view repair.</p> <p>Repair Replace Transmission Solenoid/TRS Assembly per the Service Information. Perform 42RLE TRANSMISSION VERIFICATION TEST - VER 1.</p> | All |
| 6 | <p>Using the schematics as a guide, inspect the wiring and connectors. Repair as necessary. Pay particular attention to all power and ground circuits. If there are no possible causes remaining, view repair.</p> <p>Repair Replace the Transmission Control Module per the Service Information. WITH THE DRBIII® PERFORM QUICK LEARN. Perform 42RLE TRANSMISSION VERIFICATION TEST - VER 1.</p> | All |
| 7 | <p>The conditions necessary to set this DTC are not present at this time. Using the schematics as a guide, inspect the wiring and connectors specific to this circuit. Wiggle the wires while checking for shorts and open circuits. With the DRBIII®, check the EATX EVENT DATA to help identify the conditions in which the DTC was set. Were there any problems found?</p> <p>Yes → Repair as necessary. Perform 42RLE TRANSMISSION VERIFICATION TEST - VER 1. No → Test Complete.</p> | All |

Symptom:

P0715-INPUT SPEED SENSOR ERROR

When Monitored and Set Condition:

P0715-INPUT SPEED SENSOR ERROR

When Monitored: The transmission gear ratio is monitored continuously while the transmission is in gear.

Set Condition: If there is an excessive change in input RPM in any gear.

POSSIBLE CAUSES

- INPUT SPEED SENSOR SIGNAL CIRCUIT OPEN
- SPEED SENSOR GROUND CIRCUIT OPEN
- INPUT SPEED SENSOR SIGNAL CIRCUIT SHORT TO GROUND
- INPUT SPEED SENSOR SIGNAL CIRCUIT SHORT TO VOLTAGE
- SPEED SENSOR GROUND CIRCUIT SHORT TO VOLTAGE
- INPUT SPEED SENSOR ERROR
- TRANSMISSION CONTROL MODULE
- INTERMITTENT WIRING AND CONNECTORS

| TEST | ACTION | APPLICABILITY |
|------|--|---------------|
| 1 | <p>NOTE: Low fluid level can be the cause of many Transmission problems. If the fluid level is low, locate and repair the leak, then check and adjust the fluid level per the Service Information.</p> <p>NOTE: Always perform diagnostics with a fully charged battery to avoid false symptoms.</p> <p>With the DRBIII®, read the engine DTC's. Check and repair all engine DTC's prior to performing Transmission Symptom Diagnostics.</p> <p>With the DRBIII®, read Transmission DTC's. Record all DTC's and 1 Trip Failures.</p> <p>NOTE: Diagnose 1 Trip Failures as a fully matured DTC.</p> <p>Using the wiring diagram/schematic as a guide, inspect the wiring and connectors. Repair as necessary.</p> <p>Perform the Shift Lever Position Test. If the test does not pass, refer to Symptom test for P0706 Check Shifter Signal.</p> <p>For Gear Ratio DTC's, check and record all CVI's.</p> <p>Most DTC's set on start up but some must be set by driving the vehicle such that all diagnostic monitors have run.</p> <p>NOTE: Verify flash level of Transmission Control Module. Some problems are corrected by software upgrades to the Transmission Control Module.</p> <p>NOTE: Check for applicable TSB's related to the symptom.</p> <p>Perform this procedure prior to Symptom diagnosis.</p> <p style="text-align: center;">Continue Go To 2</p> | All |

P0715-INPUT SPEED SENSOR ERROR — Continued

| TEST | ACTION | APPLICABILITY |
|------|--|---------------|
| 2 | Start the engine in park. With the DRBIII®, read the Input RPM. Is the Input RPM reading below 400 RPM? Yes → Go To 3 No → Go To 11 | All |
| 3 | Turn the ignition off to the lock position. CAUTION: Remove the Starter Relay from the PDC. This will prevent the vehicle from being started in gear. Install the Transmission Simulator, Miller tool #8333 and the Electronic Transmission Adapter kit 8333-1. Ignition on, engine not running. With the Transmission Simulator, set the "Input/Output Speed" switch to "ON" and the rotary switch to the "3000/1250" position. With the DRBIII®, monitor the Input and Output RPM. Does the Input RPM read 3000 RPM and the Output RPM read 1250 RPM +/- 50 RPM? Yes → Go To 4 No → Go To 5 NOTE: Disconnect the Transmission Simulator and reconnect all harness connectors. | All |
| 4 | If there are no possible causes remaining, view repair. Repair Replace the Input Speed Sensor per the Service Information. Perform 42RLE TRANSMISSION VERIFICATION TEST - VER 1. | All |
| 5 | Turn the ignition off to the lock position. Disconnect the TCM harness connector. Disconnect the Input Speed Sensor harness connector. Note: Check connectors - Clean/repair as necessary. Measure the resistance of the Input Speed Sensor Signal circuit from the TCM harness connector to the Input Speed Sensor harness connector. Is the resistance above 5.0 ohms? Yes → Repair the Input Speed Sensor Signal circuit for an open. Perform 42RLE TRANSMISSION VERIFICATION TEST - VER 1. No → Go To 6 | All |
| 6 | Turn the ignition off to the lock position. Disconnect the TCM harness connector. Disconnect the Input Speed Sensor harness connector. Note: Check connectors - Clean/repair as necessary. Measure the resistance between ground and the Input Speed Sensor signal circuit. Is the resistance Below 5.0 ohms? Yes → Repair the Input Speed Sensor Signal circuit for a short to ground. Perform 42RLE TRANSMISSION VERIFICATION TEST - VER 1. No → Go To 7 | All |

P0715-INPUT SPEED SENSOR ERROR — Continued

| TEST | ACTION | APPLICABILITY |
|------|---|---------------|
| 7 | <p>Turn the ignition off to the lock position. Disconnect the Input Speed Sensor harness connector. Disconnect the TCM harness connector. Remove the Transmission Control Relay from the PDC. Note: Check connectors - Clean/repair as necessary. Connect a jumper wire between the Fused B+ circuit and the Transmission Control Relay Output circuit in the Transmission Control Relay connector. Ignition on, engine not running. Measure the voltage of the Input Speed Sensor Signal circuit in the TCM harness connector. Is the voltage above 0.5 volts?</p> <p>Yes → Repair the Input Speed Sensor Signal circuit for a short to voltage. Perform 42RLE TRANSMISSION VERIFICATION TEST - VER 1.</p> <p>No → Go To 8</p> | All |
| 8 | <p>Turn the ignition off to the lock position. Disconnect the TCM harness connector. Disconnect the Input Speed Sensor harness connector. Note: Check connectors - Clean/repair as necessary. Measure the resistance of the Speed Sensor Ground circuit from the TCM harness connector to the Input Speed Sensor harness connector. Is the resistance above 5.0 ohms?</p> <p>Yes → Repair the Speed Sensor Ground circuit for an open. Perform 42RLE TRANSMISSION VERIFICATION TEST - VER 1.</p> <p>No → Go To 9</p> | All |
| 9 | <p>Turn the ignition off to the lock position. Disconnect the TCM harness connector. Disconnect the TRS harness connector. Remove the Transmission Control Relay from the PDC. Note: Check connectors - Clean/repair as necessary. Connect a jumper wire between the Fused B+ circuit and the Transmission Control Relay Output circuit in the Transmission Control Relay connector in the PDC. Ignition on, engine not running. Measure the voltage of the Speed Sensor Ground circuit in the TCM harness connector. Is the voltage above 0.5 volts?</p> <p>Yes → Repair the Speed Sensor Ground circuit for a short to voltage. Perform 42RLE TRANSMISSION VERIFICATION TEST - VER 1.</p> <p>No → Go To 10</p> | All |
| 10 | <p>Using the schematics as a guide, inspect the wiring and connectors. Repair as necessary. Pay particular attention to all power and ground circuits. If there are no possible causes remaining, view repair.</p> <p>Repair</p> <p>Replace the Transmission Control Module per the Service Information. WITH THE DRBIII® PERFORM QUICK LEARN. Perform 42RLE TRANSMISSION VERIFICATION TEST - VER 1.</p> | All |

P0715-INPUT SPEED SENSOR ERROR — Continued

| TEST | ACTION | APPLICABILITY |
|-------------|---|----------------------|
| 11 | <p>The conditions necessary to set this DTC are not present at this time. Using the schematics as a guide, inspect the wiring and connectors specific to this circuit. Wiggle the wiring while checking for shorts and open circuits. With the DRBIII®, check the EATX EVENT DATA to help identify the conditions in which the DTC was set. Were there any problems found?</p> <p>Yes → Repair as necessary. Perform 42RLE TRANSMISSION VERIFICATION TEST - VER 1.</p> <p>No → Test Complete.</p> | All |

Symptom:

P0720-OUTPUT SPEED SENSOR ERROR

When Monitored and Set Condition:

P0720-OUTPUT SPEED SENSOR ERROR

When Monitored: The transmission gear ratio is monitored continuously while the transmission is in gear.

Set Condition: If there is an excessive change in output RPM in any gear.

POSSIBLE CAUSES

INTERMITTENT WIRING AND CONNECTORS
 OUTPUT SPEED SENSOR SIGNAL CIRCUIT OPEN
 SPEED SENSOR GROUND CIRCUIT OPEN
 OUTPUT SPEED SENSOR SIGNAL CIRCUIT SHORT TO GROUND
 OUTPUT SPEED SENSOR SIGNAL CIRCUIT SHORT TO VOLTAGE
 SPEED SENSOR GROUND CIRCUIT SHORT TO VOLTAGE
 OUTPUT SPEED SENSOR ERROR
 TRANSMISSION CONTROL MODULE

| TEST | ACTION | APPLICABILITY |
|----------|--|---------------|
| <p>1</p> | <p>NOTE: Low fluid level can be the cause of many Transmission problems. If the fluid level is low, locate and repair the leak, then check and adjust the fluid level per the Service Information. NOTE: Always perform diagnostics with a fully charged battery to avoid false symptoms. With the DRBIII®, read the engine DTC's. Check and repair all engine DTC's prior to performing Transmission Symptom Diagnostics. With the DRBIII®, read Transmission DTC's. Record all DTC's and 1 Trip Failures. NOTE: Diagnose 1 Trip Failures as a fully matured DTC. Using the wiring diagram/schematic as a guide, inspect the wiring and connectors. Repair as necessary. Perform the Shift Lever Position Test. If the test does not pass, refer to Symptom test for P0706 Check Shifter Signal. For Gear Ratio DTC's, check and record all CVI's. Most DTC's set on start up but some must be set by driving the vehicle such that all diagnostic monitors have run. NOTE: Verify flash level of Transmission Control Module. Some problems are corrected by software upgrades to the Transmission Control Module. NOTE: Check for applicable TSB's related to the symptom. Perform this procedure prior to Symptom diagnosis.</p> <p style="text-align: center;">Continue Go To 2</p> | <p>All</p> |

P0720-OUTPUT SPEED SENSOR ERROR — Continued

| TEST | ACTION | APPLICABILITY |
|------|---|---------------|
| 2 | Start the engine in park. Raise the drive wheels off of the ground. WARNING: PROPERLY SUPPORT THE VEHICLE. Place transmission in drive, release foot from brake. WARNING: BE SURE TO KEEP HANDS AND FEET CLEAR OF ROTATING WHEELS. Note: The drive wheels must be turning at this point. With the DRBIII®, read the Output RPM Is the Output RPM below 100 RPM? Yes → Go To 3 No → Go To 11 | All |
| 3 | Turn the ignition off to the lock position. CAUTION: Remove the Starter Relay from the PDC. This will prevent the vehicle from being started in gear. Install the Transmission Simulator, Miller tool #8333 and the Electronic Transmission Adapter kit 8333-1. Ignition on, engine not running. With the Transmission Simulator, set the "Input/Output Speed" switch to "ON" and the rotary switch to the "3000/1250" position. With the DRBIII®, read the Input RPM and Output RPM. Does the Input RPM read 3000 and the Output RPM read 1250 ± 50 RPM? Yes → Go To 4 No → Go To 5 | All |
| 4 | If there are no possible causes remaining, view repair. Repair Replace the Output Speed Sensor per the Service Information. Perform 42RLE TRANSMISSION VERIFICATION TEST - VER 1. | All |
| 5 | Turn the ignition off to the lock position. Disconnect the TCM harness connector. Disconnect the Output Speed Sensor harness connector. Note: Check connectors - Clean/repair as necessary. Measure the resistance of the Output Speed Sensor Signal circuit from the TCM harness connector to the Output Speed Sensor harness connector. Is the resistance above 5.0 ohms? Yes → Repair the Output Speed Sensor Signal circuit for an open. Perform 42RLE TRANSMISSION VERIFICATION TEST - VER 1. No → Go To 6 | All |

P0720-OUTPUT SPEED SENSOR ERROR — Continued

| TEST | ACTION | APPLICABILITY |
|------|---|---------------|
| 6 | <p>Turn the ignition off to the lock position. Disconnect the TCM harness connector. Disconnect the Output Speed Sensor harness connector. Note: Check connectors - Clean/repair as necessary. Measure the resistance between ground and the Output Speed Sensor Signal circuit. Is the resistance Below 5.0 ohms?</p> <p style="padding-left: 40px;">Yes → Repair the Output Speed Sensor Signal circuit for a short to ground. Perform 42RLE TRANSMISSION VERIFICATION TEST - VER 1.</p> <p style="padding-left: 40px;">No → Go To 7</p> | All |
| 7 | <p>Turn ignition off to the lock position. Disconnect the TCM harness connector. Disconnect the Transmission Simulator. Remove the Transmission Control Relay from the PDC. Note: Check connectors - Clean/repair as necessary. Connect a jumper wire between the Fused B(+) and Transmission Control Relay Output circuits in the Transmission Control Relay connector (In PDC). Ignition on, engine not running. Measure the voltage of the Output Speed Sensor Signal circuit in the TCM connector. Is the voltage above 3.0 volts?</p> <p style="padding-left: 40px;">Yes → Repair Output Speed Sensor Signal circuit short to voltage. Perform 42RLE TRANSMISSION VERIFICATION TEST - VER 1.</p> <p style="padding-left: 40px;">No → Go To 8</p> | All |
| 8 | <p>Turn the ignition off to the lock position. Disconnect the TCM harness connector. Disconnect the Output Speed Sensor harness connector. Note: Check connectors - Clean/repair as necessary. Measure the resistance of the Speed Sensor Ground circuit from the TCM harness connector to the Output Speed Sensor harness connector. Is the resistance above 5.0 ohms?</p> <p style="padding-left: 40px;">Yes → Repair the Speed Sensor Ground circuit for an open. Perform 42RLE TRANSMISSION VERIFICATION TEST - VER 1.</p> <p style="padding-left: 40px;">No → Go To 9</p> | All |
| 9 | <p>Turn ignition off to the lock position. Disconnect the TCM harness connector. Disconnect the TRS harness connector. Remove the Transmission Control Relay from the PDC. Note: Check connectors - Clean/repair as necessary. Connect a jumper wire between the Fused B(+) and Transmission Control Relay Output circuits in the Transmission Control Relay connector (In PDC). Ignition on, engine not running. Measure the voltage of the Speed Sensor Ground circuit in the TCM connector. Is the voltage above 3.0 volts?</p> <p style="padding-left: 40px;">Yes → Repair the Speed Sensor Ground circuit for a short to voltage. Perform 42RLE TRANSMISSION VERIFICATION TEST - VER 1.</p> <p style="padding-left: 40px;">No → Go To 10</p> | All |

P0720-OUTPUT SPEED SENSOR ERROR — Continued

| TEST | ACTION | APPLICABILITY |
|------|---|---------------|
| 10 | <p>Using the schematics as a guide, inspect the wiring and connectors. Repair as necessary. Pay particular attention to all power and ground circuits. If there are no possible causes remaining, view repair.</p> <p style="padding-left: 40px;">Repair</p> <p style="padding-left: 80px;">Replace the Transmission Control Module per the Service Information. WITH THE DRBIII® PERFORM QUICK LEARN. Perform 42RLE TRANSMISSION VERIFICATION TEST - VER 1.</p> | All |
| 11 | <p>The conditions necessary to set this DTC are not present at this time. Using the schematics as a guide, inspect the wiring and connectors specific to this circuit. Wiggle the wiring while checking for shorts and open circuits. With the DRBIII®, check the EATX EVENT DATA to help identify the conditions in which the DTC was set. Were there any problems found?</p> <p style="padding-left: 40px;">Yes → Repair as necessary. Perform 42RLE TRANSMISSION VERIFICATION TEST - VER 1.</p> <p style="padding-left: 40px;">No → Test Complete.</p> | All |

Symptom:

P0725-ENGINE SPEED SENSOR CIRCUIT

When Monitored and Set Condition:

P0725-ENGINE SPEED SENSOR CIRCUIT

When Monitored: Whenever the engine is running.

Set Condition: Engine RPM less than 390 or greater than 8000 for more than 2 seconds while the engine is running.

POSSIBLE CAUSES

INTERMITTENT WIRING & CONNECTORS CONDITIONS
 EATX RPM SIGNAL CIRCUIT OPEN
 EATX RPM SIGNAL CIRCUIT SHORTED TO GROUND
 EATX RPM SIGNAL CIRCUIT SHORTED TO VOLTAGE
 TRANSMISSION CONTROL MODULE
 POWERTRAIN CONTROL MODULE

| TEST | ACTION | APPLICABILITY |
|------|--|---------------|
| 1 | <p>NOTE: Low fluid level can be the cause of many Transmission problems. If the fluid level is low, locate and repair the leak, then check and adjust the fluid level per the Service Information.</p> <p>NOTE: Always perform diagnostics with a fully charged battery to avoid false symptoms.</p> <p>With the DRBIII®, read the engine DTC's. Check and repair all engine DTC's prior to performing Transmission Symptom Diagnostics.</p> <p>With the DRBIII®, read Transmission DTC's. Record all DTC's and 1 Trip Failures.</p> <p>NOTE: Diagnose 1 Trip Failures as a fully matured DTC.</p> <p>Using the wiring diagram/schematic as a guide, inspect the wiring and connectors. Repair as necessary.</p> <p>Perform the Shift Lever Position Test. If the test does not pass, refer to Symptom test for P0706 Check Shifter Signal.</p> <p>For Gear Ratio DTC's, check and record all CVT's.</p> <p>Most DTC's set on start up but some must be set by driving the vehicle such that all diagnostic monitors have run.</p> <p>NOTE: Verify flash level of Transmission Control Module. Some problems are corrected by software upgrades to the Transmission Control Module.</p> <p>NOTE: Check for applicable TSB's related to the symptom.</p> <p>Perform this procedure prior to Symptom diagnosis.</p> <p>Continue Go To 2</p> | All |

P0725-ENGINE SPEED SENSOR CIRCUIT — Continued

| TEST | ACTION | APPLICABILITY |
|------|--|---------------|
| 2 | <p>NOTE: This code is not a Transmission Input Speed Sensor DTC With the DRBIII®, Check the STARTS SINCE SET counter. NOTE: This counter only applies to the last DTC set. Is the STARTS SINCE SET counter set at 0?</p> <p>Yes → Go To 3 No → Go To 8</p> | All |
| 3 | <p>Turn ignition off to the lock position. Disconnect the Powertrain Control Module (PCM) harness connector. Disconnect the TCM harness connector. Note: Check connectors - Clean/repair as necessary. Measure the resistance of the EATX RPM signal circuit between the TCM connector and the PCM connector. Is the resistance above 5.0 ohms?</p> <p>Yes → Repair the open EATX RPM Signal circuit. Perform 42RLE TRANSMISSION VERIFICATION TEST - VER 1. No → Go To 4</p> | All |
| 4 | <p>Turn ignition off to the lock position. Disconnect the Powertrain Control Module (PCM) harness connector. Disconnect the TCM harness connector. Note: Check connectors - Clean/repair as necessary. Measure the resistance between the EATX RPM Signal circuit and ground. Is the resistance below 5.0 ohms?</p> <p>Yes → Repair the EATX RPM Signal circuit for a short to ground. Perform 42RLE TRANSMISSION VERIFICATION TEST - VER 1. No → Go To 5</p> | All |
| 5 | <p>Turn ignition off to the lock position. Disconnect the PCM harness connector. Note: Check connectors - Clean/repair as necessary. Ignition on, engine not running. Measure the voltage of the EATX RPM Signal circuit in the PCM connector. Is the voltage above 10.0 volts?</p> <p>Yes → Repair the EATX RPM Signal circuit for a short to voltage. Perform 42RLE TRANSMISSION VERIFICATION TEST - VER 1. No → Go To 6</p> | All |
| 6 | <p>Turn the ignition off to the lock position. Disconnect the PCM harness connector. Note: Check connectors - Clean/repair as necessary. Ignition on, engine not running. Measure the voltage of the EATX RPM Signal circuit. Is the voltage between 4.5 and 5.5 volts?</p> <p>Yes → Replace and program the Powertrain Control Module per the Service Information. Perform 42RLE TRANSMISSION VERIFICATION TEST - VER 1. No → Go To 7</p> | All |

P0725-ENGINE SPEED SENSOR CIRCUIT — Continued

| TEST | ACTION | APPLICABILITY |
|------|--|---------------|
| 7 | <p>Using the schematics as a guide, inspect the wiring and connectors. Repair as necessary. Pay particular attention to all power and ground circuits. If there are no possible causes remaining, view repair.</p> <p style="padding-left: 40px;">Repair</p> <p style="padding-left: 80px;">Replace the Transmission Control Module per the Service Information. WITH THE DRBIII® PERFORM QUICK LEARN. Perform 42RLE TRANSMISSION VERIFICATION TEST - VER 1.</p> | All |
| 8 | <p>The conditions necessary to set the DTC are not present at this time. Using the schematics as a guide, inspect the wiring and connectors specific to this circuit. Wiggle the wires while checking for shorts and open circuits. Check the power and ground circuits of the Transmission Control Module. Check the vehicles battery condition. Were any problems found?</p> <p style="padding-left: 40px;">Yes → Repair wiring and/or connectors as necessary. Perform 42RLE TRANSMISSION VERIFICATION TEST - VER 1.</p> <p style="padding-left: 40px;">No → Test Complete.</p> | All |

Symptom:**P0731-GEAR RATIO ERROR IN 1ST****When Monitored and Set Condition:****P0731-GEAR RATIO ERROR IN 1ST**

When Monitored: The Transmission Gear Ratio is monitored continuously while the Transmission is in gear.

Set Condition: If the ratio of the input RPM to the output RPM does not match the current Gear Ratio.

POSSIBLE CAUSES

RELATED DTC'S PRESENT
INTERMITTENT GEAR RATIO ERRORS
INTERNAL TRANSMISSION

| TEST | ACTION | APPLICABILITY |
|-------------|--|----------------------|
| 1 | <p>NOTE: Low fluid level can be the cause of many Transmission problems. If the fluid level is low, locate and repair the leak, then check and adjust the fluid level per the Service Information.</p> <p>NOTE: Always perform diagnostics with a fully charged battery to avoid false symptoms.</p> <p>With the DRBIII®, read the engine DTC's. Check and repair all engine DTC's prior to performing Transmission Symptom Diagnostics.</p> <p>With the DRBIII®, read Transmission DTC's. Record all DTC's and 1 Trip Failures.</p> <p>NOTE: Diagnose 1 Trip Failures as a fully matured DTC.</p> <p>Using the wiring diagram/schematic as a guide, inspect the wiring and connectors. Repair as necessary.</p> <p>Perform the Shift Lever Position Test. If the test does not pass, refer to Symptom test for P0706 Check Shifter Signal.</p> <p>For Gear Ratio DTC's, check and record all CVI's.</p> <p>Most DTC's set on start up but some must be set by driving the vehicle such that all diagnostic monitors have run.</p> <p>NOTE: Verify flash level of Transmission Control Module. Some problems are corrected by software upgrades to the Transmission Control Module.</p> <p>NOTE: Check for applicable TSB's related to the symptom.</p> <p>Perform this procedure prior to Symptom diagnosis.</p> <p>Continue Go To 2</p> | All |
| 2 | <p>With the DRBIII®, read Transmission DTC's</p> <p>If any of these DTC's are present, perform their respective tests first.</p> <p>Are the DTC's P0944, P0715, P0720, or P1794 present also?</p> <p>Yes → Refer to the Transmission category and perform the appropriate symptom. If any of these DTC's are present, they will cause a gear ratio error. Perform the test for Loss of Prime first if it is present. Perform 42RLE TRANSMISSION VERIFICATION TEST - VER 1.</p> <p>No → Go To 3</p> | All |

P0731-GEAR RATIO ERROR IN 1ST — Continued

| TEST | ACTION | APPLICABILITY |
|------|---|---------------|
| 3 | <p>With the DRBIII®, perform the 1st Gear Clutch Test. Follow the instructions on the DRBIII®.</p> <p>Increase the throttle angle, TPS Degree, to 30° for no more than a few seconds.</p> <p>CAUTION: Do not overheat the transmission.</p> <p>Did the Clutch Test pass, Input Speed remain at 0?</p> <p style="padding-left: 40px;">Yes → Go To 4</p> <p style="padding-left: 40px;">No → Go To 5</p> | All |
| 4 | <p>The conditions to set this DTC are not present at this time.</p> <p>Check the gearshift linkage adjustment.</p> <p>Gear ratio DTC's can be set by problems in the Input and Output Speed Sensor circuits. If the vehicle passes the clutch test and still sets gear ratio DTC(s), check the Speed Sensors for proper operation.</p> <p>NOTE: Remove the Starter Relay from the PDC. This will prevent the vehicle from being started in gear.</p> <p>Check the Speed Sensor wiring and connectors for good connection, then perform a wiggle test using the Transmission Simulator, Miller tool #8333 and the Electronic Transmission Adapter kit 8333-1A.</p> <p>This DTC can also be set under extreme temperature conditions, this is usually caused by an internal problem. Verify if the problem is only experienced under extreme hot or cold conditions.</p> <p>With the DRBIII®, check the EATX EVENT DATA to help identify the conditions in which the DTC was set.</p> <p>Were there any problems found?</p> <p style="padding-left: 40px;">Yes → Repair as necessary. Perform 42RLE TRANSMISSION VERIFICATION TEST - VER 1.</p> <p style="padding-left: 40px;">No → Test Complete.</p> | All |
| 5 | <p>If there are no possible causes remaining, view repair.</p> <p style="padding-left: 40px;">Repair</p> <p style="padding-left: 80px;">Repair internal transmission per the Service Information. Check all components related to the Underdrive and L/R clutches. Inspect the Oil Pump per the Service Information and repair or replace as necessary.</p> <p style="padding-left: 80px;">Perform 42RLE TRANSMISSION VERIFICATION TEST - VER 1.</p> | All |

Symptom:**P0732-GEAR RATIO ERROR IN 2ND****When Monitored and Set Condition:****P0732-GEAR RATIO ERROR IN 2ND**

When Monitored: The Transmission Gear Ratio is monitored continuously while the Transmission is in Gear.

Set Condition: If the ratio of the input RPM to the output RPM does not match the current Gear Ratio.

POSSIBLE CAUSES

RELATED DTC'S PRESENT

RELATED PRESSURE SWITCH DTC'S PRESENT

INTERMITTENT GEAR RATIO ERRORS

TRANSMISSION - INTERNAL

| TEST | ACTION | APPLICABILITY |
|------|--|---------------|
| 1 | <p>NOTE: Low fluid level can be the cause of many Transmission problems. If the fluid level is low, locate and repair the leak, then check and adjust the fluid level per the Service Information.</p> <p>NOTE: Always perform diagnostics with a fully charged battery to avoid false symptoms.</p> <p>With the DRBIII®, read the engine DTC's. Check and repair all engine DTC's prior to performing Transmission Symptom Diagnostics.</p> <p>With the DRBIII®, read Transmission DTC's. Record all DTC's and 1 Trip Failures.</p> <p>NOTE: Diagnose 1 Trip Failures as a fully matured DTC.</p> <p>Using the wiring diagram/schematic as a guide, inspect the wiring and connectors. Repair as necessary.</p> <p>Perform the Shift Lever Position Test. If the test does not pass, refer to Symptom test for P0706 Check Shifter Signal.</p> <p>For Gear Ratio DTC's, check and record all CVI's.</p> <p>Most DTC's set on start up but some must be set by driving the vehicle such that all diagnostic monitors have run.</p> <p>NOTE: Verify flash level of Transmission Control Module. Some problems are corrected by software upgrades to the Transmission Control Module.</p> <p>NOTE: Check for applicable TSB's related to the symptom.</p> <p>Perform this procedure prior to Symptom diagnosis.</p> <p>Continue Go To 2</p> | All |

P0732-GEAR RATIO ERROR IN 2ND — Continued

| TEST | ACTION | APPLICABILITY |
|------|--|---------------|
| 2 | <p>With the DRBIII®, read Transmission DTC's If any of these DTC's are present, perform their respective tests first. Are the DTC's P0944, P0715, P0720, or P1794 present also?</p> <p>Yes → Refer to the Transmission category and perform the appropriate symptom. If any of these DTC's are present, they will cause a gear ratio error. Perform the test for Loss of Prime first if it is present. Perform 42RLE TRANSMISSION VERIFICATION TEST - VER 1.</p> <p>No → Go To 3</p> | All |
| 3 | <p>With the DRBIII®, perform the 2nd Gear Clutch Test. Follow the instructions on the DRBIII®. Increase the Throttle Angle, TPS Degree, to 30° for no more than a few seconds. CAUTION: Do not overheat the transmission. Did the Clutch Test pass, Input Speed remain at 0?</p> <p>Yes → Go To 4</p> <p>No → Go To 5</p> | All |
| 4 | <p>The conditions to set this DTC are not present at this time. Check the gearshift linkage adjustment. Gear ratio DTC's can be set by problems in the Input and Output Speed Sensor circuits. If the vehicle passes the clutch test and still sets Gear Ratio DTC(s), check the Speed Sensors for proper operation. NOTE: Remove the Starter Relay from the PDC. This will prevent the vehicle from being started in gear. Check the Speed Sensor wiring and connectors for good connection, then perform a wiggle test using the Transmission Simulator, Miller tool #8333 and the Electronic Transmission Adapter kit 8333-1A. This DTC can also be set under extreme temperature conditions, this is usually caused by an internal problem. Verify if the problem is only experienced under extreme hot or cold conditions. With the DRBIII®, check the EATX EVENT DATA to help identify the conditions in which the DTC was set. Were there any problems found?</p> <p>Yes → Repair as necessary. Perform 42RLE TRANSMISSION VERIFICATION TEST - VER 1.</p> <p>No → Test Complete.</p> | All |
| 5 | <p>With the DRBIII®, read Transmission DTC's. Is the DTC P0845 and/or P0846 present also?</p> <p>Yes → Replace the Solenoid/Pressure Switch Assembly per the Service Information. Perform 42RLE TRANSMISSION VERIFICATION TEST - VER 1.</p> <p>No → Go To 6</p> | All |

P0732-GEAR RATIO ERROR IN 2ND — Continued

| TEST | ACTION | APPLICABILITY |
|-------------|--|----------------------|
| 6 | If there are no possible causes remaining, view repair. Repair Repair internal transmission problem. Check all of the components related to the Underdrive and 2/4 clutches. Inspect the Oil Pump per the Service Information and repair or replace as necessary. Perform 42RLE TRANSMISSION VERIFICATION TEST - VER 1. | All |

Symptom:

P0733-GEAR RATIO ERROR IN 3RD

When Monitored and Set Condition:

P0733-GEAR RATIO ERROR IN 3RD

When Monitored: The Transmission Gear Ratio is monitored continuously while the Transmission is in Gear.

Set Condition: If the ratio of the input RPM to the output RPM does not match the current Gear Ratio.

POSSIBLE CAUSES

RELATED DTC'S PRESENT

TRANSMISSION SOLENOID PRESSURE SWITCH ASSEMBLY

INTERNAL TRANSMISSION

INTERMITTENT GEAR RATIO ERRORS

| TEST | ACTION | APPLICABILITY |
|------|--|---------------|
| 1 | <p>NOTE: Low fluid level can be the cause of many Transmission problems. If the fluid level is low, locate and repair the leak, then check and adjust the fluid level per the Service Information.</p> <p>NOTE: Always perform diagnostics with a fully charged battery to avoid false symptoms.</p> <p>With the DRBIII®, read the engine DTC's. Check and repair all engine DTC's prior to performing Transmission Symptom Diagnostics.</p> <p>With the DRBIII®, read Transmission DTC's. Record all DTC's and 1 Trip Failures.</p> <p>NOTE: Diagnose 1 Trip Failures as a fully matured DTC.</p> <p>Using the wiring diagram/schematic as a guide, inspect the wiring and connectors. Repair as necessary.</p> <p>Perform the Shift Lever Position Test. If the test does not pass, refer to Symptom test for P0706 Check Shifter Signal.</p> <p>For Gear Ratio DTC's, check and record all CVI's.</p> <p>Most DTC's set on start up but some must be set by driving the vehicle such that all diagnostic monitors have run.</p> <p>NOTE: Verify flash level of Transmission Control Module. Some problems are corrected by software upgrades to the Transmission Control Module.</p> <p>NOTE: Check for applicable TSB's related to the symptom.</p> <p>Perform this procedure prior to Symptom diagnosis.</p> <p style="text-align: center;">Continue Go To 2</p> | All |

P0733-GEAR RATIO ERROR IN 3RD — Continued

| TEST | ACTION | APPLICABILITY |
|------|--|---------------|
| 2 | <p>With the DRBIII®, read Transmission DTC's If any of these DTC's are present, perform their respective tests first. Are the DTC's P0944, P0715, P0720, or P1794 present also?</p> <p>Yes → Refer to the Transmission category and perform the appropriate symptom. If any of these DTC's are present, they will cause a gear ratio error. Perform the test for Loss of Prime first if it is present. Perform 42RLE TRANSMISSION VERIFICATION TEST - VER 1.</p> <p>No → Go To 3</p> | All |
| 3 | <p>With the DRBIII®, perform the 3rd gear clutch test. Follow the instructions on the DRBIII®. Increase the throttle angle, TPS Degree, to 30° for no more than a few seconds. CAUTION: Do not overheat the transmission. Did the Clutch Test pass, Input Speed remain at 0?</p> <p>Yes → Go To 4</p> <p>No → Go To 5</p> | All |
| 4 | <p>The conditions to set this DTC are not present at this time. Check the gearshift linkage adjustment. Gear ratio DTC's can be set by problems in the Input and Output Speed Sensor circuits. If the vehicle passes the clutch test and still sets Rear Ratio DTC(s), check the Speed Sensors for proper operation. NOTE: Remove the Starter Relay from the PDC. This will prevent the vehicle from being started in gear. Check the speed sensor wiring and connectors for good connection, then perform a wiggle test using the Transmission Simulator, Miller tool #8333 and the Electronic Transmission Adapter kit 8333-1A. This DTC can also be set under extreme temperature conditions, this is usually caused by an internal problem. Verify if the problem is only experienced under extreme hot or cold conditions. With the DRBIII®, check the EATX EVENT DATA to help identify the conditions in which the DTC was set. Were there any problems found?</p> <p>Yes → Repair as necessary. Perform 42RLE TRANSMISSION VERIFICATION TEST - VER 1.</p> <p>No → Test Complete.</p> | All |
| 5 | <p>With the DRBIII®, read Transmission DTC's. Is the DTC P0870 and/or P0871 present also?</p> <p>Yes → Replace the Transmission Solenoid/Pressure Switch Assembly per the Service Information. Perform 42RLE TRANSMISSION VERIFICATION TEST - VER 1.</p> <p>No → Go To 6</p> | All |

P0733-GEAR RATIO ERROR IN 3RD — Continued

| TEST | ACTION | APPLICABILITY |
|------|---|---------------|
| 6 | <p>If there are no possible causes remaining, view repair.</p> <p>Repair</p> <p>Repair internal transmission per the Service Information. Check all of the components related to the Underdrive and Overdrive clutches. Inspect the Oil Pump per the Service Information and repair or replace as necessary.</p> <p>Perform 42RLE TRANSMISSION VERIFICATION TEST - VER 1.</p> | All |

Symptom:
P0734-GEAR RATIO ERROR IN 4TH

When Monitored and Set Condition:

P0734-GEAR RATIO ERROR IN 4TH

When Monitored: The Transmission Gear Ratio is monitored continuously while the Transmission is in Gear.

Set Condition: If the ratio of the input RPM to the output RPM does not match the current Gear Ratio.

POSSIBLE CAUSES

RELATED DTC'S PRESENT
 RELATED PRESSURE SWITCH DTC'S PRESENT
 INTERMITTENT GEAR RATIO ERRORS
 TRANSMISSION - INTERNAL

| TEST | ACTION | APPLICABILITY |
|------|---|---------------|
| 1 | <p>NOTE: Low fluid level can be the cause of many Transmission problems. If the fluid level is low, locate and repair the leak, then check and adjust the fluid level per the Service Information.</p> <p>NOTE: Always perform diagnostics with a fully charged battery to avoid false symptoms.</p> <p>With the DRBIII®, read the engine DTC's. Check and repair all engine DTC's prior to performing Transmission Symptom Diagnostics.</p> <p>With the DRBIII®, read Transmission DTC's. Record all DTC's and 1 Trip Failures.</p> <p>NOTE: Diagnose 1 Trip Failures as a fully matured DTC.</p> <p>Using the wiring diagram/schematic as a guide, inspect the wiring and connectors. Repair as necessary.</p> <p>Perform the Shift Lever Position Test. If the test does not pass, refer to Symptom test for P0706 Check Shifter Signal.</p> <p>For Gear Ratio DTC's, check and record all CVI's.</p> <p>Most DTC's set on start up but some must be set by driving the vehicle such that all diagnostic monitors have run.</p> <p>NOTE: Verify flash level of Transmission Control Module. Some problems are corrected by software upgrades to the Transmission Control Module.</p> <p>NOTE: Check for applicable TSB's related to the symptom.</p> <p>Perform this procedure prior to Symptom diagnosis.</p> <p>Continue Go To 2</p> | All |

P0734-GEAR RATIO ERROR IN 4TH — Continued

| TEST | ACTION | APPLICABILITY |
|------|--|---------------|
| 2 | <p>With the DRBIII®, read Transmission Control Module DTC's If any of these DTC's are present, perform their respective tests first. Are the DTC's P0944, P0715, P0720, or P1794 present also?</p> <p>Yes → Refer to the Transmission category and perform the appropriate symptom. If any of these DTC's are present, they will cause a gear ratio error. Perform the test for Loss of Prime first if it is present. Perform 42RLE TRANSMISSION VERIFICATION TEST - VER 1.</p> <p>No → Go To 3</p> | All |
| 3 | <p>With the DRBIII®, perform the 4th gear clutch test. Follow the instructions on the DRBIII®. Increase the throttle angle, TPS Degree, to 30° for no more than a few seconds. CAUTION: Do not overheat the transmission. Did the Clutch Test pass, Input Speed remain at 0?</p> <p>Yes → Go To 4</p> <p>No → Go To 5</p> | All |
| 4 | <p>The conditions to set this DTC are not present at this time. Check the gearshift linkage adjustment. Gear Ratio DTC's can be set by problems in the Input and Output Speed Sensor circuits. If the vehicle passes the clutch test and still sets Gear Ratio DTC(s), check the Speed Sensors for proper operation. NOTE: Remove the Starter Relay from the PDC. This will prevent the vehicle from being started in gear. Check the Speed Sensor wiring and connectors for good connection, then perform a wiggle test using the Transmission Simulator, Miller tool #8333 and the Electronic Transmission Adapter kit 8333-1A. This DTC can also be set under extreme temperature conditions, this is usually caused by an internal problem. Verify if the problem is only experienced under extreme hot or cold conditions. With the DRBIII®, check the EATX EVENT DATA to help identify the conditions in which the DTC was set. Were there any problems found?</p> <p>Yes → Repair as necessary. Perform 42RLE TRANSMISSION VERIFICATION TEST - VER 1.</p> <p>No → Test Complete.</p> | All |
| 5 | <p>With the DRBIII®, read Transmission DTC's. Is the DTC P0845 and/or P0846 present also?</p> <p>Yes → Replace the Solenoid/Pressure Switch Assembly per the Service Information. Perform 42RLE TRANSMISSION VERIFICATION TEST - VER 1.</p> <p>No → Go To 6</p> | All |

P0734-GEAR RATIO ERROR IN 4TH — Continued

| TEST | ACTION | APPLICABILITY |
|------|---|---------------|
| 6 | If there are no possible causes remaining, view repair. Repair Repair internal transmission problem. Check all of the components related to the Overdrive and 2/4 clutches. Inspect the Oil Pump per the Service Information and repair or replace as necessary. Perform 42RLE TRANSMISSION VERIFICATION TEST - VER 1. | All |

Symptom:

P0736-GEAR RATIO ERROR IN REVERSE

When Monitored and Set Condition:

P0736-GEAR RATIO ERROR IN REVERSE

When Monitored: The Transmission Gear Ratio is monitored continuously while the Transmission is in Gear.

Set Condition: If the ratio of the input RPM to the output RPM does not match the current Gear Ratio.

POSSIBLE CAUSES

RELATED DTC'S PRESENT
 INTERMITTENT GEAR RATIO ERRORS
 TRANSMISSION - INTERNAL

| TEST | ACTION | APPLICABILITY |
|------|--|---------------|
| 1 | <p>NOTE: Low fluid level can be the cause of many Transmission problems. If the fluid level is low, locate and repair the leak, then check and adjust the fluid level per the Service Information.</p> <p>NOTE: Always perform diagnostics with a fully charged battery to avoid false symptoms.</p> <p>With the DRBIII®, read the engine DTC's. Check and repair all engine DTC's prior to performing Transmission Symptom Diagnostics.</p> <p>With the DRBIII®, read Transmission DTC's. Record all DTC's and 1 Trip Failures.</p> <p>NOTE: Diagnose 1 Trip Failures as a fully matured DTC.</p> <p>Using the wiring diagram/schematic as a guide, inspect the wiring and connectors. Repair as necessary.</p> <p>Perform the Shift Lever Position Test. If the test does not pass, refer to Symptom test for P0706 Check Shifter Signal.</p> <p>For Gear Ratio DTC's, check and record all CVI's.</p> <p>Most DTC's set on start up but some must be set by driving the vehicle such that all diagnostic monitors have run.</p> <p>NOTE: Verify flash level of Transmission Control Module. Some problems are corrected by software upgrades to the Transmission Control Module.</p> <p>NOTE: Check for applicable TSB's related to the symptom.</p> <p>Perform this procedure prior to Symptom diagnosis.</p> <p style="text-align: center;">Continue Go To 2</p> | All |
| 2 | <p>With the DRBIII®, read Transmission DTC's</p> <p>If any of these DTC's are present, perform their respective tests first.</p> <p>Are the DTC's P0944, P0715, P0720, P1794, or present also?</p> <p style="padding-left: 40px;">Yes → Refer to the Transmission category and perform the appropriate symptom. If any of these DTC's are present, they will cause a gear ratio error. Perform the test for Loss of Prime first if it is present. Perform 42RLE TRANSMISSION VERIFICATION TEST - VER 1.</p> <p style="padding-left: 40px;">No → Go To 3</p> | All |

P0736-GEAR RATIO ERROR IN REVERSE — Continued

| TEST | ACTION | APPLICABILITY |
|------|---|---------------|
| 3 | <p>With the DRBIII®, perform the Reverse gear clutch test. Follow the instructions on the DRBIII®.</p> <p>Increase the throttle angle, TPS Degree, to 30° for no more than a few seconds.</p> <p>CAUTION: Do not overheat the Transmission.</p> <p>Did the Clutch Test pass, Input Speed remain at 0?</p> <p style="padding-left: 40px;">Yes → Go To 4</p> <p style="padding-left: 40px;">No → Go To 5</p> | All |
| 4 | <p>The conditions to set this DTC are not present at this time.</p> <p>Check the gearshift linkage adjustment.</p> <p>Gear Ratio DTC's can be set by problems in the Input and Output Speed Sensor circuits. If the vehicle passes the clutch test and still sets Gear Ratio DTC(s), check the Speed Sensors for proper operation.</p> <p>NOTE: Remove the Starter Relay from the PDC. This will prevent the vehicle from being started in gear.</p> <p>Check the speed sensor wiring and connectors for good connection, then perform a wiggle test using the Transmission Simulator, Miller tool #8333 and the Electronic Transmission Adapter kit 8333-1A.</p> <p>This DTC can also be set under extreme temperature conditions, this is usually caused by an internal problem. Verify if the problem is only experienced under extreme hot or cold conditions.</p> <p>With the DRBIII®, check the EATX EVENT DATA to help identify the conditions in which the DTC was set.</p> <p>Were there any problems found?</p> <p style="padding-left: 40px;">Yes → Repair as necessary. Perform 42RLE TRANSMISSION VERIFICATION TEST - VER 1.</p> <p style="padding-left: 40px;">No → Test Complete.</p> | All |
| 5 | <p>If there are no possible causes remaining, view repair.</p> <p style="padding-left: 40px;">Repair</p> <p style="padding-left: 80px;">Repair internal transmission problem. Check all of the components related to the Reverse and L/R clutches. Inspect the Oil Pump per the Service Information and repair or replace as necessary.</p> <p style="padding-left: 80px;">Perform 42RLE TRANSMISSION VERIFICATION TEST - VER 1.</p> | All |

Symptom:

P0740-TORQUE CONVERTER CLUTCH CONTROL CIRCUIT

When Monitored and Set Condition:

P0740-TORQUE CONVERTER CLUTCH CONTROL CIRCUIT

When Monitored: During Electronically Modulated Converter Clutch (EMCC) Operation.

Set Condition: A) Transmission must be in EMCC, with input speed > than 1750 RPM. TCC/L-R sol achieves the maximum duty cycle & can't pull engine RPM within 60 RPM of input speed. B) Transmissions is in FEMCC & engine slips TCC > than 100 RPM for 10 seconds.

POSSIBLE CAUSES

RELATED DTC'S PRESENT
INTERNAL TRANSMISSION
INTERMITTENT WIRING AND CONNECTORS

| TEST | ACTION | APPLICABILITY |
|------|--|---------------|
| 1 | <p>NOTE: Low fluid level can be the cause of many Transmission problems. If the fluid level is low, locate and repair the leak, then check and adjust the fluid level per the Service Information.</p> <p>NOTE: Always perform diagnostics with a fully charged battery to avoid false symptoms.</p> <p>With the DRBIII®, read the engine DTC's. Check and repair all engine DTC's prior to performing Transmission Symptom Diagnostics.</p> <p>With the DRBIII®, read Transmission DTC's. Record all DTC's and 1 Trip Failures.</p> <p>NOTE: Diagnose 1 Trip Failures as a fully matured DTC.</p> <p>Using the wiring diagram/schematic as a guide, inspect the wiring and connectors. Repair as necessary.</p> <p>Perform the Shift Lever Position Test. If the test does not pass, refer to Symptom test for P0706 Check Shifter Signal.</p> <p>For Gear Ratio DTC's, check and record all CVI's.</p> <p>Most DTC's set on start up but some must be set by driving the vehicle such that all diagnostic monitors have run.</p> <p>NOTE: Verify flash level of Transmission Control Module. Some problems are corrected by software upgrades to the Transmission Control Module.</p> <p>NOTE: Check for applicable TSB's related to the symptom.</p> <p>Perform this procedure prior to Symptom diagnosis.</p> <p>Continue Go To 2</p> | All |
| 2 | <p>Ignition on, engine not running.</p> <p>With the DRBIII®, read Transmission DTC's</p> <p>Is the DTC P0750 and/or P0841 present also?</p> <p>Yes → Refer to the Transmission category and perform the appropriate symptom. Perform 42RLE TRANSMISSION VERIFICATION TEST - VER 1.</p> <p>No → Go To 3</p> | All |

P0740-TORQUE CONVERTER CLUTCH CONTROL CIRCUIT — Continued

| TEST | ACTION | APPLICABILITY |
|------|---|---------------|
| 3 | <p>Ignition on, engine not running. With the DRBIII®, record and erase Transmission DTCs. Drive the vehicle until it is fully warmed up to at least 43° C or 110° F. Perform the following steps 3 times. With the DRBIII®, monitor TPS degree. Drive the vehicle to the speed of 83 Km/h or 50 MPH and allow 4th gear to engage for at least 10 seconds. Close the throttle, then tip back in until the throttle angle, TPS degrees, is between 25 and 29 degrees. NOTE: If you go over 30 TPS degrees, you must back off of the throttle and retry. Did the TCC engage during any of the attempts?</p> <p style="padding-left: 40px;">Yes → Go To 4</p> <p style="padding-left: 40px;">No → Go To 5</p> | All |
| 4 | <p>The conditions necessary to set the DTC are not present at this time. Using the schematics as a guide, inspect the wiring and connectors specific to this circuit. Wiggle the wires while checking for shorts and open circuits. This DTC can also be set under extreme temperature conditions, this is usually caused by an internal problem. Verify if the problem is only experienced under extreme hot or cold conditions. With the DRBIII®, check the EATX EVENT DATA to help identify the conditions in which the DTC was set. Were there any problems found?</p> <p style="padding-left: 40px;">Yes → Repair as necessary. Perform 42RLE TRANSMISSION VERIFICATION TEST - VER 1.</p> <p style="padding-left: 40px;">No → Test Complete.</p> | All |
| 5 | <p>If there are no possible causes remaining, view repair.</p> <p style="padding-left: 40px;">Repair</p> <p style="padding-left: 80px;">Perform the Hydraulic Pressure test in the Service Information. Repair the internal transmission components and torque converter per the Service Information. Perform 42RLE TRANSMISSION VERIFICATION TEST - VER 1.</p> | All |

Symptom:

P0750-LR SOLENOID CIRCUIT

When Monitored and Set Condition:

P0750-LR SOLENOID CIRCUIT

When Monitored: Initially at power-up, then every 10 seconds thereafter. The solenoids will also be tested immediately after a Gear Ratio or Pressure Switch error is detected.

Set Condition: Three consecutive solenoid continuity test failures, or one failure if a test is run in response to a Gear Ratio or Pressure Switch error.

POSSIBLE CAUSES

- RELATED RELAY DTC'S PRESENT
- TRANSMISSION CONTROL RELAY OUTPUT CIRCUIT OPEN
- L/R SOLENOID CONTROL CIRCUIT OPEN
- L/R SOLENOID CONTROL CIRCUIT SHORT TO GROUND
- L/R SOLENOID CONTROL CIRCUIT SHORT TO VOLTAGE
- L/R SOLENOID
- TRANSMISSION CONTROL MODULE
- INTERMITTENT WIRING AND CONNECTORS

| TEST | ACTION | APPLICABILITY |
|------|--|---------------|
| 1 | <p>NOTE: Low fluid level can be the cause of many Transmission problems. If the fluid level is low, locate and repair the leak, then check and adjust the fluid level per the Service Information.</p> <p>NOTE: Always perform diagnostics with a fully charged battery to avoid false symptoms.</p> <p>With the DRBIII®, read the engine DTC's. Check and repair all engine DTC's prior to performing Transmission Symptom Diagnostics.</p> <p>With the DRBIII®, read Transmission DTC's. Record all DTC's and 1 Trip Failures.</p> <p>NOTE: Diagnose 1 Trip Failures as a fully matured DTC.</p> <p>Using the wiring diagram/schematic as a guide, inspect the wiring and connectors. Repair as necessary.</p> <p>Perform the Shift Lever Position Test. If the test does not pass, refer to Symptom test for P0706 Check Shifter Signal.</p> <p>For Gear Ratio DTC's, check and record all CVT's.</p> <p>Most DTC's set on start up but some must be set by driving the vehicle such that all diagnostic monitors have run.</p> <p>NOTE: Verify flash level of Transmission Control Module. Some problems are corrected by software upgrades to the Transmission Control Module.</p> <p>NOTE: Check for applicable TSB's related to the symptom.</p> <p>Perform this procedure prior to Symptom diagnosis.</p> <p style="text-align: center;">Continue Go To 2</p> | All |

P0750-LR SOLENOID CIRCUIT — Continued

| TEST | ACTION | APPLICABILITY |
|------|---|---------------|
| 2 | Ignition on, engine not running. With the DRBIII®, read Transmission DTC's Are there any Transmission Control Relay DTC's present? Yes → Refer to symptom list and perform the appropriate symptom for Transmission Control Relay related DTC's. Perform 42RLE TRANSMISSION VERIFICATION TEST - VER 1. No → Go To 3 | All |
| 3 | With the DRBIII®, Check the STARTS SINCE SET counter for P0750. NOTE: This counter only applies to the last DTC set. Is the STARTS SINCE SET counter for P0750 set at 0? Yes → Go To 4 No → Go To 11 | All |
| 4 | Turn the ignition off to the lock position. CAUTION: Remove the Starter Relay from the PDC. This will prevent the vehicle from being started in gear. Install the Transmission Simulator, Miller tool #8333 and the Electronic Transmission Adapter kit 8333-1. Ignition on, engine not running. With the DRBIII®, actuate the L/R Solenoid. With the Transmission Simulator, monitor the L/R Solenoid LED. Did the L/R Solenoid LED on the Transmission Simulator blink on and off during actuation? Yes → Go To 5 No → Go To 6 | All |
| 5 | If there are no possible causes remaining, view repair. Repair Replace the Transmission Solenoid/Pressure Switch Assembly per the Service Information. Perform 42RLE TRANSMISSION VERIFICATION TEST - VER 1. | All |
| 6 | Turn the ignition off to the lock position. Disconnect the TCM harness connector. Disconnect the Transmission Solenoid/Pressure Switch Assembly harness connector. Measure the resistance of the L/R Solenoid Control circuit from the TCM harness connector to the Transmission Solenoid/Pressure Switch Assembly harness connector. Is the resistance above 5.0 ohms? Yes → Repair the L/R Solenoid Control circuit for an open. Perform 42RLE TRANSMISSION VERIFICATION TEST - VER 1. No → Go To 7 | All |

P0750-LR SOLENOID CIRCUIT — Continued

| TEST | ACTION | APPLICABILITY |
|------|--|---------------|
| 7 | <p>Turn the ignition off to the lock position. Disconnect the TCM harness connector. Disconnect the Transmission Solenoid/Pressure Switch Assembly harness connector. Measure the resistance between ground and the L/R Solenoid Control circuit. Is the resistance below 5.0 ohms?</p> <p>Yes → Repair the L/R Solenoid Control circuit for a short to ground. Perform 42RLE TRANSMISSION VERIFICATION TEST - VER 1.</p> <p>No → Go To 8</p> | All |
| 8 | <p>Turn the ignition off to the lock position. Disconnect the TCM harness connector. Disconnect the Transmission Solenoid/Pressure Switch Assembly harness connector. Remove the Transmission Control Relay from the PDC. Note: Check connectors - Clean/repair as necessary. Connect a jumper wire between the Fused B+ circuit and the Transmission Control Relay Output circuit in the Transmission Control Relay connector in the PDC. Ignition on, engine not running. Measure the voltage of the L/R Solenoid Control circuit. Is the voltage above 0.5 volt?</p> <p>Yes → Repair the L/R Solenoid Control circuit for a short to voltage. Perform 42RLE TRANSMISSION VERIFICATION TEST - VER 1.</p> <p>No → Go To 9</p> | All |
| 9 | <p>Turn the ignition off to the lock position. Disconnect the Transmission Solenoid/Pressure Switch Assembly harness connector. Remove the Transmission Control Relay from the PDC. Note: Check connectors - Clean/repair as necessary. Connect a jumper wire between the Fused B+ circuit and the Transmission Control Relay Output circuit in the Transmission Control Relay connector in the PDC. Ignition on, engine not running. Using a 12-volt test light connected to ground, check the Transmission Control Relay Output circuit. NOTE: The test light must illuminate brightly. Compare the brightness to that of a direct connection to the battery. Does the test light illuminate brightly?</p> <p>Yes → Go To 10</p> <p>No → Repair the Transmission Control Relay Output circuit for an open or high resistance. Perform 42RLE TRANSMISSION VERIFICATION TEST - VER 1.</p> | All |
| 10 | <p>Using the schematics as a guide, inspect the wiring and connectors. Repair as necessary. Pay particular attention to all power and ground circuits. If there are no possible causes remaining, view repair.</p> <p>Repair</p> <p>Replace the Transmission Control Module per the Service Information. WITH THE DRBIII® PERFORM QUICK LEARN. Perform 42RLE TRANSMISSION VERIFICATION TEST - VER 1.</p> | All |

P0750-LR SOLENOID CIRCUIT — Continued

| TEST | ACTION | APPLICABILITY |
|-------------|---|----------------------|
| 11 | <p>The conditions necessary to set this DTC are not present at this time. Using the schematics as a guide, inspect the wiring and connectors specific to this circuit. Wiggle the wiring while checking for shorts and open circuits. With the DRBIII®, check the EATX EVENT DATA to help identify the conditions in which the DTC was set. Were there any problems found?</p> <p>Yes → Repair as necessary. Perform 42RLE TRANSMISSION VERIFICATION TEST - VER 1.</p> <p>No → Test Complete.</p> | All |

Symptom:

P0755-2/4 SOLENOID CIRCUIT

When Monitored and Set Condition:

P0755-2/4 SOLENOID CIRCUIT

When Monitored: Initially at power-up, then every 10 seconds thereafter. They will also be tested immediately after a Gear Ratio or Pressure Switch error is detected.

Set Condition: Three consecutive Solenoid continuity test failures, or one failure if test is run in response to a Gear Ratio or Pressure Switch error.

POSSIBLE CAUSES

RELATED RELAY DTC'S PRESENT
 TRANSMISSION CONTROL RELAY OUTPUT CIRCUIT OPEN
 2/4 SOLENOID CONTROL CIRCUIT OPEN
 2/4 SOLENOID CONTROL CIRCUIT SHORT TO GROUND
 2/4 SOLENOID CONTROL CIRCUIT SHORT TO VOLTAGE
 2/4 SOLENOID
 TRANSMISSION CONTROL MODULE
 INTERMITTENT WIRING AND CONNECTORS

| TEST | ACTION | APPLICABILITY |
|------|--|---------------|
| 1 | <p>NOTE: Low fluid level can be the cause of many Transmission problems. If the fluid level is low, locate and repair the leak, then check and adjust the fluid level per the Service Information.</p> <p>NOTE: Always perform diagnostics with a fully charged battery to avoid false symptoms.</p> <p>With the DRBIII®, read the engine DTC's. Check and repair all engine DTC's prior to performing Transmission Symptom Diagnostics.</p> <p>With the DRBIII®, read Transmission DTC's. Record all DTC's and 1 Trip Failures.</p> <p>NOTE: Diagnose 1 Trip Failures as a fully matured DTC.</p> <p>Using the wiring diagram/schematic as a guide, inspect the wiring and connectors. Repair as necessary.</p> <p>Perform the Shift Lever Position Test. If the test does not pass, refer to Symptom test for P0706 Check Shifter Signal.</p> <p>For Gear Ratio DTC's, check and record all CVT's.</p> <p>Most DTC's set on start up but some must be set by driving the vehicle such that all diagnostic monitors have run.</p> <p>NOTE: Verify flash level of Transmission Control Module. Some problems are corrected by software upgrades to the Transmission Control Module.</p> <p>NOTE: Check for applicable TSB's related to the symptom.</p> <p>Perform this procedure prior to Symptom diagnosis.</p> <p>Continue Go To 2</p> | All |

P0755-2/4 SOLENOID CIRCUIT — Continued

| TEST | ACTION | APPLICABILITY |
|------|--|---------------|
| 2 | With the DRBIII®, read Transmission Control Module DTC's Are there any Transmission Control Relay DTC's present? Yes → Refer to symptom list and perform the appropriate symptom for Transmission Control Relay related DTC's. Perform 42RLE TRANSMISSION VERIFICATION TEST - VER 1. No → Go To 3 | All |
| 3 | With the DRBIII®, Check the STARTS SINCE SET counter. NOTE: This counter only applies to the last DTC set. Is the STARTS SINCE SET counter for P0755 set at 0? Yes → Go To 4 No → Go To 11 | All |
| 4 | Turn the ignition off to the lock position. CAUTION: Remove the Starter Relay from the PDC. This will prevent the vehicle from being started in gear. Install the Transmission Simulator, Miller tool #8333 and the Electronic Transmission Adapter kit 8333-1. Ignition on, engine not running. With the DRBIII®, actuate the 2/4 Solenoid. With the Transmission Simulator, monitor the 2/4 Solenoid LED. Did the 2/4 Solenoid LED on the Transmission Simulator blink on and off during actuation? Yes → Go To 5 No → Go To 6 | All |
| 5 | If there are no possible causes remaining, view repair. Repair Replace the Transmission Solenoid/Pressure Switch Assembly per the Service Information. Perform 42RLE TRANSMISSION VERIFICATION TEST - VER 1. | All |
| 6 | Turn the ignition off to the lock position. Disconnect the TCM harness connector. Disconnect the Transmission Solenoid/Pressure Switch Assembly harness connector. Note: Check connectors - Clean/repair as necessary. Measure the resistance of the 2/4 Solenoid Control circuit from the TCM harness connector to the Transmission Solenoid/Pressure Switch Assembly harness connector. Is the resistance above 5.0 ohms? Yes → Repair the 2/4 Solenoid Control circuit for an open. Perform 42RLE TRANSMISSION VERIFICATION TEST - VER 1. No → Go To 7 | All |

P0755-2/4 SOLENOID CIRCUIT — Continued

| TEST | ACTION | APPLICABILITY |
|------|---|---------------|
| 7 | <p>Turn the ignition off to the lock position. Disconnect the TCM harness connector. Disconnect the Transmission Solenoid/Pressure Switch Assembly harness connector. Note: Check connectors - Clean/repair as necessary. Measure the resistance between ground and the 2/4 Solenoid Control circuit. Is the resistance below 5.0 ohms?</p> <p>Yes → Repair the 2/4 Solenoid Control circuit for a short to ground. Perform 42RLE TRANSMISSION VERIFICATION TEST - VER 1.</p> <p>No → Go To 8</p> | All |
| 8 | <p>Turn the ignition off to the lock position. Disconnect the TCM harness connector. Disconnect the Transmission Solenoid/Pressure Switch Assembly harness connector. Remove the Transmission Control Relay from the PDC. Note: Check connectors - Clean/repair as necessary. Connect a jumper wire between the Fused B+ circuit and Transmission Control Relay Output circuit in the Transmission Control Relay connector in the PDC. Ignition on, engine not running. Measure the voltage of the 2/4 Solenoid Control circuit. Is the voltage above 0.5 volt?</p> <p>Yes → Repair the 2/4 Solenoid Control circuit for a short to voltage. Perform 42RLE TRANSMISSION VERIFICATION TEST - VER 1.</p> <p>No → Go To 9</p> | All |
| 9 | <p>Turn the ignition off to the lock position. Disconnect the Transmission Solenoid/Pressure Switch Assembly harness connector. Remove the Transmission Control Relay from the PDC. Note: Check connectors - Clean/repair as necessary. Connect a jumper wire between the Fused B+ circuit and the Transmission Control Relay Output circuit in the Transmission Control Relay connector. Ignition on, engine not running. Using a 12-volt test light connected to ground, check the Transmission Control Relay Output circuit. NOTE: The test light must illuminate brightly. Compare the brightness to that of a direct connection to the battery. Does the test light illuminate brightly?</p> <p>Yes → Go To 10</p> <p>No → Repair the Transmission Control Relay Output circuit for an open or high resistance. Perform 42RLE TRANSMISSION VERIFICATION TEST - VER 1.</p> | All |
| 10 | <p>Using the schematics as a guide, inspect the wiring and connectors. Repair as necessary. Pay particular attention to all power and ground circuits. If there are no possible causes remaining, view repair.</p> <p>Repair</p> <p>Replace the Transmission Control Module per the Service Information. WITH THE DRBIII® PERFORM QUICK LEARN. Perform 42RLE TRANSMISSION VERIFICATION TEST - VER 1.</p> | All |

P0755-2/4 SOLENOID CIRCUIT — Continued

| TEST | ACTION | APPLICABILITY |
|------|--|---------------|
| 11 | <p>The conditions necessary to set this DTC are not present at this time. Using the schematics as a guide, inspect the wiring and connectors specific to this circuit. Wiggle the wiring while checking for shorts and open circuits. With the DRBIII®, check the EATX EVENT DATA to help identify the conditions in which the DTC was set. Were there any problems found?</p> <p style="padding-left: 40px;">Yes → Repair as necessary. Perform 42RLE TRANSMISSION VERIFICATION TEST - VER 1.</p> <p style="padding-left: 40px;">No → Test Complete.</p> | All |

Symptom:

P0760-OD SOLENOID CIRCUIT

When Monitored and Set Condition:

P0760-OD SOLENOID CIRCUIT

When Monitored: Initially at power-up, then every 10 seconds thereafter. They will also be tested immediately after a Gear Ratio or Pressure Switch error is detected.

Set Condition: Three consecutive solenoid continuity test failures, or one failure if test is run in response to a Gear Ratio or Pressure Switch error.

POSSIBLE CAUSES

- RELATED RELAY DTC'S PRESENT
- INTERMITTENT WIRING AND CONNECTORS
- TRANSMISSION CONTROL RELAY OUTPUT CIRCUIT OPEN
- OD SOLENOID CONTROL CIRCUIT OPEN
- OD SOLENOID CONTROL CIRCUIT SHORT TO GROUND
- OD SOLENOID CONTROL CIRCUIT SHORT TO VOLTAGE
- OD SOLENOID
- TRANSMISSION CONTROL MODULE

| TEST | ACTION | APPLICABILITY |
|------|--|---------------|
| 1 | <p>NOTE: Low fluid level can be the cause of many Transmission problems. If the fluid level is low, locate and repair the leak, then check and adjust the fluid level per the Service Information.</p> <p>NOTE: Always perform diagnostics with a fully charged battery to avoid false symptoms.</p> <p>With the DRBIII®, read the engine DTC's. Check and repair all engine DTC's prior to performing Transmission Symptom Diagnostics.</p> <p>With the DRBIII®, read Transmission DTC's. Record all DTC's and 1 Trip Failures.</p> <p>NOTE: Diagnose 1 Trip Failures as a fully matured DTC.</p> <p>Using the wiring diagram/schematic as a guide, inspect the wiring and connectors. Repair as necessary.</p> <p>Perform the Shift Lever Position Test. If the test does not pass, refer to Symptom test for P0706 Check Shifter Signal.</p> <p>For Gear Ratio DTC's, check and record all CVT's.</p> <p>Most DTC's set on start up but some must be set by driving the vehicle such that all diagnostic monitors have run.</p> <p>NOTE: Verify flash level of Transmission Control Module. Some problems are corrected by software upgrades to the Transmission Control Module.</p> <p>NOTE: Check for applicable TSB's related to the symptom.</p> <p>Perform this procedure prior to Symptom diagnosis.</p> <p style="text-align: center;">Continue Go To 2</p> | All |

P0760-OD SOLENOID CIRCUIT — Continued

| TEST | ACTION | APPLICABILITY |
|------|---|---------------|
| 2 | <p>With the DRBIII®, read Transmission Control Module DTC's Are there any Transmission Control Relay DTC's present?</p> <p>Yes → Refer to the Transmission category and perform the appropriate symptom. Perform 42RLE TRANSMISSION VERIFICATION TEST - VER 1.</p> <p>No → Go To 3</p> | All |
| 3 | <p>With the DRBIII®, Check the STARTS SINCE SET counter for P0760. NOTE: This counter only applies to the last DTC set. Is the STARTS SINCE SET counter for P0760 set at 0?</p> <p>Yes → Go To 4</p> <p>No → Go To 11</p> | All |
| 4 | <p>Turn the ignition off to the lock position. CAUTION: Remove the Starter Relay from the PDC. This will prevent the vehicle from being started in gear. Install the Transmission Simulator, Miller tool #8333 and the Electronic Transmission Adapter kit 8333-1. Ignition on, engine not running. With the Transmission Simulator, monitor the OD Solenoid LED. With the DRBIII®, actuate the OD Solenoid. Did the OD Solenoid LED on the Transmission Simulator blink on and off during actuation?</p> <p>Yes → Go To 5</p> <p>No → Go To 6</p> | All |
| 5 | <p>If there are no possible causes remaining, view repair.</p> <p>Repair Replace the Transmission Solenoid/Pressure Switch Assembly per the Service Information. Perform 42RLE TRANSMISSION VERIFICATION TEST - VER 1.</p> | All |
| 6 | <p>Turn the ignition off to the lock position. Disconnect the TCM harness connector. Disconnect the Transmission Solenoid/Pressure Switch Assembly harness connector. Note: Check connectors - Clean/repair as necessary. Measure the resistance of the OD Solenoid Control circuit from the TCM harness connector to the Transmission Solenoid/Pressure Switch Assembly harness connector. Is the resistance above 5.0 ohms?</p> <p>Yes → Repair the OD Solenoid Control circuit for an open. Perform 42RLE TRANSMISSION VERIFICATION TEST - VER 1.</p> <p>No → Go To 7</p> | All |

P0760-OD SOLENOID CIRCUIT — Continued

| TEST | ACTION | APPLICABILITY |
|------|--|---------------|
| 7 | <p>Turn the ignition off to the lock position. Disconnect the TCM harness connector. Disconnect the Transmission Solenoid/Pressure Switch Assembly harness connector. Note: Check connectors - Clean/repair as necessary. Measure the resistance between ground and the OD Solenoid Control circuit. Is the resistance below 5.0 ohms?</p> <p style="padding-left: 40px;">Yes → Repair the OD Solenoid Control circuit for a short to ground. Perform 42RLE TRANSMISSION VERIFICATION TEST - VER 1.</p> <p style="padding-left: 40px;">No → Go To 8</p> | All |
| 8 | <p>Turn the ignition off to the lock position. Disconnect the TCM harness connector. Disconnect the Transmission Solenoid/Pressure Switch Assembly harness connector. Remove the Transmission Control Relay from the PDC. Note: Check connectors - Clean/repair as necessary. Connect a jumper wire between the Fused B+ circuit and the Transmission Control Relay Output circuit in the Transmission Control Relay connector in the PDC. Ignition on, engine not running. Measure the voltage of the OD Solenoid Control circuit. Is the voltage above 0.5 volt?</p> <p style="padding-left: 40px;">Yes → Repair the OD Solenoid Control circuit for a short to voltage. Perform 42RLE TRANSMISSION VERIFICATION TEST - VER 1.</p> <p style="padding-left: 40px;">No → Go To 9</p> | All |
| 9 | <p>Turn the ignition off to the lock position. Disconnect the Transmission Solenoid/Pressure Switch Assembly harness connector. Remove the Transmission Control Relay from the PDC. Note: Check connectors - Clean/repair as necessary. Connect a jumper wire between the Fused B+ circuit and the Transmission Control Relay Output circuit in the Transmission Control Relay connector in the PDC. Ignition on, engine not running. Using a 12-volt test light connected to ground, check the Transmission Control Relay Output circuit. NOTE: The test light must illuminate brightly. Compare the brightness to that of a direct connection to the battery. Does the test light illuminate brightly?</p> <p style="padding-left: 40px;">Yes → Go To 10</p> <p style="padding-left: 40px;">No → Repair the Transmission Control Relay Output circuit for an open or high resistance. Perform 42RLE TRANSMISSION VERIFICATION TEST - VER 1.</p> | All |
| 10 | <p>Using the schematics as a guide, inspect the wiring and connectors. Repair as necessary. Pay particular attention to all power and ground circuits. If there are no possible causes remaining, view repair.</p> <p style="padding-left: 40px;">Repair</p> <p style="padding-left: 80px;">Replace the Transmission Control Module per the Service Information. WITH THE DRBIII® PERFORM QUICK LEARN. Perform 42RLE TRANSMISSION VERIFICATION TEST - VER 1.</p> | All |

P0760-OD SOLENOID CIRCUIT — Continued

| TEST | ACTION | APPLICABILITY |
|------|--|---------------|
| 11 | <p>The conditions necessary to set this DTC are not present at this time. Using the schematics as a guide, inspect the wiring and connectors specific to this circuit. Wiggle the wiring while checking for shorts and open circuits. With the DRBIII®, check the EATX EVENT DATA to help identify the conditions in which the DTC was set. Were there any problems found?</p> <p>Yes → Repair as necessary. Perform 42RLE TRANSMISSION VERIFICATION TEST - VER 1.</p> <p>No → Test Complete.</p> | All |

Symptom:

P0765-UD SOLENOID CIRCUIT

When Monitored and Set Condition:

P0765-UD SOLENOID CIRCUIT

When Monitored: Initially at power-up, then every 10 seconds thereafter. They will also be tested immediately after a Gear Ratio or Pressure Switch error is detected.

Set Condition: Three consecutive Solenoid continuity test failures, or one failure if test is run in response to a Gear Ratio or Pressure Switch error.

POSSIBLE CAUSES

RELATED RELAY DTC'S PRESENT
 TRANSMISSION CONTROL RELAY OUTPUT CIRCUIT OPEN
 UD SOLENOID CONTROL CIRCUIT OPEN
 UD SOLENOID CONTROL CIRCUIT SHORT TO GROUND
 UD SOLENOID CONTROL CIRCUIT SHORT TO VOLTAGE
 UD SOLENOID
 TRANSMISSION CONTROL MODULE
 INTERMITTENT WIRING AND CONNECTORS

| TEST | ACTION | APPLICABILITY |
|------|--|---------------|
| 1 | <p>NOTE: Low fluid level can be the cause of many Transmission problems. If the fluid level is low, locate and repair the leak, then check and adjust the fluid level per the Service Information.</p> <p>NOTE: Always perform diagnostics with a fully charged battery to avoid false symptoms.</p> <p>With the DRBIII®, read the engine DTC's. Check and repair all engine DTC's prior to performing Transmission Symptom Diagnostics.</p> <p>With the DRBIII®, read Transmission DTC's. Record all DTC's and 1 Trip Failures.</p> <p>NOTE: Diagnose 1 Trip Failures as a fully matured DTC.</p> <p>Using the wiring diagram/schematic as a guide, inspect the wiring and connectors. Repair as necessary.</p> <p>Perform the Shift Lever Position Test. If the test does not pass, refer to Symptom test for P0706 Check Shifter Signal.</p> <p>For Gear Ratio DTC's, check and record all CVT's.</p> <p>Most DTC's set on start up but some must be set by driving the vehicle such that all diagnostic monitors have run.</p> <p>NOTE: Verify flash level of Transmission Control Module. Some problems are corrected by software upgrades to the Transmission Control Module.</p> <p>NOTE: Check for applicable TSB's related to the symptom.</p> <p>Perform this procedure prior to Symptom diagnosis.</p> <p>Continue Go To 2</p> | All |

P0765-UD SOLENOID CIRCUIT — Continued

| TEST | ACTION | APPLICABILITY |
|------|---|---------------|
| 2 | <p>With the DRBIII®, read Transmission Control Module DTC's Are there any Transmission Control Relay DTC's present?</p> <p>Yes → Refer to the Transmission category and perform the appropriate symptom. Perform 42RLE TRANSMISSION VERIFICATION TEST - VER 1.</p> <p>No → Go To 3</p> | All |
| 3 | <p>With the DRBIII®, Check the STARTS SINCE SET counter. NOTE: This counter only applies to the last DTC set. Is the STARTS SINCE SET counter for P0765 set at 0?</p> <p>Yes → Go To 4</p> <p>No → Go To 11</p> | All |
| 4 | <p>Turn the ignition off to the lock position. CAUTION: Remove the Starter Relay from the PDC. This will prevent the vehicle from being started in gear. Install the Transmission Simulator, Miller tool #8333 and the Electronic Transmission Adapter kit 8333-1. Ignition on, engine not running. With the DRBIII®, actuate the UD Solenoid. With the Transmission Simulator, monitor the UD Solenoid LED. Did the UD Solenoid LED on the Transmission Simulator blink on and off?</p> <p>Yes → Go To 5</p> <p>No → Go To 6</p> | All |
| 5 | <p>If there are no possible causes remaining, view repair.</p> <p>Repair Replace Transmission Solenoid/Pressure Switch Assembly per the Service Information. Perform 42RLE TRANSMISSION VERIFICATION TEST - VER 1.</p> | All |
| 6 | <p>Turn the ignition off to the lock position. Disconnect the TCM harness connector. Disconnect the Transmission Solenoid/Pressure Switch Assembly harness connector. Note: Check connectors - Clean/repair as necessary. Measure the resistance of the UD Solenoid Control circuit from the TCM harness connector to the Transmission Solenoid/Pressure Switch Assembly harness connector. Is the resistance above 5.0 ohms?</p> <p>Yes → Repair the UD Solenoid Control circuit for an open. Perform 42RLE TRANSMISSION VERIFICATION TEST - VER 1.</p> <p>No → Go To 7</p> | All |

P0765-UD SOLENOID CIRCUIT — Continued

| TEST | ACTION | APPLICABILITY |
|------|--|---------------|
| 7 | <p>Turn the ignition off to the lock position. Disconnect the TCM harness connector. Disconnect the Transmission Solenoid/Pressure Switch Assembly harness connector. Note: Check connectors - Clean/repair as necessary. Measure the resistance between ground and the UD Solenoid Control circuit. Is the resistance below 5.0 ohms?</p> <p>Yes → Repair the UD Solenoid Control circuit for a short to ground. Perform 42RLE TRANSMISSION VERIFICATION TEST - VER 1.</p> <p>No → Go To 8</p> | All |
| 8 | <p>Turn the ignition off to the lock position. Disconnect the TCM harness connector. Disconnect the Transmission Solenoid/Pressure Switch Assembly harness connector. Remove the Transmission Control Relay from the PDC. Connect a jumper wire between the Fused B+ circuits and Transmission Control Relay Output circuit in the Transmission Control Relay connector. Ignition on, engine not running. Note: Check connectors - Clean/repair as necessary. Measure the voltage of the UD Solenoid Control circuit. Is the voltage above 0.5 volt?</p> <p>Yes → Repair the UD Solenoid Control circuit for a short to voltage. Perform 42RLE TRANSMISSION VERIFICATION TEST - VER 1.</p> <p>No → Go To 9</p> | All |
| 9 | <p>Turn the ignition off to the lock position. Disconnect the Transmission Solenoid/Pressure Switch Assembly harness connector. Remove the Transmission Control Relay. Note: Check connectors - Clean/repair as necessary. Connect a jumper wire between the Fused B+ circuit and Transmission Control Relay Output circuit in the Transmission Control Relay connector. Ignition on, engine not running. Using a 12-volt test light connected to ground, check the Transmission Control Relay Output circuit. NOTE: The test light must illuminate brightly. Compare the brightness to that of a direct connection to the battery. Does the test light illuminate brightly?</p> <p>Yes → Go To 10</p> <p>No → Repair the Transmission Control Relay Output circuit for an open or high resistance. Perform 42RLE TRANSMISSION VERIFICATION TEST - VER 1.</p> | All |
| 10 | <p>Using the schematics as a guide, inspect the wiring and connectors. Repair as necessary. Pay particular attention to all power and ground circuits. If there are no possible causes remaining, view repair.</p> <p>Repair</p> <p>Replace the Transmission Control Module per the Service Information. WITH THE DRBIII® PERFORM QUICK LEARN. Perform 42RLE TRANSMISSION VERIFICATION TEST - VER 1.</p> | All |

P0765-UD SOLENOID CIRCUIT — Continued

| TEST | ACTION | APPLICABILITY |
|------|--|---------------|
| 11 | <p>The conditions necessary to set this DTC are not present at this time. Using the schematics as a guide, inspect the wiring and connectors specific to this circuit. Wiggle the wiring while checking for shorts and open circuits. With the DRBIII®, check the EATX EVENT DATA to help identify the conditions in which the DTC was set. Were there any problems found?</p> <p>Yes → Repair as necessary. Perform 42RLE TRANSMISSION VERIFICATION TEST - VER 1.</p> <p>No → Test Complete.</p> | All |

Symptom:

P0841-LR PRESSURE SWITCH SENSE CIRCUIT

When Monitored and Set Condition:

P0841-LR PRESSURE SWITCH SENSE CIRCUIT

When Monitored: Whenever the engine is running.

Set Condition: The appropriate DTC is set if one of the Pressure Switches are open or closed at the wrong time in a given gear .

POSSIBLE CAUSES

LOSS OF PRIME DTC P0944 PRESENT
 TRANSMISSION CONTROL RELAY DTCS PRESENT
 TCM AND WIRING
 TRANSMISSION CONTROL RELAY OUTPUT CIRCUIT OPEN
 L/R PRESSURE SWITCH SENSE CIRCUIT OPEN
 L/R PRESSURE SWITCH SENSE CIRCUIT SHORT TO GROUND
 L/R PRESSURE SWITCH SENSE CIRCUIT SHORT TO VOLTAGE
 TRANSMISSION CONTROL MODULE
 INTERMITTENT WIRING AND CONNECTORS

| TEST | ACTION | APPLICABILITY |
|------|--|---------------|
| 1 | <p>NOTE: Low fluid level can be the cause of many Transmission problems. If the fluid level is low, locate and repair the leak, then check and adjust the fluid level per the Service Information.</p> <p>NOTE: Always perform diagnostics with a fully charged battery to avoid false symptoms.</p> <p>With the DRBIII®, read the engine DTC's. Check and repair all engine DTC's prior to performing Transmission Symptom Diagnostics.</p> <p>With the DRBIII®, read Transmission DTC's. Record all DTC's and 1 Trip Failures.</p> <p>NOTE: Diagnose 1 Trip Failures as a fully matured DTC.</p> <p>Using the wiring diagram/schematic as a guide, inspect the wiring and connectors. Repair as necessary.</p> <p>Perform the Shift Lever Position Test. If the test does not pass, refer to Symptom test for P0706 Check Shifter Signal.</p> <p>For Gear Ratio DTC's, check and record all CVI's.</p> <p>Most DTC's set on start up but some must be set by driving the vehicle such that all diagnostic monitors have run.</p> <p>NOTE: Verify flash level of Transmission Control Module. Some problems are corrected by software upgrades to the Transmission Control Module.</p> <p>NOTE: Check for applicable TSB's related to the symptom.</p> <p>Perform this procedure prior to Symptom diagnosis.</p> <p style="text-align: center;">Continue Go To 2</p> | All |

P0841-LR PRESSURE SWITCH SENSE CIRCUIT — Continued

| TEST | ACTION | APPLICABILITY |
|------|--|---------------|
| 2 | <p>With the DRBIII®, check for other Transmission DTC's. Is the DTC P0944 present also?</p> <p>Yes → Refer to the Transmission category and perform the appropriate symptom. Perform 42RLE TRANSMISSION VERIFICATION TEST - VER 1.</p> <p>No → Go To 3</p> | All |
| 3 | <p>With the DRBIII®, read Transmission DTC's Are there any Transmission Control Relay DTC's present also?</p> <p>Yes → Refer to the Transmission category and perform the appropriate symptom. Perform 42RLE TRANSMISSION VERIFICATION TEST - VER 1.</p> <p>No → Go To 4</p> | All |
| 4 | <p>With the DRBIII®, Check the STARTS SINCE SET counter for P0841. NOTE: This counter only applies to the last DTC set. Is the STARTS SINCE SET counter 2 or less?</p> <p>Yes → Go To 5</p> <p>No → Go To 11</p> | All |
| 5 | <p>Turn the ignition off to the lock position. CAUTION: Remove the Starter Relay from the PDC. This will prevent the vehicle from being started in gear. Install the Transmission Simulator, Miller tool #8333 and the Electronic Transmission Adapter kit 8333-1. Note: Check connectors - Clean/repair as necessary. Ignition on, engine not running. On the Transmission Simulator select L/R on the Pressure Switch selector switch. With the DRBIII®, monitor the L/R Pressure Switch state while pressing the Pressure Switch Test button on the Transmission Simulator. Did the Pressure Switch state change from OPEN to CLOSED when the test button was pressed?</p> <p>Yes → Replace the Transmission Solenoid/Pressure Switch Assembly per the Service Information. Perform 42RLE TRANSMISSION VERIFICATION TEST - VER 1.</p> <p>No → Go To 6</p> | All |
| 6 | <p>Turn the ignition off to the lock position. Disconnect the TCM harness connector. Disconnect the Transmission Solenoid/Pressure Switch Assembly harness connector. Note: Check connectors - Clean/repair as necessary. Measure the resistance of the L/R Pressure Switch Sense circuit from the TCM harness connector to the Transmission Solenoid/Pressure Switch Assembly harness connector. Is the resistance above 5.0 ohms?</p> <p>Yes → Repair the L/R Pressure Switch Sense circuit for an open. Perform 42RLE TRANSMISSION VERIFICATION TEST - VER 1.</p> <p>No → Go To 7</p> | All |

P0841-LR PRESSURE SWITCH SENSE CIRCUIT — Continued

| TEST | ACTION | APPLICABILITY |
|------|--|---------------|
| 7 | <p>Turn the ignition off to the lock position. Disconnect the TCM harness connector. Disconnect the Transmission Solenoid/Pressure Switch Assembly harness connector. Note: Check connectors - Clean/repair as necessary. Measure the resistance between ground and the L/R Pressure Switch Sense circuit. Is the resistance below 5.0 ohms?</p> <p style="padding-left: 40px;">Yes → Repair the L/R Pressure Switch circuit for a short to ground. Perform 42RLE TRANSMISSION VERIFICATION TEST - VER 1.</p> <p style="padding-left: 40px;">No → Go To 8</p> | All |
| 8 | <p>Turn the ignition off to the lock position. Disconnect the TCM harness connector. Disconnect the Transmission Solenoid/Pressure Switch Assembly harness connector. Remove the Transmission Control Relay from the PDC. Note: Check connectors - Clean/repair as necessary. Connect a jumper wire between the Fused B+ circuit and Transmission Control Relay Output circuit in the Transmission Control Relay connector. Ignition on, engine not running. Measure the voltage of the L/R Pressure Switch Sense circuit. Is the voltage above 0.5 volt?</p> <p style="padding-left: 40px;">Yes → Repair the L/R Pressure Switch Sense circuit for a short to voltage. Perform 42RLE TRANSMISSION VERIFICATION TEST - VER 1.</p> <p style="padding-left: 40px;">No → Go To 9</p> | All |
| 9 | <p>Turn the ignition off to the lock position. Disconnect the Transmission Solenoid/Pressure Switch Assembly harness connector. Remove the Transmission Control Relay from the PDC. Note: Check connectors - Clean/repair as necessary. Connect a jumper wire between the Fused B+ circuit and Transmission Control Relay Output circuit in the Transmission Control Relay connector. Using a 12-volt test light connected to ground, check the Transmission Control Relay Output circuit in the Solenoid/Pressure Switch Assembly harness connector. NOTE: The test light must illuminate brightly. Compare the brightness to that of a direct connection to the battery. Does the test light illuminate brightly?</p> <p style="padding-left: 40px;">Yes → Go To 10</p> <p style="padding-left: 40px;">No → Repair the Transmission Control Relay Output circuit for an open or high resistance. If the fuse is open make sure to check for a short to ground. Perform 42RLE TRANSMISSION VERIFICATION TEST - VER 1.</p> | All |
| 10 | <p>Using the schematics as a guide, inspect the wiring and connectors. Repair as necessary. Pay particular attention to all power and ground circuits. If there are no possible causes remaining, view repair</p> <p style="padding-left: 40px;">Repair</p> <p style="padding-left: 80px;">Replace the Transmission Control Module per the Service Information. WITH THE DRBIII® PERFORM QUICK LEARN. Perform 42RLE TRANSMISSION VERIFICATION TEST - VER 1.</p> | All |

P0841-LR PRESSURE SWITCH SENSE CIRCUIT — Continued

| TEST | ACTION | APPLICABILITY |
|-------------|---|----------------------|
| 11 | <p>The conditions necessary to set this DTC are not present at this time. Using the schematics as a guide, inspect the wiring and connectors specific to this circuit. Wiggle the wiring while checking for shorts and open circuits. With the DRBIII®, check the EATX EVENT DATA to help identify the conditions in which the DTC was set. Were there any problems found?</p> <p>Yes → Repair as necessary. Perform 42RLE TRANSMISSION VERIFICATION TEST - VER 1.</p> <p>No → Test Complete.</p> | All |

Symptom:

P0845-2/4 HYDRAULIC PRESSURE TEST FAILURE

When Monitored and Set Condition:

P0845-2/4 HYDRAULIC PRESSURE TEST FAILURE

When Monitored: In any forward gear with engine speed above 1000 RPM shortly after a shift and every minute thereafter.

Set Condition: After a shift into a forward gear, with engine speed > 1000 RPM, the TCM momentarily turns on element pressure to the clutch ckts that don't have pressure to identify the correct pressure sw closes. If the pressure sw does not close 2 times the code sets.

POSSIBLE CAUSES

LOSS OF PRIME P0944 PRESENT

RELATED DTC'S PRESENT

TRANSMISSION CONTROL RELAY OUTPUT CIRCUIT OPEN

2/4 PRESSURE SWITCH SENSE CIRCUIT OPEN

2/4 PRESSURE SWITCH SENSE CIRCUIT SHORT TO GROUND

2/4 PRESSURE SWITCH SENSE CIRCUIT SHORT TO VOLTAGE

INTERNAL TRANSMISSION

TRANSMISSION CONTROL MODULE

INTERMITTENT WIRING AND CONNECTORS

P0845-2/4 HYDRAULIC PRESSURE TEST FAILURE — Continued

| TEST | ACTION | APPLICABILITY |
|------|--|---------------|
| 1 | <p>NOTE: Low fluid level can be the cause of many Transmission problems. If the fluid level is low, locate and repair the leak, then check and adjust the fluid level per the Service Information.</p> <p>NOTE: Always perform diagnostics with a fully charged battery to avoid false symptoms.</p> <p>With the DRBIII®, read the engine DTC's. Check and repair all engine DTC's prior to performing Transmission Symptom Diagnostics.</p> <p>With the DRBIII®, read Transmission DTC's. Record all DTC's and 1 Trip Failures.</p> <p>NOTE: Diagnose 1 Trip Failures as a fully matured DTC.</p> <p>Using the wiring diagram/schematic as a guide, inspect the wiring and connectors. Repair as necessary.</p> <p>Perform the Shift Lever Position Test. If the test does not pass, refer to Symptom test for P0706 Check Shifter Signal.</p> <p>For Gear Ratio DTC's, check and record all CVI's.</p> <p>Most DTC's set on start up but some must be set by driving the vehicle such that all diagnostic monitors have run.</p> <p>NOTE: Verify flash level of Transmission Control Module. Some problems are corrected by software upgrades to the Transmission Control Module.</p> <p>NOTE: Check for applicable TSB's related to the symptom.</p> <p>Perform this procedure prior to Symptom diagnosis.</p> <p style="text-align: center;">Continue Go To 2</p> | All |
| 2 | <p>With the DRBIII®, check for other Transmission DTCs.</p> <p>Is the DTC P0944 present also?</p> <p style="padding-left: 40px;">Yes → Refer to the Transmission category and perform the appropriate symptom. Perform 42RLE TRANSMISSION VERIFICATION TEST - VER 1.</p> <p style="padding-left: 40px;">No → Go To 3</p> | All |
| 3 | <p>With the DRBIII®, read Transmission DTC's.</p> <p>Is the DTC P0732, P0734 and/or P0846 present also?</p> <p style="padding-left: 40px;">Yes → Repair internal transmission as necessary. Refer to the Service Information for the proper repair procedure for components related to the OD clutch. Perform 42RLE TRANSMISSION VERIFICATION TEST - VER 1.</p> <p style="padding-left: 40px;">No → Go To 4</p> | All |
| 4 | <p>With the DRBIII®, Check the STARTS SINCE SET counter for P0845.</p> <p>NOTE: This counter only applies to the last DTC set.</p> <p>Is the STARTS SINCE SET counter 2 or less?</p> <p style="padding-left: 40px;">Yes → Go To 5</p> <p style="padding-left: 40px;">No → Go To 12</p> | All |

P0845-2/4 HYDRAULIC PRESSURE TEST FAILURE — Continued

| TEST | ACTION | APPLICABILITY |
|------|---|---------------|
| 5 | <p>Turn the ignition off to the lock position. CAUTION: Remove the Starter Relay from the PDC. This will prevent the vehicle from being started in gear. Install the Transmission Simulator, Miller tool #8333 and the Electronic Transmission Adapter kit 8333-1. Note: Check connectors - Clean/repair as necessary. Ignition on, engine not running. With the Transmission Simulator, select "2/4" on the Pressure Switch rotary switch. With the DRBIII®, monitor the 2/4 Pressure Switch state while pressing the Pressure Switch Test button on the Transmission Simulator. Wiggle the wiring leading to the TCM while pressing the button. Did the 2-4 Pressure Switch state change to closed and remain closed while wiggling the wires?</p> <p>Yes → Go To 6 No → Go To 7</p> | All |
| 6 | <p>If there are no possible causes remaining, view repair.</p> <p>Repair</p> <p>Disassemble and inspect the Valve Body per the Service Information and repair or replace as necessary. If there are no problems found in the Valve Body, replace the Transmission Solenoid/Pressure Switch Assembly per the Service Information. Perform 42RLE TRANSMISSION VERIFICATION TEST - VER 1.</p> | All |
| 7 | <p>Turn the ignition off to the lock position. Disconnect the TCM harness connector. Disconnect the Transmission Solenoid/Pressure Switch Assembly harness connector. Note: Check connectors - Clean/repair as necessary. Measure the resistance of the 2/4 Pressure Switch Sense circuit from the TCM harness connector to the Transmission Solenoid/Pressure Switch Assembly harness connector. Is the resistance above 5.0 ohms?</p> <p>Yes → Repair the 2/4 Pressure Switch Sense circuit or an open. Perform 42RLE TRANSMISSION VERIFICATION TEST - VER 1.</p> <p>No → Go To 8</p> | All |
| 8 | <p>Turn the ignition off to the lock position. Disconnect the TCM harness connector. Disconnect the Transmission Solenoid/Pressure Switch Assembly harness connector. Note: Check connectors - Clean/repair as necessary. Measure the resistance between ground and the 2/4 Pressure Switch Sense circuit. Is the resistance below 5.0 ohms?</p> <p>Yes → Repair the 2/4 Pressure Switch Sense circuit for a short to ground. Perform 42RLE TRANSMISSION VERIFICATION TEST - VER 1.</p> <p>No → Go To 9</p> | All |

P0845-2/4 HYDRAULIC PRESSURE TEST FAILURE — Continued

| TEST | ACTION | APPLICABILITY |
|------|---|---------------|
| 9 | <p>Turn the ignition off to the lock position. Disconnect the TCM harness connector. Disconnect the Transmission Solenoid/Pressure Switch Assembly harness connector. Remove the Transmission Control Relay. Note: Check connectors - Clean/repair as necessary. Connect a jumper wire between the Fused B+ circuit and the Transmission Control Relay Output circuit in the Transmission Control Relay connector. Ignition on, engine not running. Measure the voltage of the 2/4 Pressure Switch Sense circuit. Is the voltage above 0.5 volt?</p> <p>Yes → Repair the 2/4 Pressure Switch Sense circuit for a short to voltage. Perform 42RLE TRANSMISSION VERIFICATION TEST - VER 1.</p> <p>No → Go To 10</p> | All |
| 10 | <p>Turn the ignition off to the lock position. Disconnect the Transmission Solenoid/Pressure Switch Assembly harness connector. Remove the Transmission Control Relay. Note: Check connectors - Clean/repair as necessary. Connect a jumper wire between the Fused B+ circuit and Transmission Control Relay Output circuit in the Transmission Control Relay connector in the PDC. Ignition on, engine not running. Using a 12-volt test light connected to ground, check the Transmission Control Relay Output circuit. NOTE: The test light must illuminate brightly. Compare the brightness to that of a direct connection to the battery. Does the test light illuminate brightly?</p> <p>Yes → Go To 11</p> <p>No → Repair the Transmission Control Relay Output circuit for an open or high resistance. If the fuse is open make sure to check for a short to ground. Perform 42RLE TRANSMISSION VERIFICATION TEST - VER 1.</p> | All |
| 11 | <p>Using the schematics as a guide, inspect the wiring and connectors. Repair as necessary. Pay particular attention to all power and ground circuits. If there are no possible causes remaining, view repair.</p> <p>Repair</p> <p>Replace the Transmission Control Module per the Service Information. WITH THE DRBIII® PERFORM QUICK LEARN. Perform 42RLE TRANSMISSION VERIFICATION TEST - VER 1.</p> | All |
| 12 | <p>The conditions necessary to set this DTC are not present at this time. Using the schematics as a guide, inspect the wiring and connectors specific to this circuit. Wiggle the wiring while checking for shorts and open circuits. With the DRBIII®, check the EATX EVENT DATA to help identify the conditions in which the DTC was set. Were there any problems found?</p> <p>Yes → Repair as necessary. Perform 42RLE TRANSMISSION VERIFICATION TEST - VER 1.</p> <p>No → Test Complete.</p> | All |

Symptom:

P0846-2/4 PRESSURE SWITCH SENSE CIRCUIT

When Monitored and Set Condition:

P0846-2/4 PRESSURE SWITCH SENSE CIRCUIT

When Monitored: Whenever the engine is running.

Set Condition: The appropriate DTC is set if one of the Pressure Switches are open or closed at the wrong time in a given gear .

POSSIBLE CAUSES

- TRANSMISSION RELAY DTC'S PRESENT
- TRANSMISSION CONTROL RELAY OUTPUT CIRCUIT OPEN
- 2/4 PRESSURE SWITCH SENSE CIRCUIT OPEN
- 2/4 PRESSURE SWITCH SENSE CIRCUIT SHORT TO GROUND
- 2/4 PRESSURE SWITCH SENSE CIRCUIT SHORT TO VOLTAGE
- 2/4 PRESSURE SWITCH
- TRANSMISSION CONTROL MODULE
- INTERMITTENT WIRING AND CONNECTORS

| TEST | ACTION | APPLICABILITY |
|------|--|---------------|
| 1 | <p>NOTE: Low fluid level can be the cause of many Transmission problems. If the fluid level is low, locate and repair the leak, then check and adjust the fluid level per the Service Information.</p> <p>NOTE: Always perform diagnostics with a fully charged battery to avoid false symptoms.</p> <p>With the DRBIII®, read the engine DTC's. Check and repair all engine DTC's prior to performing Transmission Symptom Diagnostics.</p> <p>With the DRBIII®, read Transmission DTC's. Record all DTC's and 1 Trip Failures.</p> <p>NOTE: Diagnose 1 Trip Failures as a fully matured DTC.</p> <p>Using the wiring diagram/schematic as a guide, inspect the wiring and connectors. Repair as necessary.</p> <p>Perform the Shift Lever Position Test. If the test does not pass, refer to Symptom test for P0706 Check Shifter Signal.</p> <p>For Gear Ratio DTC's, check and record all CVI's.</p> <p>Most DTC's set on start up but some must be set by driving the vehicle such that all diagnostic monitors have run.</p> <p>NOTE: Verify flash level of Transmission Control Module. Some problems are corrected by software upgrades to the Transmission Control Module.</p> <p>NOTE: Check for applicable TSB's related to the symptom.</p> <p>Perform this procedure prior to Symptom diagnosis.</p> <p style="text-align: center;">Continue Go To 2</p> | All |

P0846-2/4 PRESSURE SWITCH SENSE CIRCUIT — Continued

| TEST | ACTION | APPLICABILITY |
|------|--|---------------|
| 2 | <p>With the DRBIII®, read Transmission DTC's Are there any Transmission Control Relay DTC's present also?</p> <p>Yes → Refer to the Transmission category and perform the appropriate symptom. Perform 42RLE TRANSMISSION VERIFICATION TEST - VER 1.</p> <p>No → Go To 3</p> | All |
| 3 | <p>With the DRBIII®, Check the STARTS SINCE SET counter. NOTE: This counter only applies to the last DTC set. Is the STARTS SINCE SET counter 2 or less for P0846?</p> <p>Yes → Go To 4</p> <p>No → Go To 11</p> | All |
| 4 | <p>Turn the ignition off to the lock position. CAUTION: Remove the Starter Relay. This will prevent the vehicle from being started in gear. Install the Transmission Simulator, Miller tool #8333 and the Electronic Transmission Adapter kit 8333-1. Note: Check connectors - Clean/repair as necessary. Ignition on, engine not running. With the Transmission Simulator, select 2/4 on the Pressure Switch selector switch. With the DRBIII®, monitor the 2/4 Pressure Switch state while pressing the Pressure Switch Test button on the Transmission Simulator. Did the Pressure Switch state change from OPEN to CLOSED when the test button was pressed?</p> <p>Yes → Go To 5</p> <p>No → Go To 6</p> | All |
| 5 | <p>If there are no possible causes remaining, view repair.</p> <p>Repair Replace Transmission Solenoid/Pressure Switch Assembly per the Service Information. Perform 42RLE TRANSMISSION VERIFICATION TEST - VER 1.</p> | All |
| 6 | <p>Turn the ignition off to the lock position. Disconnect the TCM harness connector. Disconnect the Transmission Solenoid/Pressure Switch Assembly harness connector. Note: Check connectors - Clean/repair as necessary. Measure the resistance of the 2/4 Pressure Switch Sense circuit from the TCM harness connector to the Transmission Solenoid/Pressure Switch Assembly harness connector. Is the resistance above 5.0 ohms?</p> <p>Yes → Repair the 2/4 Pressure Switch Sense circuit for an open. Perform 42RLE TRANSMISSION VERIFICATION TEST - VER 1.</p> <p>No → Go To 7</p> | All |

P0846-2/4 PRESSURE SWITCH SENSE CIRCUIT — Continued

| TEST | ACTION | APPLICABILITY |
|------|--|---------------|
| 7 | <p>Turn the ignition off to the lock position. Disconnect the TCM harness connector. Disconnect the Transmission Solenoid/Pressure Switch Assembly harness connector. Note: Check connectors - Clean/repair as necessary. Measure the resistance between ground and the 2/4 Pressure Switch Sense circuit. Is the resistance below 5.0 ohms?</p> <p style="padding-left: 40px;">Yes → Repair the 2/4 Pressure Switch Sense circuit for a short to ground. Perform 42RLE TRANSMISSION VERIFICATION TEST - VER 1.</p> <p style="padding-left: 40px;">No → Go To 8</p> | All |
| 8 | <p>Turn the ignition off to the lock position. Disconnect the TCM harness connector. Disconnect the Transmission Solenoid/Pressure Switch Assembly harness connector. Remove the Transmission Control Relay. Note: Check connectors - Clean/repair as necessary. Connect a jumper wire between the Fused B+ circuit and the Transmission Control Relay Output circuit in the Transmission Control Relay connector. Ignition on, engine not running. Measure the voltage of the 2/4 Pressure Switch Sense circuit. Is the voltage above 0.5 volt?</p> <p style="padding-left: 40px;">Yes → Repair the 2/4 Pressure Switch Sense circuit for a short to voltage. Perform 42RLE TRANSMISSION VERIFICATION TEST - VER 1.</p> <p style="padding-left: 40px;">No → Go To 9</p> | All |
| 9 | <p>Turn the ignition off to the lock position. Disconnect the Transmission Solenoid/Pressure Switch Assembly harness connector. Remove the Transmission Control Relay. Note: Check connectors - Clean/repair as necessary. Connect a jumper wire between the Fused B+ circuit and the Transmission Control Relay Output circuit in the Transmission Control Relay connector. Ignition on, engine not running. Using a 12-volt test light connected to ground, check the Transmission Control Relay Output circuit. NOTE: The test light must illuminate brightly. Compare the brightness to that of a direct connection to the battery. Does the test light illuminate brightly?</p> <p style="padding-left: 40px;">Yes → Go To 10</p> <p style="padding-left: 40px;">No → Repair the Transmission Control Relay Output circuit for an open or high resistance. If the fuse is open make sure to check for a short to ground. Perform 42RLE TRANSMISSION VERIFICATION TEST - VER 1.</p> | All |
| 10 | <p>Using the schematics as a guide, inspect the wiring and connectors. Repair as necessary. Pay particular attention to all power and ground circuits. If there are no possible causes remaining, view repair.</p> <p style="padding-left: 40px;">Repair</p> <p style="padding-left: 80px;">Replace the Transmission Control Module per the Service Information. WITH THE DRBIII® PERFORM QUICK LEARN. Perform 42RLE TRANSMISSION VERIFICATION TEST - VER 1.</p> | All |

P0846-2/4 PRESSURE SWITCH SENSE CIRCUIT — Continued

| TEST | ACTION | APPLICABILITY |
|------|---|---------------|
| 11 | <p>The conditions necessary to set this DTC are not present at this time. Using the schematics as a guide, inspect the wiring and connectors specific to this circuit. Wiggle the wiring while checking for shorts and open circuits. With the DRBIII®, check the EATX EVENT DATA to help identify the conditions in which the DTC was set. Were there any problems found?</p> <p>Yes → Repair as necessary. Perform 42RLE TRANSMISSION VERIFICATION TEST - VER 1.</p> <p>No → Test Complete.</p> | All |

Symptom:

P0870-OD HYDRAULIC PRESSURE TEST FAILURE

When Monitored and Set Condition:

P0870-OD HYDRAULIC PRESSURE TEST FAILURE

When Monitored: In any forward gear with engine speed above 1000 RPM shortly after a shift and every minute thereafter.

Set Condition: After a shift into a forward gear, with engine speed > 1000 RPM, the TCM momentarily turns on element pressure to the clutch ckts that don't have pressure to identify the correct pressure sw closes. If the pressure sw does not close 2 times the code sets

POSSIBLE CAUSES

LOSS OF PRIME DTC P0944 PRESENT
RELATED DTC'S PRESENT
INTERMITTENT WIRING AND CONNECTORS
TRANSMISSION CONTROL RELAY OUTPUT CIRCUIT OPEN
OD PRESSURE SWITCH SENSE CIRCUIT OPEN
OD PRESSURE SWITCH SENSE CIRCUIT SHORT TO GROUND
OD PRESSURE SWITCH SENSE CIRCUIT SHORT TO VOLTAGE
INTERNAL TRANSMISSION
TRANSMISSION CONTROL MODULE

P0870-OD HYDRAULIC PRESSURE TEST FAILURE — Continued

| TEST | ACTION | APPLICABILITY |
|------|--|---------------|
| 1 | <p>NOTE: Low fluid level can be the cause of many Transmission problems. If the fluid level is low, locate and repair the leak, then check and adjust the fluid level per the Service Information.</p> <p>NOTE: Always perform diagnostics with a fully charged battery to avoid false symptoms.</p> <p>With the DRBIII®, read the engine DTC's. Check and repair all engine DTC's prior to performing Transmission Symptom Diagnostics.</p> <p>With the DRBIII®, read Transmission DTC's. Record all DTC's and 1 Trip Failures.</p> <p>NOTE: Diagnose 1 Trip Failures as a fully matured DTC.</p> <p>Using the wiring diagram/schematic as a guide, inspect the wiring and connectors. Repair as necessary.</p> <p>Perform the Shift Lever Position Test. If the test does not pass, refer to Symptom test for P0706 Check Shifter Signal.</p> <p>For Gear Ratio DTC's, check and record all CVI's.</p> <p>Most DTC's set on start up but some must be set by driving the vehicle such that all diagnostic monitors have run.</p> <p>NOTE: Verify flash level of Transmission Control Module. Some problems are corrected by software upgrades to the Transmission Control Module.</p> <p>NOTE: Check for applicable TSB's related to the symptom.</p> <p>Perform this procedure prior to Symptom diagnosis.</p> <p style="text-align: center;">Continue Go To 2</p> | All |
| 2 | <p>With the DRBIII®, check for other Transmission DTCs.</p> <p>Is the DTC P0944 present also?</p> <p style="padding-left: 40px;">Yes → Refer to the Transmission category and perform the appropriate symptom. Perform 42RLE TRANSMISSION VERIFICATION TEST - VER 1.</p> <p style="padding-left: 40px;">No → Go To 3</p> | All |
| 3 | <p>With the DRBIII®, read Transmission DTC's.</p> <p>Is the DTC P0733 and/or P0871 present also?</p> <p style="padding-left: 40px;">Yes → Replace the Transmission or Solenoid/Pressure Switch Assembly per the Service Information. Perform 42RLE TRANSMISSION VERIFICATION TEST - VER 1.</p> <p style="padding-left: 40px;">No → Go To 4</p> | All |
| 4 | <p>With the DRBIII®, Check the STARTS SINCE SET counter for P0870.</p> <p>NOTE: This counter only applies to the last DTC set.</p> <p>Is the STARTS SINCE SET counter 2 or less?</p> <p style="padding-left: 40px;">Yes → Go To 5</p> <p style="padding-left: 40px;">No → Go To 12</p> | All |

P0870-OD HYDRAULIC PRESSURE TEST FAILURE — Continued

| TEST | ACTION | APPLICABILITY |
|------|---|---------------|
| 5 | <p>Turn the ignition off to the lock position. CAUTION: Remove the Starter Relay. This will prevent the vehicle from being started in gear. Install the Transmission Simulator, Miller tool #8333 and the Electronic Transmission Adapter kit 8333-1. NOTE: Check connectors - Clean/repair as necessary. With the Transmission Simulator, select "OD" on the Pressure Switch rotary switch. With the DRBIII®, monitor the OD Pressure Switch state while pressing the Pressure Switch Test button on the Transmission Simulator. Wiggle the wires leading to the TCM while pressing the test button. Did the O/D Pressure Switch state change to closed and remain closed while wiggling the wires?</p> <p style="padding-left: 40px;">Yes → Go To 6</p> <p style="padding-left: 40px;">No → Go To 7</p> | All |
| 6 | <p>If there are no possible causes remaining, view repair.</p> <p style="padding-left: 40px;">Repair</p> <p style="padding-left: 80px;">Disassemble and inspect the Valve Body per the Service Information and repair or replace as necessary. If no problems are found in the Valve Body, replace the Transmission Solenoid/Pressure Switch Assembly per the Service Information. Perform 42RLE TRANSMISSION VERIFICATION TEST - VER 1.</p> | All |
| 7 | <p>Turn the ignition off to the lock position. Disconnect the TCM harness connector. Disconnect the Transmission Solenoid/Pressure Switch Assembly harness connector. Note: Check connectors - Clean/repair as necessary. Measure the resistance of the OD Pressure Switch Sense circuit from the TCM harness connector to the Transmission Solenoid/Pressure Switch Assembly harness connector. Is the resistance above 5.0 ohms?</p> <p style="padding-left: 40px;">Yes → Repair the O/D Pressure Switch Sense circuit for an open. Perform 42RLE TRANSMISSION VERIFICATION TEST - VER 1.</p> <p style="padding-left: 40px;">No → Go To 8</p> | All |
| 8 | <p>Turn the ignition off to the lock position. Disconnect the TCM harness connector. Disconnect the Transmission Solenoid/Pressure Switch Assembly harness connector. Note: Check connectors - Clean/repair as necessary. Measure the resistance between ground and the OD Pressure Switch Sense circuit. Is the resistance below 5.0 ohms?</p> <p style="padding-left: 40px;">Yes → Repair the OD Pressure Switch Sense circuit for a short to ground. Perform 42RLE TRANSMISSION VERIFICATION TEST - VER 1.</p> <p style="padding-left: 40px;">No → Go To 9</p> | All |

P0870-OD HYDRAULIC PRESSURE TEST FAILURE — Continued

| TEST | ACTION | APPLICABILITY |
|------|--|---------------|
| 9 | <p>Turn the ignition off to the lock position. Disconnect the TCM harness connector. Disconnect the Transmission Solenoid/Pressure Switch Assembly harness connector. Remove the Transmission Control Relay. Note: Check connectors - Clean/repair as necessary. Connect a jumper wire between the Fused B+ circuit and the Transmission Control Relay Output circuit in the Transmission Control Relay connector. Ignition on, engine not running. Measure the voltage of the OD Pressure Switch Sense circuit. Is the voltage above 0.5 volt?</p> <p>Yes → Repair OD Pressure Switch Sense circuit for a short to voltage. Perform 42RLE TRANSMISSION VERIFICATION TEST - VER 1.</p> <p>No → Go To 10</p> | All |
| 10 | <p>Turn the ignition off to the lock position. Disconnect the Transmission Solenoid/Pressure Switch Assembly harness connector. Remove the Transmission Control Relay. Note: Check connectors - Clean/repair as necessary. Connect a jumper wire between the Fused B+ circuit and the Transmission Control Relay Output circuit in the Transmission Control Relay connector. Ignition on, engine not running. Using a 12-volt test light connected to ground, check the Transmission Control Relay Output circuit. NOTE: The test light must illuminate brightly. Compare the brightness to that of a direct connection to the battery. Does the test light illuminate brightly?</p> <p>Yes → Go To 11</p> <p>No → Repair the Transmission Control Relay Output circuit for an open or high resistance. If the fuse is open make sure to check for a short to ground. Perform 42RLE TRANSMISSION VERIFICATION TEST - VER 1.</p> | All |
| 11 | <p>Using the schematics as a guide, inspect the wiring and connectors. Repair as necessary. Pay particular attention to all power and ground circuits. If there are no possible causes remaining, view repair.</p> <p>Repair</p> <p>Replace the Transmission Control Module per the Service Information. WITH THE DRBIII® PERFORM QUICK LEARN. Perform 42RLE TRANSMISSION VERIFICATION TEST - VER 1.</p> | All |
| 12 | <p>The conditions necessary to set this DTC are not present at this time. Using the schematics as a guide, inspect the wiring and connectors specific to this circuit. Wiggle the wiring while checking for shorts and open circuits. With the DRBIII®, check the EATX EVENT DATA to help identify the conditions in which the DTC was set. Were there any problems found?</p> <p>Yes → Repair as necessary. Perform 42RLE TRANSMISSION VERIFICATION TEST - VER 1.</p> <p>No → Test Complete.</p> | All |

Symptom:

P0871-OD PRESSURE SWITCH SENSE CIRCUIT

When Monitored and Set Condition:

P0871-OD PRESSURE SWITCH SENSE CIRCUIT

When Monitored: Whenever the engine is running.

Set Condition: The appropriate DTC is set if one of the Pressure Switches are open or closed at the wrong time in a given gear.

POSSIBLE CAUSES

TRANSMISSION CONTROL RELAY DTCS PRESENT
 TRANSMISSION CONTROL RELAY OUTPUT CIRCUIT OPEN
 O/D PRESSURE SWITCH SENSE CIRCUIT OPEN
 O/D PRESSURE SWITCH SENSE CIRCUIT SHORT TO GROUND
 O/D PRESSURE SWITCH SENSE CIRCUIT SHORT TO VOLTAGE
 O/D PRESSURE SWITCH
 TRANSMISSION CONTROL MODULE
 INTERMITTENT WIRING AND CONNECTORS

| TEST | ACTION | APPLICABILITY |
|------|--|---------------|
| 1 | <p>NOTE: Low fluid level can be the cause of many Transmission problems. If the fluid level is low, locate and repair the leak, then check and adjust the fluid level per the Service Information.</p> <p>NOTE: Always perform diagnostics with a fully charged battery to avoid false symptoms.</p> <p>With the DRBIII®, read the engine DTC's. Check and repair all engine DTC's prior to performing Transmission Symptom Diagnostics.</p> <p>With the DRBIII®, read Transmission DTC's. Record all DTC's and 1 Trip Failures.</p> <p>NOTE: Diagnose 1 Trip Failures as a fully matured DTC.</p> <p>Using the wiring diagram/schematic as a guide, inspect the wiring and connectors. Repair as necessary.</p> <p>Perform the Shift Lever Position Test. If the test does not pass, refer to Symptom test for P0706 Check Shifter Signal.</p> <p>For Gear Ratio DTC's, check and record all CVI's.</p> <p>Most DTC's set on start up but some must be set by driving the vehicle such that all diagnostic monitors have run.</p> <p>NOTE: Verify flash level of Transmission Control Module. Some problems are corrected by software upgrades to the Transmission Control Module.</p> <p>NOTE: Check for applicable TSB's related to the symptom.</p> <p>Perform this procedure prior to Symptom diagnosis.</p> <p style="text-align: center;">Continue Go To 2</p> | All |

P0871-OD PRESSURE SWITCH SENSE CIRCUIT — Continued

| TEST | ACTION | APPLICABILITY |
|------|--|---------------|
| 2 | <p>With the DRBIII®, read Transmission DTC's Are there any Transmission Control Relay DTC's present also?</p> <p>Yes → Refer to the Transmission category and perform the appropriate symptom. Perform 42RLE TRANSMISSION VERIFICATION TEST - VER 1.</p> <p>No → Go To 3</p> | All |
| 3 | <p>With the DRBIII®, Check the STARTS SINCE SET counter. NOTE: This counter only applies to the last DTC set. Is the STARTS SINCE SET counter 2 or less for P0871?</p> <p>Yes → Go To 4</p> <p>No → Go To 11</p> | All |
| 4 | <p>Turn the ignition off to the lock position. CAUTION: Remove the Starter Relay. This will prevent the vehicle from being started in gear. Install the Transmission Simulator, Miller tool #8333 and the Electronic Transmission Adapter kit 8333-1. Note: Check connectors - Clean/repair as necessary. Ignition on, engine not running. On the Transmission Simulator, select OD on the Pressure Switch selector switch. With the DRBIII®, monitor the OD Pressure Switch state while pressing the Pressure Switch Test button on the Transmission Simulator. Did the Pressure Switch state change from OPEN to CLOSED when the test button was pressed?</p> <p>Yes → Go To 5</p> <p>No → Go To 6</p> | All |
| 5 | <p>If there are no possible causes remaining, view repair.</p> <p>Repair Replace Transmission Solenoid/Pressure Switch Assembly per the Service Information. Perform 42RLE TRANSMISSION VERIFICATION TEST - VER 1.</p> | All |
| 6 | <p>Turn the ignition off to the lock position. Disconnect the TCM harness connector. Disconnect the Transmission Solenoid/Pressure Switch Assembly harness connector. Note: Check connectors - Clean/repair as necessary. Measure the resistance of the O/D Pressure Switch Sense circuit from the TCM harness connector to the Transmission Solenoid/Pressure Switch Assembly harness connector. Is the resistance above 5.0 ohms?</p> <p>Yes → Repair the O/D Pressure Switch Sense circuit for an open. Perform 42RLE TRANSMISSION VERIFICATION TEST - VER 1.</p> <p>No → Go To 7</p> | All |

P0871-OD PRESSURE SWITCH SENSE CIRCUIT — Continued

| TEST | ACTION | APPLICABILITY |
|------|--|---------------|
| 7 | <p>Turn the ignition off to the lock position. Disconnect the TCM harness connector. Disconnect the Transmission Solenoid/Pressure Switch Assembly harness connector. Note: Check connectors - Clean/repair as necessary. Measure the resistance between ground and the O/D Pressure Switch Sense circuit. Is the resistance below 5.0 ohms?</p> <p style="padding-left: 40px;">Yes → Repair the O/D Pressure Switch circuit for a short to ground. Perform 42RLE TRANSMISSION VERIFICATION TEST - VER 1.</p> <p style="padding-left: 40px;">No → Go To 8</p> | All |
| 8 | <p>Turn the ignition off to the lock position. Disconnect the TCM harness connector. Disconnect the Transmission Solenoid/Pressure Switch Assembly harness connector. Remove the Transmission Control Relay. Note: Check connectors - Clean/repair as necessary. Connect a jumper wire between the Fused B+ circuit and the Transmission Control Relay Output circuit in the Transmission Control Relay connector. Ignition on, engine not running. Measure the voltage of the O/D Pressure Switch Sense circuit. Is the voltage above 0.5 volt?</p> <p style="padding-left: 40px;">Yes → Repair the O/D Pressure Switch Sense circuit for a short to voltage. Perform 42RLE TRANSMISSION VERIFICATION TEST - VER 1.</p> <p style="padding-left: 40px;">No → Go To 9</p> | All |
| 9 | <p>Turn the ignition off to the lock position. Disconnect the Transmission Solenoid/Pressure Switch Assembly harness connector. Remove the Transmission Control Relay. Note: Check connectors - Clean/repair as necessary. Connect a jumper wire between the Fused B+ circuit and the Transmission Control Relay Output circuit in the Transmission Control Relay connector. Ignition on, engine not running. Using a 12-volt test light connected to ground, check the Transmission Control Relay Output circuit. NOTE: The test light must illuminate brightly. Compare the brightness to that of a direct connection to the battery. Does the test light illuminate brightly?</p> <p style="padding-left: 40px;">Yes → Go To 10</p> <p style="padding-left: 40px;">No → Repair the Transmission Control Relay Output circuit for an open or high resistance. If the fuse is open make sure to check for a short to ground. Perform 42RLE TRANSMISSION VERIFICATION TEST - VER 1.</p> | All |
| 10 | <p>Using the schematics as a guide, inspect the wiring and connectors. Repair as necessary. Pay particular attention to all power and ground circuits. If there are no possible causes remaining, view repair.</p> <p style="padding-left: 40px;">Repair</p> <p style="padding-left: 80px;">Replace the Transmission Control Module per the Service Information. WITH THE DRBIII® PERFORM QUICK LEARN. Perform 42RLE TRANSMISSION VERIFICATION TEST - VER 1.</p> | All |

P0871-OD PRESSURE SWITCH SENSE CIRCUIT — Continued

| TEST | ACTION | APPLICABILITY |
|------|--|---------------|
| 11 | <p>The conditions necessary to set this DTC are not present at this time. Using the schematics as a guide, inspect the wiring and connectors specific to this circuit. Wiggle the wiring while checking for shorts and open circuits. With the DRBIII®, check the EATX EVENT DATA to help identify the conditions in which the DTC was set. Were there any problems found?</p> <p style="padding-left: 40px;">Yes → Repair as necessary. Perform 42RLE TRANSMISSION VERIFICATION TEST - VER 1.</p> <p style="padding-left: 40px;">No → Test Complete.</p> | All |

Symptom:
P0884-POWER UP AT SPEED

When Monitored and Set Condition:

P0884-POWER UP AT SPEED

When Monitored: When Transmission Control Module powers up.

Set Condition: This DTC will set if the TCM powers up and senses the vehicle in a valid forward gear (no PRNDL DTCs) with a output speed above 800 RPM (approximately 32Km/h or 20 MPH).

POSSIBLE CAUSES

POWER UP AT SPEED

| TEST | ACTION | APPLICABILITY |
|------|--|---------------|
| 1 | <p>This DTC is set when the TCM is initialized while the vehicle is moving down the road in a valid forward gear. Check all of the Fused B+, Fused Ignition Switch Output, and Ground circuits to the TCM for an intermittent open or short to ground. Were there any problems found?</p> <p>Yes → Repair wiring and/or connectors as necessary. Perform 42RLE TRANSMISSION VERIFICATION TEST - VER 1.</p> <p>No → Go To 2</p> | All |
| 2 | <p>NOTE: Low fluid level can be the cause of many Transmission problems. If the fluid level is low, locate and repair the leak, then check and adjust the fluid level per the Service Information. NOTE: Always perform diagnostics with a fully charged battery to avoid false symptoms. With the DRBIII®, read the engine DTC's. Check and repair all engine DTC's prior to performing Transmission Symptom Diagnostics. With the DRBIII®, read Transmission DTC's. Record all DTC's and 1 Trip Failures. NOTE: Diagnose 1 Trip Failures as a fully matured DTC. Using the wiring diagram/schematic as a guide, inspect the wiring and connectors. Repair as necessary. Perform the Shift Lever Position Test. If the test does not pass, refer to Symptom test for P0706 Check Shifter Signal. For Gear Ratio DTC's, check and record all CVI's. Most DTC's set on start up but some must be set by driving the vehicle such that all diagnostic monitors have run. NOTE: Verify flash level of Transmission Control Module. Some problems are corrected by software upgrades to the Transmission Control Module. NOTE: Check for applicable TSB's related to the symptom. Perform this procedure prior to Symptom diagnosis.</p> <p>Continue Test Complete.</p> | All |

Symptom:
P0888-RELAY OUTPUT ALWAYS OFF

When Monitored and Set Condition:

P0888-RELAY OUTPUT ALWAYS OFF

When Monitored: Continuously

Set Condition: This code is set when less than 3 volts are present at the transmission control relay output circuits at the Transmission Control Module when the TCM is energizing the relay.

POSSIBLE CAUSES

- FUSED B+ CIRCUIT OPEN
- TRANSMISSION CONTROL RELAY GROUND CIRCUIT OPEN
- INTERMITTENT WIRING AND CONNECTORS

| TEST | ACTION | APPLICABILITY |
|------|--|---------------|
| 1 | <p>NOTE: Low fluid level can be the cause of many Transmission problems. If the fluid level is low, locate and repair the leak, then check and adjust the fluid level per the Service Information.</p> <p>NOTE: Always perform diagnostics with a fully charged battery to avoid false symptoms.</p> <p>With the DRBIII®, read the engine DTC's. Check and repair all engine DTC's prior to performing Transmission Symptom Diagnostics.</p> <p>With the DRBIII®, read Transmission DTC's. Record all DTC's and 1 Trip Failures.</p> <p>NOTE: Diagnose 1 Trip Failures as a fully matured DTC.</p> <p>Using the wiring diagram/schematic as a guide, inspect the wiring and connectors. Repair as necessary.</p> <p>Perform the Shift Lever Position Test. If the test does not pass, refer to Symptom test for P0706 Check Shifter Signal.</p> <p>For Gear Ratio DTC's, check and record all CVI's.</p> <p>Most DTC's set on start up but some must be set by driving the vehicle such that all diagnostic monitors have run.</p> <p>NOTE: Verify flash level of Transmission Control Module. Some problems are corrected by software upgrades to the Transmission Control Module.</p> <p>NOTE: Check for applicable TSB's related to the symptom.</p> <p>Perform this procedure prior to Symptom diagnosis.</p> <p style="text-align: center;">Continue Go To 2</p> | All |
| 2 | <p>With the DRBIII®, Check the STARTS SINCE SET counter for P0888.</p> <p>Note: This counter only applies to the last DTC set.</p> <p>Is the STARTS SINCE SET counter set at 0?</p> <p style="text-align: center;">Yes → Go To 3 No → Go To 5</p> | All |

P0888-RELAY OUTPUT ALWAYS OFF — Continued

| TEST | ACTION | APPLICABILITY |
|------|--|---------------|
| 3 | <p>Turn the ignition off to the lock position. Remove the Transmission Control Relay. Note: Check connectors - Clean/repair as necessary. Ignition on, engine not running. Using a 12-volt test light connected to ground, check the Fused B+ circuit in the Transmission Control Relay connector. NOTE: The test light must illuminate brightly. Compare the brightness to that of a direct connection to the battery. Does the test light illuminate brightly?</p> <p>Yes → Go To 4</p> <p>No → Repair the Fused B+ circuit for an open or high resistance. If the fuse is open make sure to check for a short to ground. Perform 42RLE TRANSMISSION VERIFICATION TEST - VER 1.</p> | All |
| 4 | <p>Turn the ignition off to the lock position. Remove the Transmission Control Relay. Note: Check connectors - Clean/repair as necessary. Using a 12-volt test light connected to 12-volts, check the Transmission Control Relay Ground circuit. NOTE: The test light must illuminate brightly. Compare the brightness to that of a direct connection to the battery. Does the test light illuminate brightly?</p> <p>Yes → Test Complete.</p> <p>No → Repair the Transmission Control Relay Ground circuit for an open or high resistance. Perform 42RLE TRANSMISSION VERIFICATION TEST - VER 1.</p> | All |
| 5 | <p>The conditions necessary to set this DTC are not present at this time. Using the schematics as a guide, inspect the wiring and connectors specific to this circuit. Wiggle the wiring while checking for shorts and open circuits. With the DRBIII®, check the EATX EVENT DATA to help identify the conditions in which the DTC was set. Were there any problems found?</p> <p>Yes → Repair as necessary. Perform 42RLE TRANSMISSION VERIFICATION TEST - VER 1.</p> <p>No → Test Complete.</p> | All |

Symptom:
P0890-SWITCHED BATTERY

When Monitored and Set Condition:

P0890-SWITCHED BATTERY

When Monitored: Ignition key is turned from the OFF position to RUN position and/or ignition key is turned from the CRANK position to RUN position.

Set Condition: This DTC is set if the Transmission Control Module senses voltage on any of the Pressure Switch Inputs prior to the TCM energizing the Transmission Control Relay.

POSSIBLE CAUSES

2/4 PRESSURE SWITCH SENSE CIRCUIT SHORT TO VOLTAGE
 L/R PRESSURE SWITCH SENSE CIRCUIT SHORT TO VOLTAGE
 INTERMITTENT WIRING AND CONNECTORS

| TEST | ACTION | APPLICABILITY |
|------|---|---------------|
| 1 | <p>NOTE: Low fluid level can be the cause of many Transmission problems. If the fluid level is low, locate and repair the leak, then check and adjust the fluid level per the Service Information.</p> <p>NOTE: Always perform diagnostics with a fully charged battery to avoid false symptoms.</p> <p>With the DRBIII®, read the engine DTC's. Check and repair all engine DTC's prior to performing Transmission Symptom Diagnostics.</p> <p>With the DRBIII®, read Transmission DTC's. Record all DTC's and 1 Trip Failures.</p> <p>NOTE: Diagnose 1 Trip Failures as a fully matured DTC.</p> <p>Using the wiring diagram/schematic as a guide, inspect the wiring and connectors. Repair as necessary.</p> <p>Perform the Shift Lever Position Test. If the test does not pass, refer to Symptom test for P0706 Check Shifter Signal.</p> <p>For Gear Ratio DTC's, check and record all CVI's.</p> <p>Most DTC's set on start up but some must be set by driving the vehicle such that all diagnostic monitors have run.</p> <p>NOTE: Verify flash level of Transmission Control Module. Some problems are corrected by software upgrades to the Transmission Control Module.</p> <p>NOTE: Check for applicable TSB's related to the symptom.</p> <p>Perform this procedure prior to Symptom diagnosis.</p> <p>Continue Go To 2</p> | All |
| 2 | <p>With the DRBIII®, Check the STARTS SINCE SET counter for P0890.</p> <p>Note: This counter only applies to the last DTC set.</p> <p>Is the STARTS SINCE SET counter for P0890 set at 0?</p> <p>Yes → Go To 3</p> <p>No → Go To 5</p> | All |

P0890-SWITCHED BATTERY — Continued

| TEST | ACTION | APPLICABILITY |
|------|--|---------------|
| 3 | <p>Turn the ignition off to the lock position. Disconnect the TCM harness connector. Disconnect the Transmission Solenoid/Pressure Switch Assembly harness connector. Remove the Transmission Control Relay. Note: Check connectors - Clean/repair as necessary. Connect a jumper wire between the Fused B+ circuit and the Transmission Control Relay Output circuit in the Transmission Control Relay connector. Ignition on, engine not running. Measure the voltage of the 2/4 Pressure Switch Sense circuit. Is the voltage above 0.5 volt?</p> <p>Yes → Repair the 2/4 Pressure Switch Sense circuit for a short to voltage. Perform 42RLE TRANSMISSION VERIFICATION TEST - VER 1.</p> <p>No → Go To 4</p> | All |
| 4 | <p>Turn the ignition off to the lock position. Disconnect the TCM harness connector. Disconnect the Transmission Solenoid/Pressure Switch Assembly harness connector. Remove the Transmission Control Relay from the PDC. Note: Check connectors - Clean/repair as necessary. Connect a jumper wire between the Fused B+ circuit and the Transmission Control Relay Output circuit in the Transmission Control Relay connector. Ignition on, engine not running. Measure the voltage of the L/R Pressure Switch Sense circuit. Is the voltage above 0.5 volt?</p> <p>Yes → Repair the L/R Pressure Switch Sense circuit for a short to voltage. Perform 42RLE TRANSMISSION VERIFICATION TEST - VER 1.</p> <p>No → Test Complete.</p> | All |
| 5 | <p>The conditions necessary to set this DTC are not present at this time. Using the schematics as a guide, inspect the wiring and connectors specific to this circuit. Wiggle the wiring while checking for shorts and open circuits. With the DRBIII®, check the EATX EVENT DATA to help identify the conditions in which the DTC was set. Were there any problems found?</p> <p>Yes → Repair as necessary. Perform 42RLE TRANSMISSION VERIFICATION TEST - VER 1.</p> <p>No → Test Complete.</p> | All |

Symptom:

P0891-TRANSMISSION RELAY ALWAYS ON

When Monitored and Set Condition:

P0891-TRANSMISSION RELAY ALWAYS ON

When Monitored: When the ignition is turned from the OFF position to the RUN position and/or the ignition is turned from the CRANK position to RUN position.

Set Condition: This DTC is set if the Transmission Control Module senses greater than 3.0 volts at the Transmission Control Relay Output terminal of the TCM prior to the TCM energizing the Transmission Control Relay.

POSSIBLE CAUSES

- INTERMITTENT WIRING AND CONNECTORS
- TRANSMISSION CONTROL RELAY STUCK CLOSED
- TRANSMISSION CONTROL RELAY OUTPUT CIRCUIT SHORT TO VOLTAGE
- TRANSMISSION RELAY CONTROL CIRCUIT SHORT TO VOLTAGE
- TRANSMISSION CONTROL MODULE

| TEST | ACTION | APPLICABILITY |
|----------|--|---------------|
| <p>1</p> | <p>NOTE: Low fluid level can be the cause of many Transmission problems. If the fluid level is low, locate and repair the leak, then check and adjust the fluid level per the Service Information.</p> <p>NOTE: Always perform diagnostics with a fully charged battery to avoid false symptoms.</p> <p>With the DRBIII®, read the engine DTC's. Check and repair all engine DTC's prior to performing Transmission Symptom Diagnostics.</p> <p>With the DRBIII®, read Transmission DTC's. Record all DTC's and 1 Trip Failures.</p> <p>NOTE: Diagnose 1 Trip Failures as a fully matured DTC.</p> <p>Using the wiring diagram/schematic as a guide, inspect the wiring and connectors. Repair as necessary.</p> <p>Perform the Shift Lever Position Test. If the test does not pass, refer to Symptom test for P0706 Check Shifter Signal.</p> <p>For Gear Ratio DTC's, check and record all CVI's.</p> <p>Most DTC's set on start up but some must be set by driving the vehicle such that all diagnostic monitors have run.</p> <p>NOTE: Verify flash level of Transmission Control Module. Some problems are corrected by software upgrades to the Transmission Control Module.</p> <p>NOTE: Check for applicable TSB's related to the symptom.</p> <p>Perform this procedure prior to Symptom diagnosis.</p> <p>Continue Go To 2</p> | <p>All</p> |

P0891-TRANSMISSION RELAY ALWAYS ON — Continued

| TEST | ACTION | APPLICABILITY |
|------|---|---------------|
| 2 | <p>With the DRBIII®, check the STARTS SINCE SET counter for P0891. Note: This counter only applies to the last DTC set. Is the STARTS SINCE SET counter set to 0?</p> <p>Yes → Go To 3</p> <p>No → Go To 7</p> | All |
| 3 | <p>Turn the ignition off to the lock position. Remove the Transmission Control Relay from the PDC. Note: Check connectors - Clean/repair as necessary. Measure the resistance between the Fused B+ circuit and the Transmission Control Relay Output Circuit in the Transmission Control Relay. Is the resistance above 5.0 ohms?</p> <p>Yes → Go To 4</p> <p>No → Replace the Transmission Control Relay. Perform 42RLE TRANSMISSION VERIFICATION TEST - VER 1.</p> | All |
| 4 | <p>Turn the ignition off to the lock position. Disconnect the TCM harness connector. Disconnect the Solenoid/Pressure Switch Assembly harness connector. Remove the Transmission Control Relay from the PDC. Note: Check connectors - Clean/repair as necessary. Ignition on, engine not running. Measure the voltage of the Transmission Control Relay Output circuit in the Solenoid/Pressure Switch Assembly harness connector. Is the voltage above 0.5 volt?</p> <p>Yes → Repair the Transmission Control Relay Output circuit for a short to voltage Perform 42RLE TRANSMISSION VERIFICATION TEST - VER 1.</p> <p>No → Go To 5</p> | All |
| 5 | <p>Turn the ignition off to the lock position. Remove the Transmission Control Relay from the PDC. Ignition on, engine not running. Note: Check connectors - Clean/repair as necessary. Measure the voltage of the Transmission Relay Control circuit in the PDC connector. Is the voltage above 0.5 volt?</p> <p>Yes → Repair Transmission Relay Control Circuit for a short to voltage. Perform 42RLE TRANSMISSION VERIFICATION TEST - VER 1.</p> <p>No → Go To 6</p> | All |
| 6 | <p>Using the schematics as a guide, inspect the wiring and connectors. Repair as necessary. Pay particular attention to all power and ground circuits. If there are no possible causes remaining, view repair.</p> <p>Repair</p> <p>Replace the Transmission Control Module per the Service Information. WITH THE DRBIII® PERFORM QUICK LEARN. Perform 42RLE TRANSMISSION VERIFICATION TEST - VER 1.</p> | All |

P0891-TRANSMISSION RELAY ALWAYS ON — Continued

| TEST | ACTION | APPLICABILITY |
|-------------|---|----------------------|
| 7 | <p>The conditions necessary to set this DTC are not present at this time. Using the schematics as a guide, inspect the wiring and connectors specific to this circuit. Wiggle the wiring while checking for shorts and open circuits. With the DRBIII®, check the EATX EVENT DATA to help identify the conditions in which the DTC was set. Were there any problems found?</p> <p>Yes → Repair as necessary. Perform 42RLE TRANSMISSION VERIFICATION TEST - VER 1.</p> <p>No → Test Complete.</p> | All |

Symptom:

P0897-WORN OUT/BURNT TRANSAXLE FLUID

When Monitored and Set Condition:

P0897-WORN OUT/BURNT TRANSAXLE FLUID

When Monitored: With each transition from full Torque Converter to partial Torque Converter engagement for A/C bump prevention.

Set Condition: When vehicle shudder is detected during partial engagement (PEMCC).

POSSIBLE CAUSES

WORN OUT/ BURNT TRANSMISSION FLUID

| TEST | ACTION | APPLICABILITY |
|------|--|---------------|
| 1 | <p>NOTE: Low fluid level can be the cause of many Transmission problems. If the fluid level is low, locate and repair the leak, then check and adjust the fluid level per the Service Information.</p> <p>NOTE: Always perform diagnostics with a fully charged battery to avoid false symptoms.</p> <p>With the DRBIII®, read the engine DTC's. Check and repair all engine DTC's prior to performing Transmission Symptom Diagnostics.</p> <p>With the DRBIII®, read Transmission DTC's. Record all DTC's and 1 Trip Failures.</p> <p>NOTE: Diagnose 1 Trip Failures as a fully matured DTC.</p> <p>Using the wiring diagram/schematic as a guide, inspect the wiring and connectors. Repair as necessary.</p> <p>Perform the Shift Lever Position Test. If the test does not pass, refer to Symptom test for P0706 Check Shifter Signal.</p> <p>For Gear Ratio DTC's, check and record all CVI's.</p> <p>Most DTC's set on start up but some must be set by driving the vehicle such that all diagnostic monitors have run.</p> <p>NOTE: Verify flash level of Transmission Control Module. Some problems are corrected by software upgrades to the Transmission Control Module.</p> <p>NOTE: Check for applicable TSB's related to the symptom.</p> <p>Perform this procedure prior to Symptom diagnosis.</p> <p>Continue Go To 2</p> | All |

P0897-WORN OUT/BURNT TRANSAXLE FLUID — Continued

| TEST | ACTION | APPLICABILITY |
|------|--|---------------|
| 2 | <p>Turn the ignition off.</p> <p>Remove the Transmission Oil Pan and Oil Filter per the Service Information.</p> <p>Install a new Transmission Oil Filter per Service Information.</p> <p>Reinstall Transmission Oil Pan, and refill with new Transmission Fluid per the Service Information.</p> <p>Note: The Transmission Cooler must be flushed before proceeding.</p> <p>Start the engine, check and adjust the Transmission Fluid Level per Service Information.</p> <p>Allow the engine to idle for 10 minutes, in Park.</p> <p>Flush the Transmission Oil Cooler per the Service Information.</p> <p>Turn the ignition off.</p> <p>Drain and refill the Transmission Fluid.</p> <p>Flush the Transmission Oil Cooler again.</p> <p>Start the engine, check and adjust the Transmission Fluid Level per Service Information.</p> <p>With the DRBIII®, perform a Battery Disconnect.</p> <p>Note: This must be done to re enable EMCC during an A/C Clutch engagement.</p> <p>The vehicle may exhibit intermittent shudder during the first few hundred miles.</p> <p>Note: The oil will gradually penetrate the TCC friction material and the shudder should disappear.</p> <p>Erase the DTC and return the vehicle to the customer.</p> <p>Did the Code reset or does the vehicle still shudder after a few thousand miles?</p> <p style="padding-left: 40px;">Yes → Replace the Torque Convertor per the Service Information. Note: After replacing the Torque Convertor, use the DRBIII to perform the TCC Break In procedure. This will prevent a possible shudder condition.</p> <p style="padding-left: 40px;">Perform 42RLE TRANSMISSION VERIFICATION TEST - VER 1.</p> <p style="padding-left: 40px;">No → Test Complete.</p> | All |

Symptom:

P0944-LOSS OF PRIME

When Monitored and Set Condition:

P0944-LOSS OF PRIME

When Monitored: If the transmission is slipping in any forward gear and the pressure switches are not indicating pressure, a loss of prime test is run.

Set Condition: If the Trans. begins to slip in a forward gear & the press. switch(s) that should be closed are open a loss of prime test begins. Available elements are turned on by the TCM to see if pump prime exists. The code sets if no pressure switches respond.

POSSIBLE CAUSES

SHIFT LEVER POSITION
 PLUGGED TRANSMISSION OIL FILTER
 TRANSMISSION OIL PUMP
 INTERMITTENT WIRING AND CONNECTORS

| TEST | ACTION | APPLICABILITY |
|------|---|---------------|
| 1 | <p>NOTE: Low fluid level can be the cause of many Transmission problems. If the fluid level is low, locate and repair the leak, then check and adjust the fluid level per the Service Information.</p> <p>NOTE: Always perform diagnostics with a fully charged battery to avoid false symptoms.</p> <p>With the DRBIII®, read the engine DTC's. Check and repair all engine DTC's prior to performing Transmission Symptom Diagnostics.</p> <p>With the DRBIII®, read Transmission DTC's. Record all DTC's and 1 Trip Failures.</p> <p>NOTE: Diagnose 1 Trip Failures as a fully matured DTC.</p> <p>Using the wiring diagram/schematic as a guide, inspect the wiring and connectors. Repair as necessary.</p> <p>Perform the Shift Lever Position Test. If the test does not pass, refer to Symptom test for P0706 Check Shifter Signal.</p> <p>For Gear Ratio DTC's, check and record all CVI's.</p> <p>Most DTC's set on start up but some must be set by driving the vehicle such that all diagnostic monitors have run.</p> <p>NOTE: Verify flash level of Transmission Control Module. Some problems are corrected by software upgrades to the Transmission Control Module.</p> <p>NOTE: Check for applicable TSB's related to the symptom.</p> <p>Perform this procedure prior to Symptom diagnosis.</p> <p>Continue Go To 2</p> | All |

P0944-LOSS OF PRIME — Continued

| TEST | ACTION | APPLICABILITY |
|------|---|---------------|
| 2 | Place the gear selector in park. Start the engine. NOTE: The TRANS TEMP DEG must be at least 43° C or 110° F before performing the following steps. The Transmission must be at operating temperature prior to checking pressure. A cold Transmission will give higher readings. Place the Transmission in Reverse. With the DRBIII®, observe the Transmission Pressure Switch states. Are any of the Pressure Switches closed? Yes → Go To 3 No → Go To 5 | All |
| 3 | The conditions necessary to set this DTC are not present at this time. Test drive the vehicle. Allow the Transmission to shift through all gears and ranges. Did you experience a delayed engagement and/or a no drive condition? Yes → Go To 5 No → Go To 4 | All |
| 4 | The conditions necessary to set this DTC are not present at this time. Using the schematics as a guide, inspect the wiring and connectors specific to this circuit. Wiggle the wiring while checking for shorts and open circuits. With the DRBIII®, check the EATX EVENT DATA to help identify the conditions in which the DTC was set. Were there any problems found? Yes → Repair as necessary. Perform 42RLE TRANSMISSION VERIFICATION TEST - VER 1. No → Test Complete. | All |
| 5 | With the DRBIII®, perform a Shift Lever Position test. Follow the instructions on the DRBIII®. Did the Shift Lever Position Test pass? Yes → Go To 6 No → Refer to symptom list and perform test for DTC P0706. Perform 42RLE TRANSMISSION VERIFICATION TEST - VER 1. | All |
| 6 | Remove and inspect the Transmission Oil Pan and Transmission Oil Filter per the Service Information. Does the Transmission Oil Pan contain excessive debris and/or is the Oil Filter plugged? Yes → Repair the cause of the plugged Transmission Oil Filter. Refer to the Service Information for the proper repair procedure. Perform 42RLE TRANSMISSION VERIFICATION TEST - VER 1. No → Go To 7 | All |

P0944-LOSS OF PRIME — Continued

| TEST | ACTION | APPLICABILITY |
|------|--|---------------|
| 7 | If there are no possible causes remaining, view repair. Repair Replace the Transmission Oil Pump per the Service Information. Perform 42RLE TRANSMISSION VERIFICATION TEST - VER 1. | All |

Symptom:

P0992- 2-4/OD HYDRAULIC PRESSURE TEST FAILURE

When Monitored and Set Condition:

P0992- 2-4/OD HYDRAULIC PRESSURE TEST FAILURE

When Monitored: In any forward gear with engine speed above 1000 RPM shortly after a shift and every minute thereafter.

Set Condition: After a shift into a forward gear, with engine speed > 1000 RPM, the TCM momentarily turns on element pressure to the clutch ckts that don't have pressure to identify the correct pressure sw closes. If the pressure sw does not close 2 times the code sets.

POSSIBLE CAUSES

CONDITION P0992 PRESENT

| TEST | ACTION | APPLICABILITY |
|------|--|---------------|
| 1 | <p>NOTE: Low fluid level can be the cause of many Transmission problems. If the fluid level is low, locate and repair the leak, then check and adjust the fluid level per the Service Information.</p> <p>NOTE: Always perform diagnostics with a fully charged battery to avoid false symptoms.</p> <p>With the DRBIII®, read the engine DTC's. Check and repair all engine DTC's prior to performing Transmission Symptom Diagnostics.</p> <p>With the DRBIII®, read Transmission DTC's. Record all DTC's and 1 Trip Failures.</p> <p>NOTE: Diagnose 1 Trip Failures as a fully matured DTC.</p> <p>Using the wiring diagram/schematic as a guide, inspect the wiring and connectors. Repair as necessary.</p> <p>Perform the Shift Lever Position Test. If the test does not pass, refer to Symptom test for P0706 Check Shifter Signal.</p> <p>For Gear Ratio DTC's, check and record all CVT's.</p> <p>Most DTC's set on start up but some must be set by driving the vehicle such that all diagnostic monitors have run.</p> <p>NOTE: Verify flash level of Transmission Control Module. Some problems are corrected by software upgrades to the Transmission Control Module.</p> <p>NOTE: Check for applicable TSB's related to the symptom.</p> <p>Perform this procedure prior to Symptom diagnosis.</p> <p style="text-align: center;">Continue Go To 2</p> | All |

P0992- 2-4/OD HYDRAULIC PRESSURE TEST FAILURE — Continued

| TEST | ACTION | APPLICABILITY |
|------|--|---------------|
| 2 | <p>NOTE: The vehicle must be driven to set this DTC, the transmission must be warm or hot with the Engine RPM above 1000 RPM. This DTC is an indicator of a 2/4 and/or O/D Hydraulic Pressure Switch DTC's present. Perform the tests for P0870 and/or P0845 to determine which switch is failing. If there are no possible causes remaining, view repair.</p> <p style="padding-left: 40px;">Repair</p> <p style="padding-left: 80px;">Refer to the Transmission category and perform the appropriate symptom for P0870 and/or P0845. Perform 42RLE TRANSMISSION VERIFICATION TEST - VER 1.</p> | All |

Symptom:**P1652-SERIAL COMMUNICATION LINK MALFUNCTION****When Monitored and Set Condition:****P1652-SERIAL COMMUNICATION LINK MALFUNCTION**

When Monitored: Continuously with engine running.

Set Condition: The DTC sets in approximately 20 seconds if no BUS messages are received by the TCM.

POSSIBLE CAUSES

NO COMMUNICATION WITH MIC
 NO COMMUNICATION WITH PCM
 INTERMITTENT WIRING AND CONNECTORS
 TRANSMISSION CONTROL MODULE

| TEST | ACTION | APPLICABILITY |
|------|---|---------------|
| 1 | With the DRBIII®, erase TCM DTC's. Note: Erase P0700 DTC in the PCM to turn the MIL light off after making transmission repairs. Start the engine in park. Did the DTC reset after the engine was started? Yes → Go To 2 No → Go To 5 | All |
| 2 | Ignition on, engine not running. With the DRBIII®, attempt communication with the MIC Can you communicate with the MIC? Yes → Go To 3 No → Refer to the Communication category for the related symptom(s). Perform 42RLE TRANSMISSION VERIFICATION TEST - VER 1. | All |
| 3 | Ignition on, engine not running. With the DRBIII®, select the following screens in order: "BODY" "MIC" "MONITOR DISPLAY" "PCI BUS ENGINE INFO". Does the DRBIII®, read "NO RESPONSE" from any of the listed PCM monitors? Yes → Refer to Communication Category for the related symptom(s). Perform 42RLE TRANSMISSION VERIFICATION TEST - VER 1. No → Go To 4 | All |

P1652-SERIAL COMMUNICATION LINK MALFUNCTION — Continued

| TEST | ACTION | APPLICABILITY |
|------|---|---------------|
| 4 | <p>Using the schematics as a guide, inspect the wiring and connectors. Repair as necessary. Pay particular attention to all power and ground circuits. If there are no possible causes remaining, view repair.</p> <p>Repair</p> <p>Replace the Transmission Control Module per the Service Information. WITH THE DRBIII® PERFORM QUICK LEARN. Perform 42RLE TRANSMISSION VERIFICATION TEST - VER 1.</p> | All |
| 5 | <p>The conditions necessary to set this DTC are not present at this time. Using the schematics as a guide, inspect the wiring and connectors specific to this circuit. Wiggle the wiring while checking for shorts and open circuits. With the DRBIII®, check the EATX EVENT DATA to help identify the conditions in which the DTC was set. Were there any problems found?</p> <p>Yes → Repair as necessary. Perform 42RLE TRANSMISSION VERIFICATION TEST - VER 1.</p> <p>No → Test Complete.</p> | All |

Symptom:
P1684-BATTERY WAS DISCONNECTED

When Monitored and Set Condition:

P1684-BATTERY WAS DISCONNECTED

When Monitored: Whenever the key is in the Run/Start position.

Set Condition: This code is set whenever Transmission Control Module (TCM) is disconnected from battery power B+ or ground. It will also be set during the DRBIII® Quick Battery Disconnect procedure.

POSSIBLE CAUSES

- QUICK LEARN WAS PERFORMED
- RECENT BATTERY DISCONNECTION
- TCM WAS REPLACED OR DISCONNECTED
- INTERMITTENT WIRING AND CONNECTORS
- FUSED B+ CIRCUIT TO TCM OPEN
- GROUND CIRCUIT OPEN

| TEST | ACTION | APPLICABILITY |
|------|--|---------------|
| 1 | <p>NOTE: Low fluid level can be the cause of many Transmission problems. If the fluid level is low, locate and repair the leak, then check and adjust the fluid level per the Service Information.</p> <p>NOTE: Always perform diagnostics with a fully charged battery to avoid false symptoms.</p> <p>With the DRBIII®, read the engine DTC's. Check and repair all engine DTC's prior to performing Transmission Symptom Diagnostics.</p> <p>With the DRBIII®, read Transmission DTC's. Record all DTC's and 1 Trip Failures.</p> <p>NOTE: Diagnose 1 Trip Failures as a fully matured DTC.</p> <p>Using the wiring diagram/schematic as a guide, inspect the wiring and connectors. Repair as necessary.</p> <p>Perform the Shift Lever Position Test. If the test does not pass, refer to Symptom test for P0706 Check Shifter Signal.</p> <p>For Gear Ratio DTC's, check and record all CVI's.</p> <p>Most DTC's set on start up but some must be set by driving the vehicle such that all diagnostic monitors have run.</p> <p>NOTE: Verify flash level of Transmission Control Module. Some problems are corrected by software upgrades to the Transmission Control Module.</p> <p>NOTE: Check for applicable TSB's related to the symptom.</p> <p>Perform this procedure prior to Symptom diagnosis.</p> <p style="text-align: center;">Continue Go To 2</p> | All |

P1684-BATTERY WAS DISCONNECTED — Continued

| TEST | ACTION | APPLICABILITY |
|------|---|---------------|
| 2 | Turn ignition off to the lock position. Disconnect the TCM harness connector. Ignition on, engine not running. Measure the voltage of the Fused B+ circuit in the TCM harness connector. Is the voltage below 10.0 volts? Yes → Go To 3 No → Go To 5 | All |
| 3 | Turn the ignition off to the lock position. Disconnect the TCM harness connector. Note: Check connectors - Clean/repair as necessary. Ignition on, engine not running. Using a 12-volt test light connected to ground, check the Fused B+ circuit in the TCM harness connector. NOTE: The test light must illuminate brightly. Compare the brightness to that of a direct connection to the battery. Does the test light illuminate brightly? Yes → Go To 4 No → Repair the Fused B+ circuit for an open or high resistance. If the fuse is open make sure to check for a short to ground. Perform 42RLE TRANSMISSION VERIFICATION TEST - VER 1. | All |
| 4 | Turn ignition off to the lock position. Disconnect the TCM harness connector. Note: Check connectors - Clean/repair as necessary. Using a 12-volt test light connected to 12-volts, check all the ground circuits in the TCM harness connector. NOTE: The test light must illuminate brightly. Compare the brightness to that of a direct connection to the battery. Does the light illuminate brightly at all the ground circuits? Yes → Test Complete. No → Repair the Ground circuit(s) as necessary. Perform 42RLE TRANSMISSION VERIFICATION TEST - VER 1. | All |
| 5 | Has the battery been disconnected, lost it's charge, or been replaced recently? Yes → This is the cause of the DTC. Erase the DTC and return the vehicle to the customer. Perform 42RLE TRANSMISSION VERIFICATION TEST - VER 1. No → Go To 6 | All |
| 6 | Has the Quick Learn procedure been performed? Yes → This is the cause of the DTC. Erase the DTC and return the vehicle to the customer. Perform 42RLE TRANSMISSION VERIFICATION TEST - VER 1. No → Go To 7 | All |

P1684-BATTERY WAS DISCONNECTED — Continued

| TEST | ACTION | APPLICABILITY |
|------|---|---------------|
| 7 | <p>Has the TCM been replaced or disconnected?</p> <p>Yes → Replacing or disconnecting the TCM will set this DTC. Erase the DTC and return the vehicle to the customer. Perform 42RLE TRANSMISSION VERIFICATION TEST - VER 1.</p> <p>No → Go To 8</p> | All |
| 8 | <p>The conditions necessary to set this DTC are not present at this time. Using the schematics as a guide, inspect the wiring and connectors specific to this circuit. Wiggle the wiring while checking for shorts and open circuits. Were there any problems found?</p> <p>Yes → Repair as necessary. Perform 42RLE TRANSMISSION VERIFICATION TEST - VER 1.</p> <p>No → Test Complete.</p> | All |

Symptom:

P1687-NO COMMUNICATION WITH THE MIC

When Monitored and Set Condition:

P1687-NO COMMUNICATION WITH THE MIC

When Monitored: Continuously with engine running.

Set Condition: The code sets in approximately 25 seconds if no BUS messages are received from the MIC.

POSSIBLE CAUSES

OTHER BUS PROBLEMS PRESENT
 INTERMITTENT WIRING AND CONNECTORS
 MIC - NO COMMUNICATION
 TRANSMISSION CONTROL MODULE

| TEST | ACTION | APPLICABILITY |
|------|---|---------------|
| 1 | With the DRBIII®, Check the STARTS SINCE SET counter for P1687. Note: This counter only applies to the last DTC set. Is the STARTS SINCE SET counter set at 0? Yes → Go To 2 No → Go To 5 | All |
| 2 | With the DRBIII®, check all of the other modules on the vehicle for evidence of a vehicle bus problem. Bus related DTC's in other modules point to an overall vehicle bus problem. Other symptoms such as a customer complaint of intermittent operation of bus controlled features also indicate a bus problem. Does the PRNDL display indicate "No Bus" or is there any evidence of an overall vehicle bus problem? Yes → Refer to the Communications category and perform the appropriate symptom. Perform 42RLE TRANSMISSION VERIFICATION TEST - VER 1. No → Go To 3 | All |
| 3 | Ignition on, engine not running. With the DRBIII®, clear all DTC's. Start the engine in park. With the DRBIII®, read the MIC DTC's. Can the DRBIII® communicate with the MIC? Yes → Go To 4 No → Refer to the Communication category and perform the appropriate symptom related to No Response to MIC. Perform 42RLE TRANSMISSION VERIFICATION TEST - VER 1. | All |

P1687-NO COMMUNICATION WITH THE MIC — Continued

| TEST | ACTION | APPLICABILITY |
|------|---|---------------|
| 4 | Ignition on, engine not running. With the DRBIII®, erase TCM DTC's. Start the engine in park. With the DRBIII®, read Transmission DTC's. Is the DTC, P1687- No Communication with the MIC, present? Yes → Replace the Transmission Control Module per the Service Information. WITH THE DRBIII® PERFORM QUICK LEARN. Perform 42RLE TRANSMISSION VERIFICATION TEST - VER 1. No → Test Complete. | All |
| 5 | The conditions necessary to set this DTC are not present at this time. Using the schematics as a guide, inspect the wiring and connectors specific to this circuit. Wiggle the wiring while checking for shorts and open circuits. With the DRBIII®, check the EATX EVENT DATA to help identify the conditions in which the DTC was set. Were there any problems found? Yes → Repair as necessary. Perform 42RLE TRANSMISSION VERIFICATION TEST - VER 1. No → Test Complete. | All |

Symptom:

P1694-BUS COMMUNICATION WITH ENGINE MODULE

When Monitored and Set Condition:

P1694-BUS COMMUNICATION WITH ENGINE MODULE

When Monitored: Continuously with ignition key on.

Set Condition: If no bus messages are received from the Powertrain Control Module for 10 seconds.

POSSIBLE CAUSES

NO COMMUNICATION WITH PCM
 OTHER BUS PROBLEMS PRESENT
 INTERMITTENT WIRING AND CONNECTORS
 TRANSMISSION CONTROL MODULE

| TEST | ACTION | APPLICABILITY |
|------|--|---------------|
| 1 | With the DRBIII®, Check the STARTS SINCE SET counter for P1694. Note: This counter only applies to the last DTC set. Is the STARTS SINCE SET counter for P1694 set to 0? Yes → Go To 2 No → Go To 5 | All |
| 2 | With the DRBIII®, check all of the other modules on the vehicle for evidence of a vehicle bus problem. Bus related DTC's in other modules point to an overall vehicle bus problem. Other symptoms such as a customer complaint of intermittent operation of bus controlled features also indicate a bus problem. Does the PRNDL display indicate "No Bus" or is there any evidence of an overall vehicle bus problem? Yes → Refer to the Communication category and perform the appropriate symptom. Perform 42RLE TRANSMISSION VERIFICATION TEST - VER 1. No → Go To 3 | All |
| 3 | Ignition on, engine not running. With the DRBIII®, attempt to communicate with the Powertrain Control Module (PCM). Can the DRBIII® communicate with the PCM? Yes → Go To 4 No → Refer to the Communication category and perform the appropriate symptom. Perform 42RLE TRANSMISSION VERIFICATION TEST - VER 1. | All |

P1694-BUS COMMUNICATION WITH ENGINE MODULE — Continued

| TEST | ACTION | APPLICABILITY |
|------|---|---------------|
| 4 | Ignition on, engine not running. With the DRBIII®, erase TCM DTC's. Start the engine in park. With the DRBIII®, read Transmission DTC's. Did the DTC, P1694, return? Yes → Replace the Transmission Control Module per the Service Information. WITH THE DRBIII® PERFORM QUICK LEARN. Perform 42RLE TRANSMISSION VERIFICATION TEST - VER 1. No → Go To 5 | All |
| 5 | The conditions necessary to set this DTC are not present at this time. Using the schematics as a guide, inspect the wiring and connectors specific to this circuit. Wiggle the wiring while checking for shorts and open circuits. With the DRBIII®, check the EATX EVENT DATA to help identify the conditions in which the DTC was set. Were there any problems found? Yes → Repair as necessary. Perform 42RLE TRANSMISSION VERIFICATION TEST - VER 1. No → Test Complete. | All |

Symptom:

P1775-SOLENOID SWITCH VALVE LATCHED IN TCC POSITION

When Monitored and Set Condition:

P1775-SOLENOID SWITCH VALVE LATCHED IN TCC POSITION

When Monitored: During an attempted shift into 1st gear.

Set Condition: This DTC is set if three unsuccessful attempts are made to shift into 1st gear in one given ignition start.

POSSIBLE CAUSES

RELATED DTC P0841 PRESENT

L/R PRESSURE SWITCH

TRANSMISSION CONTROL RELAY OUTPUT CIRCUIT OPEN

L/R PRESSURE SWITCH SENSE CIRCUIT OPEN

L/R PRESSURE SWITCH SENSE CIRCUIT SHORT TO GROUND

L/R PRESSURE SWITCH SENSE CIRCUIT SHORT TO VOLTAGE

TRANSMISSION CONTROL MODULE

INTERMITTENT WIRING AND CONNECTORS

| TEST | ACTION | APPLICABILITY |
|------|--|---------------|
| 1 | <p>NOTE: Low fluid level can be the cause of many Transmission problems. If the fluid level is low, locate and repair the leak, then check and adjust the fluid level per the Service Information.</p> <p>NOTE: Always perform diagnostics with a fully charged battery to avoid false symptoms.</p> <p>With the DRBIII®, read the engine DTC's. Check and repair all engine DTC's prior to performing Transmission Symptom Diagnostics.</p> <p>With the DRBIII®, read Transmission DTC's. Record all DTC's and 1 Trip Failures.</p> <p>NOTE: Diagnose 1 Trip Failures as a fully matured DTC.</p> <p>Using the wiring diagram/schematic as a guide, inspect the wiring and connectors. Repair as necessary.</p> <p>Perform the Shift Lever Position Test. If the test does not pass, refer to Symptom test for P0706 Check Shifter Signal.</p> <p>For Gear Ratio DTC's, check and record all CVI's.</p> <p>Most DTC's set on start up but some must be set by driving the vehicle such that all diagnostic monitors have run.</p> <p>NOTE: Verify flash level of Transmission Control Module. Some problems are corrected by software upgrades to the Transmission Control Module.</p> <p>NOTE: Check for applicable TSB's related to the symptom.</p> <p>Perform this procedure prior to Symptom diagnosis.</p> <p style="text-align: center;">Continue Go To 2</p> | All |

P1775-SOLENOID SWITCH VALVE LATCHED IN TCC POSITION — Continued

| TEST | ACTION | APPLICABILITY |
|------|---|---------------|
| 2 | <p>With the DRBIII®, check for other Transmission DTC's Is the DTC P0841 present also?</p> <p>Yes → Refer to the Transmission category and perform the appropriate symptom. Perform 42RLE TRANSMISSION VERIFICATION TEST - VER 1.</p> <p>No → Go To 3</p> | All |
| 3 | <p>With the DRBIII®, Check the STARTS SINCE SET counter for P1775. NOTE: This counter only applies to the last DTC set. Is the STARTS SINCE SET counter 2 or less?</p> <p>Yes → Go To 4</p> <p>No → Go To 10</p> | All |
| 4 | <p>Turn the ignition off to the lock position. CAUTION: Remove the Starter Relay from the PDC. This will prevent the vehicle from being started in gear. Install the Transmission Simulator, Miller tool #8333 and the FWD Adapter Cable kit, Miller tool #8333-1. Ignition on, engine not running. With the DRBIII®, monitor the L/R Pressure Switch state while pressing the Pressure Switch Test button on the Transmission Simulator. With the Transmission Simulator, select the L/R on the Pressure Switch selector. While observing the LR pressure switch state with the DRBIII®, depress the Pressure Switch Test button. Did the L/R Pressure Switch state change from OPEN to CLOSED when the test button was pressed?</p> <p>Yes → Inspect the Solenoid Switch Valve in the Valve Body per the Service Information and repair or replace as necessary. If no problems are found in Valve Body, replace the Transmission Solenoid/Pressure Switch Assembly per the Service Information. Perform 42RLE TRANSMISSION VERIFICATION TEST - VER 1.</p> <p>No → Go To 5</p> | All |
| 5 | <p>Turn the ignition off to the lock position. Disconnect the TCM harness connector. Disconnect the Transmission Solenoid/Pressure Switch Assembly harness connector. Note: Check connectors - Clean/repair as necessary. Measure the resistance of the L/R Pressure Switch Sense circuit from the TCM harness connector to the Transmission Solenoid/Pressure Switch Assembly harness connector. Is the resistance above 5.0 ohms?</p> <p>Yes → Repair the L/R Pressure Switch Sense circuit for an open. Perform 42RLE TRANSMISSION VERIFICATION TEST - VER 1.</p> <p>No → Go To 6</p> | All |

P1775-SOLENOID SWITCH VALVE LATCHED IN TCC POSITION —
Continued

| TEST | ACTION | APPLICABILITY |
|------|--|---------------|
| 6 | Turn the ignition off to the lock position. Disconnect the TCM harness connector. Disconnect the Transmission Solenoid/Pressure Switch Assembly harness connector. Note: Check connectors - Clean/repair as necessary. Measure the resistance between ground and the L/R Pressure Switch Sense circuit. Is the resistance below 5.0 ohms? Yes → Repair the L/R Pressure Switch Sense circuit for a short to ground. Perform 42RLE TRANSMISSION VERIFICATION TEST - VER 1. No → Go To 7 | All |
| 7 | Turn the ignition off to the lock position. Disconnect the TCM harness connector. Disconnect the Transmission Solenoid/Pressure Switch Assembly harness connector. Remove the Transmission Control Relay. Note: Check connectors - Clean/repair as necessary. Connect a jumper wire between the Fused B+ circuit and the Transmission Control Relay Output circuit in the Transmission Control Relay connector. Ignition on, engine not running. Measure the voltage of the L/R Pressure Switch Sense circuit. Is the voltage above 0.5 volt? Yes → Repair the L/R Pressure Switch Sense circuit for a short to voltage. Perform 42RLE TRANSMISSION VERIFICATION TEST - VER 1. No → Go To 8 | All |
| 8 | Turn the ignition off to the lock position. Disconnect the TCM harness connector. Disconnect the Transmission Solenoid/Pressure Switch Assembly harness connector. Remove the Transmission Control Relay. Note: Check connectors - Clean/repair as necessary. Connect a jumper wire between Fused B+ circuit and the Transmission Control Relay Output circuit. Ignition on, engine not running. Using a 12-volt test light connected to ground, check the Transmission Control Relay Output circuit in the Solenoid/Pressure Switch Assembly harness connector. NOTE: The test light must illuminate brightly. Compare the brightness to that of a direct connection to the battery. Does the test light illuminate brightly? Yes → Go To 9 No → Repair the Transmission Control Relay Output circuit for an open or high resistance. Perform 42RLE TRANSMISSION VERIFICATION TEST - VER 1. | All |

P1775-SOLENOID SWITCH VALVE LATCHED IN TCC POSITION — Continued

| TEST | ACTION | APPLICABILITY |
|------|---|---------------|
| 9 | <p>Using the schematics as a guide, inspect the wiring and connectors. Repair as necessary. Pay particular attention to all power and ground circuits. If there are no possible causes remaining, view repair.</p> <p style="padding-left: 40px;">Repair</p> <p style="padding-left: 80px;">Replace the Transmission Control Module per the Service Information. WITH THE DRBIII® PERFORM QUICK LEARN. Perform 42RLE TRANSMISSION VERIFICATION TEST - VER 1.</p> | All |
| 10 | <p>The conditions necessary to set this DTC are not present at this time. Using the schematics as a guide, inspect the wiring and connectors specific to this circuit. Wiggle the wiring while checking for shorts and open circuits. With the DRBIII®, check the EATX EVENT DATA to help identify the conditions in which the DTC was set. Test drive the vehicle. Did you experience any 2nd gear launches or no TCC engagement?</p> <p style="padding-left: 40px;">Yes → Inspect the Valve Body for signs of a stuck valve or other problem in the SSV area. If no problems are found, replace the Solenoid/Pressure Switch Assembly. If excessive debris is present in the Pan or Valve Body, repair cause of the debris as necessary. Perform 42RLE TRANSMISSION VERIFICATION TEST - VER 1.</p> <p style="padding-left: 40px;">No → Test Complete.</p> | All |

Symptom:

P1776-SOLENOID SWITCH VALVE LATCHED IN LR POSITION

When Monitored and Set Condition:

P1776-SOLENOID SWITCH VALVE LATCHED IN LR POSITION

When Monitored: Continuously when doing partial or full EMCC (PEMCC or FEMCC).

Set Condition: This DTC will set if the TCM senses the L/R Pressure Switch closing while performing PEMCC or FEMCC or after two unsuccessful attempts to perform PEMCC or FEMCC.

POSSIBLE CAUSES

RELATED DTC P0841 PRESENT
 L/R PRESSURE SWITCH
 TRANSMISSION CONTROL RELAY OUTPUT CIRCUIT OPEN
 L/R PRESSURE SWITCH SENSE CIRCUIT OPEN
 L/R PRESSURE SWITCH SENSE CIRCUIT SHORT TO GROUND
 L/R PRESSURE SWITCH SENSE CIRCUIT SHORT TO VOLTAGE
 TRANSMISSION CONTROL MODULE
 INTERMITTENT WIRING AND CONNECTORS

| TEST | ACTION | APPLICABILITY |
|------|--|---------------|
| 1 | <p>NOTE: Low fluid level can be the cause of many Transmission problems. If the fluid level is low, locate and repair the leak, then check and adjust the fluid level per the Service Information.</p> <p>NOTE: Always perform diagnostics with a fully charged battery to avoid false symptoms.</p> <p>With the DRBIII®, read the engine DTC's. Check and repair all engine DTC's prior to performing Transmission Symptom Diagnostics.</p> <p>With the DRBIII®, read Transmission DTC's. Record all DTC's and 1 Trip Failures.</p> <p>NOTE: Diagnose 1 Trip Failures as a fully matured DTC.</p> <p>Using the wiring diagram/schematic as a guide, inspect the wiring and connectors. Repair as necessary.</p> <p>Perform the Shift Lever Position Test. If the test does not pass, refer to Symptom test for P0706 Check Shifter Signal.</p> <p>For Gear Ratio DTC's, check and record all CVT's.</p> <p>Most DTC's set on start up but some must be set by driving the vehicle such that all diagnostic monitors have run.</p> <p>NOTE: Verify flash level of Transmission Control Module. Some problems are corrected by software upgrades to the Transmission Control Module.</p> <p>NOTE: Check for applicable TSB's related to the symptom.</p> <p>Perform this procedure prior to Symptom diagnosis.</p> <p>Continue Go To 2</p> | All |

P1776-SOLENOID SWITCH VALVE LATCHED IN LR POSITION — Continued

| TEST | ACTION | APPLICABILITY |
|------|--|---------------|
| 2 | <p>With the DRBIII®, check for other Transmission DTCs Is the DTC P0841 present also?</p> <p>Yes → Refer to the Transmission category and perform the appropriate symptom. Perform 42RLE TRANSMISSION VERIFICATION TEST - VER 1.</p> <p>No → Go To 3</p> | All |
| 3 | <p>With the DRBIII®, Check the STARTS SINCE SET counter for P1776. NOTE: This counter only applies to the last DTC set. Is the STARTS SINCE SET counter 2 or less?</p> <p>Yes → Go To 4</p> <p>No → Go To 10</p> | All |
| 4 | <p>Turn the ignition off to the lock position. CAUTION: Remove the Starter Relay. This will prevent the vehicle from being started in gear. Install the Transmission Simulator, Miller tool #8333 and the FWD Adapter Cable kit, Miller tool #8333-1. Ignition on, engine not running. On the Transmission Simulator select L/R on the Pressure Switch selector switch. With the DRBIII®, monitor the L/R Pressure Switch state while pressing the Pressure Switch Test button on the Transmission Simulator. Did the Pressure Switch state change from OPEN to CLOSED when the test button was pressed?</p> <p>Yes → Inspect the Solenoid Switch Valve in the Valve Body per the Service Information and repair or replace as necessary. If no problems are found in Valve Body, replace the Transmission Solenoid/Pressure Switch Assembly per the Service Information. Perform 42RLE TRANSMISSION VERIFICATION TEST - VER 1.</p> <p>No → Go To 5</p> | All |
| 5 | <p>Turn the ignition off to the lock position. Disconnect the TCM harness connector. Disconnect the Transmission Solenoid/Pressure Switch Assembly harness connector. Note: Check connectors - Clean/repair as necessary. Measure the resistance of the L/R Pressure Switch Sense circuit from the TCM harness connector to the Transmission Solenoid/Pressure Switch Assembly harness connector. Is the resistance above 5.0 ohms?</p> <p>Yes → Repair the L/R Pressure Switch Sense circuit for an open. Perform 42RLE TRANSMISSION VERIFICATION TEST - VER 1.</p> <p>No → Go To 6</p> | All |

P1776-SOLENOID SWITCH VALVE LATCHED IN LR POSITION —
Continued

| TEST | ACTION | APPLICABILITY |
|------|--|---------------|
| 6 | Turn the ignition off to the lock position. Disconnect the TCM harness connector. Disconnect the Transmission Solenoid/Pressure Switch Assembly harness connector. Note: Check connectors - Clean/repair as necessary. Measure the resistance between ground and the L/R Pressure Switch Sense circuit. Is the resistance below 5.0 ohms? Yes → Repair the L/R Pressure Switch Sense circuit for a short to ground. Perform 42RLE TRANSMISSION VERIFICATION TEST - VER 1. No → Go To 7 | All |
| 7 | Turn the ignition off to the lock position. Disconnect the TCM harness connector. Disconnect the Transmission Solenoid/Pressure Switch Assembly harness connector. Remove the Transmission Control Relay from the PDC. Note: Check connectors - Clean/repair as necessary. Connect a jumper wire between the Fused B+ circuit and the Transmission Control Relay Output circuit in the Transmission Control Relay connector. Ignition on, engine not running. Measure the voltage of the L/R Pressure Switch Sense circuit. Is the voltage above 0.5 volts? Yes → Repair the L/R Pressure Switch Sense circuit for a short to voltage. Perform 42RLE TRANSMISSION VERIFICATION TEST - VER 1. No → Go To 8 | All |
| 8 | Turn the ignition off to the lock position. Disconnect the Transmission Solenoid/Pressure Switch Assembly harness connector. Remove the Transmission Control Relay. Note: Check connectors - Clean/repair as necessary. Connect a jumper wire between the Fused B+ circuit and the Transmission Control Relay Output circuit in the Transmission Control Relay connector. Ignition on, engine not running. Using a 12-volt test light connected to ground, check the Transmission Control Relay Output circuit. NOTE: The test light must illuminate brightly. Compare the brightness to that of a direct connection to the battery. Does the test light illuminate brightly? Yes → Go To 9 No → Repair the Transmission Control Relay Output circuit for an open or high resistance. Perform 42RLE TRANSMISSION VERIFICATION TEST - VER 1. | All |
| 9 | Using the schematics as a guide, inspect the wiring and connectors. Repair as necessary. Pay particular attention to all power and ground circuits. If there are no possible causes remaining, view repair. Repair Replace the Transmission Control Module per the Service Information. WITH THE DRBIII® PERFORM QUICK LEARN. Perform 42RLE TRANSMISSION VERIFICATION TEST - VER 1. | All |

P1776-SOLENOID SWITCH VALVE LATCHED IN LR POSITION — Continued

| TEST | ACTION | APPLICABILITY |
|------|--|---------------|
| 10 | <p>The conditions necessary to set this DTC are not present at this time.</p> <p>Using the schematics as a guide, inspect the wiring and connectors specific to this circuit.</p> <p>Wiggle the wiring while checking for shorts and open circuits.</p> <p>With the DRBIII®, check the EATX EVENT DATA to help identify the conditions in which the DTC was set.</p> <p>Test drive the vehicle.</p> <p>Did you experience any 2nd gear launches or no TCC engagement?</p> <p style="padding-left: 40px;">Yes → Inspect the Valve Body for signs of a stuck valve or other problem in the SSV area. If no problems are found, replace the Solenoid/Pressure Switch Assembly. If excessive debris is present in the Pan or Valve Body, repair the cause of debris as necessary. Perform 42RLE TRANSMISSION VERIFICATION TEST - VER 1.</p> <p style="padding-left: 40px;">No → Test Complete.</p> | All |

Symptom:

P1790-FAULT IMMEDIATELY AFTER SHIFT

When Monitored and Set Condition:

P1790-FAULT IMMEDIATELY AFTER SHIFT

When Monitored: After a speed ratio error is stored.

Set Condition: This code is set if the associated speed ratio code is stored within 1.3 seconds after a shift.

POSSIBLE CAUSES

CONDITION P1790 PRESENT

| TEST | ACTION | APPLICABILITY |
|------|--|---------------|
| 1 | <p>NOTE: Low fluid level can be the cause of many Transmission problems. If the fluid level is low, locate and repair the leak, then check and adjust the fluid level per the Service Information.</p> <p>NOTE: Always perform diagnostics with a fully charged battery to avoid false symptoms.</p> <p>With the DRBIII®, read the engine DTC's. Check and repair all engine DTC's prior to performing Transmission Symptom Diagnostics.</p> <p>With the DRBIII®, read Transmission DTC's. Record all DTC's and 1 Trip Failures.</p> <p>NOTE: Diagnose 1 Trip Failures as a fully matured DTC.</p> <p>Using the wiring diagram/schematic as a guide, inspect the wiring and connectors. Repair as necessary.</p> <p>Perform the Shift Lever Position Test. If the test does not pass, refer to Symptom test for P0706 Check Shifter Signal.</p> <p>For Gear Ratio DTC's, check and record all CVI's.</p> <p>Most DTC's set on start up but some must be set by driving the vehicle such that all diagnostic monitors have run.</p> <p>NOTE: Verify flash level of Transmission Control Module. Some problems are corrected by software upgrades to the Transmission Control Module.</p> <p>NOTE: Check for applicable TSB's related to the symptom.</p> <p>Perform this procedure prior to Symptom diagnosis.</p> <p>Continue Go To 2</p> | All |
| 2 | <p>This DTC is set along with a gear ratio DTC. Perform the appropriate test for the Gear Ratio DTC stored.</p> <p>NOTE: Check 1 trip failures if there are no Gear Ratio DTC's current.</p> <p>If there are no possible causes remaining, view repair.</p> <p>Repair</p> <p>Refer to the Transmission category and perform the appropriate symptom.</p> <p>Perform 42RLE TRANSMISSION VERIFICATION TEST - VER 1.</p> | All |

Symptom:**P1793-TRD LINK COMMUNICATION ERROR****When Monitored and Set Condition:****P1793-TRD LINK COMMUNICATION ERROR**

When Monitored: The transmission controller pulses the 12 volt TRD signal from the PCM to ground, during torque managed shifts with the throttle angle above 54 degrees. The TRD system is also tested whenever the vehicle is stopped and the engine speed is at idle.

Set Condition: This code is set when the Transmission Control Module (TCM) sends two subsequent torque reduction messages to the Powertrain Control Module (PCM) via the TRD link circuit and does not receive a confirmation from the PCM over the communication bus.

POSSIBLE CAUSES

RELATED DTC'S PRESENT

TORQUE MANAGEMENT REQUEST SENSE CIRCUIT OPEN

TORQUE MANAGEMENT REQUEST SENSE SHORT TO GROUND

TORQUE MANAGEMENT REQUEST SENSE CIRCUIT SHORT TO VOLTAGE

POWERTRAIN CONTROL MODULE

TRANSMISSION CONTROL MODULE

INTERMITTENT WIRING AND CONNECTORS

| TEST | ACTION | APPLICABILITY |
|------|--|---------------|
| 1 | <p>NOTE: Low fluid level can be the cause of many Transmission problems. If the fluid level is low, locate and repair the leak, then check and adjust the fluid level per the Service Information.</p> <p>NOTE: Always perform diagnostics with a fully charged battery to avoid false symptoms.</p> <p>With the DRBIII®, read the engine DTC's. Check and repair all engine DTC's prior to performing Transmission Symptom Diagnostics.</p> <p>With the DRBIII®, read Transmission DTC's. Record all DTC's and 1 Trip Failures.</p> <p>NOTE: Diagnose 1 Trip Failures as a fully matured DTC.</p> <p>Using the wiring diagram/schematic as a guide, inspect the wiring and connectors. Repair as necessary.</p> <p>Perform the Shift Lever Position Test. If the test does not pass, refer to Symptom test for P0706 Check Shifter Signal.</p> <p>For Gear Ratio DTC's, check and record all CVI's.</p> <p>Most DTC's set on start up but some must be set by driving the vehicle such that all diagnostic monitors have run.</p> <p>NOTE: Verify flash level of Transmission Control Module. Some problems are corrected by software upgrades to the Transmission Control Module.</p> <p>NOTE: Check for applicable TSB's related to the symptom.</p> <p>Perform this procedure prior to Symptom diagnosis.</p> <p>Continue Go To 2</p> | All |

P1793-TRD LINK COMMUNICATION ERROR — Continued

| TEST | ACTION | APPLICABILITY |
|------|---|---------------|
| 2 | <p>With the DRBIII®, read Transmission DTC's. Are any of the following DTCs P1694, P0731, P0732, P0733, P0734, P0736 present also?</p> <p>Yes → If any of these codes are present, disregard the P1793 DTC and refer to the Transmission category and perform the appropriate symptom. Perform 42RLE TRANSMISSION VERIFICATION TEST - VER 1.</p> <p>No → Go To 3</p> | All |
| 3 | <p>With the DRBIII®, Check the STARTS SINCE SET counter. Note: This counter only applies to the last DTC set. Is the STARTS SINCE SET equal to 0?</p> <p>Yes → Go To 4</p> <p>No → Go To 9</p> | All |
| 4 | <p>Turn the ignition off to the lock position. Disconnect the PCM harness connector. Disconnect the TCM harness connector. Note: Check connectors - Clean/repair as necessary. Measure the resistance of the Torque Management Request Sense circuit from the TCM harness connector to the PCM harness connector. Is the resistance above 5.0 ohms?</p> <p>Yes → Repair the Torque Management Request Sense circuit for an open. Perform 42RLE TRANSMISSION VERIFICATION TEST - VER 1.</p> <p>No → Go To 5</p> | All |
| 5 | <p>Turn the ignition off to the lock position. Disconnect the PCM harness connector. Disconnect the TCM harness connector. Note: Check connectors - Clean/repair as necessary. Measure the resistance between ground and the Torque Management Request Sense circuit. Is the resistance below 5.0 ohms?</p> <p>Yes → Repair Torque Management Request Sense circuit for a short to ground. Perform 42RLE TRANSMISSION VERIFICATION TEST - VER 1.</p> <p>No → Go To 6</p> | All |
| 6 | <p>Turn the ignition off to the lock position. Disconnect the TCM harness connector. Ignition on, engine not running. Measure the voltage of the Torque Management Request Sense circuit. Is the voltage above 10.5 volts?</p> <p>Yes → Repair Torque Management Request Sense circuit for a short to voltage. Perform 42RLE TRANSMISSION VERIFICATION TEST - VER 1.</p> <p>No → Go To 7</p> | All |

P1793-TRD LINK COMMUNICATION ERROR — Continued

| TEST | ACTION | APPLICABILITY |
|------|---|---------------|
| 7 | Turn the ignition off to the lock position. Disconnect the TCM harness connector. Ignition on, engine not running. Measure the voltage of the Torque Management Request Sense circuit in the TCM harness connector. Is the voltage above 7.0 volts? Yes → Replace the Transmission Control Module per the Service Information. WITH THE DRBIII® PERFORM QUICK LEARN. Perform 42RLE TRANSMISSION VERIFICATION TEST - VER 1. No → Go To 8 | All |
| 8 | If there are no possible causes remaining, view repair. Repair Replace and program the Powertrain Control Module per the Service Information. Perform 42RLE TRANSMISSION VERIFICATION TEST - VER 1. | All |
| 9 | The conditions necessary to set this DTC are not present at this time. Using the schematics as a guide, inspect the wiring and connectors specific to this circuit. Wiggle the wiring while checking for shorts and open circuits. With the DRBIII®, check the EATX EVENT DATA to help identify the conditions in which the DTC was set. Were there any problems found? Yes → Repair as necessary. Perform 42RLE TRANSMISSION VERIFICATION TEST - VER 1. No → Test Complete. | All |

Symptom:

P1794-SPEED SENSOR GROUND ERROR

When Monitored and Set Condition:

P1794-SPEED SENSOR GROUND ERROR

When Monitored: The transmission gear ratio is monitored continuously while the transmission is in gear.

Set Condition: After a TCM reset in neutral and Input/Output speed ratio equals a ratio of input to output of 2.5 to 1.

POSSIBLE CAUSES

SPEED SENSOR GROUND CIRCUIT OPEN
 TRANSMISSION CONTROL MODULE
 INTERMITTENT WIRING AND CONNECTORS

| TEST | ACTION | APPLICABILITY |
|----------|--|---------------|
| <p>1</p> | <p>NOTE: Low fluid level can be the cause of many Transmission problems. If the fluid level is low, locate and repair the leak, then check and adjust the fluid level per the Service Information. NOTE: Always perform diagnostics with a fully charged battery to avoid false symptoms. With the DRBIII®, read the engine DTC's. Check and repair all engine DTC's prior to performing Transmission Symptom Diagnostics. With the DRBIII®, read Transmission DTC's. Record all DTC's and 1 Trip Failures. NOTE: Diagnose 1 Trip Failures as a fully matured DTC. Using the wiring diagram/schematic as a guide, inspect the wiring and connectors. Repair as necessary. Perform the Shift Lever Position Test. If the test does not pass, refer to Symptom test for P0706 Check Shifter Signal. For Gear Ratio DTC's, check and record all CVI's. Most DTC's set on start up but some must be set by driving the vehicle such that all diagnostic monitors have run. NOTE: Verify flash level of Transmission Control Module. Some problems are corrected by software upgrades to the Transmission Control Module. NOTE: Check for applicable TSB's related to the symptom. Perform this procedure prior to Symptom diagnosis.</p> <p style="text-align: center;">Continue Go To 2</p> | <p>All</p> |
| <p>2</p> | <p>Start the engine in park. With the DRBIII®, observe the Input and Output Speed Sensor readings. Is the Output Speed Sensor reading twice the Input Speed Sensor reading?</p> <p style="text-align: center;">Yes → Go To 3 No → Go To 6</p> | <p>All</p> |

P1794-SPEED SENSOR GROUND ERROR — Continued

| TEST | ACTION | APPLICABILITY |
|------|---|---------------|
| 3 | <p>Turn the ignition off to the lock position. CAUTION: Remove the Starter Relay. This will prevent the vehicle from being started in gear. Install the Transmission Simulator, Miller tool #8333 and the Electronic Transmission Adapter kit 8333-1. Ignition on, engine not running. Using the Transmission Simulator, set the selector switch to the 3000/1250 position. Turn the Input/Output switch to ON. With the DRBIII®, read the Input and Output Speed Sensor RPM. Does the Input Speed read 3000 RPM and the Output Speed read 1250 RPM within 50 RPM?</p> <p style="padding-left: 40px;">Yes → Go To 5 No → Go To 4</p> | All |
| 4 | <p>Turn the ignition off to the lock position. Disconnect Input and Output Speed Sensor harness connectors. Disconnect the TRS harness connector. Note: Check connectors - Clean/repair as necessary. Measure the resistance of the Speed Sensor Ground circuit from the TCM harness connector to the Input and Output Speed Sensor harness connectors. Is the resistance above 5.0 ohms on either Speed Sensor Ground circuit?</p> <p style="padding-left: 40px;">Yes → Repair the Speed Sensor Ground circuit for an open or high resistance. Perform 42RLE TRANSMISSION VERIFICATION TEST - VER 1. No → Go To 5</p> | All |
| 5 | <p>Using the schematics as a guide, inspect the wiring and connectors. Repair as necessary. Pay particular attention to all power and ground circuits. If there are no possible causes remaining, view repair.</p> <p style="padding-left: 40px;">Repair Replace the Transmission Control Module per the Service Information. WITH THE DRBIII® PERFORM QUICK LEARN. Perform 42RLE TRANSMISSION VERIFICATION TEST - VER 1.</p> | All |
| 6 | <p>The conditions necessary to set this DTC are not present at this time. Using the schematics as a guide, inspect the wiring and connectors specific to this circuit. Wiggle the wiring while checking for shorts and open circuits. With the DRBIII®, check the EATX EVENT DATA to help identify the conditions in which the DTC was set. Were there any problems found?</p> <p style="padding-left: 40px;">Yes → Repair as necessary. Perform 42RLE TRANSMISSION VERIFICATION TEST - VER 1. No → Test Complete.</p> | All |

Symptom:
P1797-MANUAL SHIFT OVERHEAT

When Monitored and Set Condition:

P1797-MANUAL SHIFT OVERHEAT

When Monitored: Whenever engine is running and transmission is in the AutoStick mode.

Set Condition: If the engine temperature exceeds 124° C or 255° F or the transmission temperature exceeds 135° C or 275° F while in AutoStick mode. Note: Aggressive driving or driving in low for extended periods of time in AutoStick® mode will set this DTC.

POSSIBLE CAUSES

MANUAL SHIFT OVERHEAT

| TEST | ACTION | APPLICABILITY |
|------|--|---------------|
| 1 | <p>NOTE: Low fluid level can be the cause of many Transmission problems. If the fluid level is low, locate and repair the leak, then check and adjust the fluid level per the Service Information.</p> <p>NOTE: Always perform diagnostics with a fully charged battery to avoid false symptoms.</p> <p>With the DRBIII®, read the engine DTC's. Check and repair all engine DTC's prior to performing Transmission Symptom Diagnostics.</p> <p>With the DRBIII®, read Transmission DTC's. Record all DTC's and 1 Trip Failures.</p> <p>NOTE: Diagnose 1 Trip Failures as a fully matured DTC.</p> <p>Using the wiring diagram/schematic as a guide, inspect the wiring and connectors. Repair as necessary.</p> <p>Perform the Shift Lever Position Test. If the test does not pass, refer to Symptom test for P0706 Check Shifter Signal.</p> <p>For Gear Ratio DTC's, check and record all CVI's.</p> <p>Most DTC's set on start up but some must be set by driving the vehicle such that all diagnostic monitors have run.</p> <p>NOTE: Verify flash level of Transmission Control Module. Some problems are corrected by software upgrades to the Transmission Control Module.</p> <p>NOTE: Check for applicable TSB's related to the symptom.</p> <p>Perform this procedure prior to Symptom diagnosis.</p> <p style="text-align: center;">Continue Go To 2</p> | All |

P1797-MANUAL SHIFT OVERHEAT — Continued

| TEST | ACTION | APPLICABILITY |
|------|--|---------------|
| 2 | <p>This is an informational DTC only.</p> <p>Check the Engine and Transmission Cooling Systems for proper operation.</p> <p>Check the Radiator Cooling Fan operation.</p> <p>Check the Transmission Cooling Fan operation if equipped.</p> <p>Check the Transmission Fluid Level. Make sure it is not overfilled.</p> <p>NOTE: Aggressive driving or driving in low for extended periods of time in Autostick® mode will set this DTC.</p> <p>With the DRBIII®, check the EATX EVENT DATA to help identify the conditions in which the DTC was set.</p> <p>Were there any problems found?</p> <p> Yes → Repair as necessary. Perform 42RLE TRANSMISSION VERIFICATION TEST - VER 1.</p> <p> No → Test Complete.</p> | All |

Symptom:

***BACKUP LAMPS COME ON WHILE SHIFTER IS NOT IN REVERSE POSITION**

POSSIBLE CAUSES

BACKUP LAMPS ALWAYS ON
 BACKUP LAMP SUPPLY CIRCUIT SHORT TO VOLTAGE
 INTERMITTENT WIRING AND CONNECTORS

| TEST | ACTION | APPLICABILITY |
|------|---|---------------|
| 1 | Ignition on, engine not running. Firmly apply brakes. Place the shift lever in the position which causes the Backup Lamps to come on other than Reverse. Do the Backup Lamps come on with the shift lever not in the Reverse position? Yes → Go To 2 No → Go To 4 | All |
| 2 | Ignition on, engine not running. Place the Shift Lever in the position that causes the Backup Lamps to come on other than Reverse. Disconnect the TRS harness connector. NOTE: This will cause a DTC P0706 and possibly other DTC's to be stored in the TCM. They must be erased before returning the vehicle to the customer. Did the Backup Lamps go out when the TRS harness connector was disconnected? Yes → Replace the Transmission Range Sensor per the Service Information. Perform TRANSMISSION NO TROUBLE CODE VERIFICATION TEST. No → Go To 3 | All |
| 3 | Turn the ignition off to the lock position. Disconnect the Transmission TRS harness connector. NOTE: Check connectors - Clean/repair as necessary. Ignition on, engine not running. Measure the voltage of the Back-up Lamp Supply circuit in the TCM harness connector. Is the voltage above 0.5 volt? Yes → Repair the Backup Lamp Supply circuit for a short to voltage. Perform TRANSMISSION NO TROUBLE CODE VERIFICATION TEST. No → Test Complete. | All |

***BACKUP LAMPS COME ON WHILE SHIFTER IS NOT IN REVERSE POSITION — Continued**

| TEST | ACTION | APPLICABILITY |
|------|---|---------------|
| 4 | <p>The condition is not present at this time. Using the schematics as a guide, inspect the wiring and connectors specific to this circuit. Wiggle the wiring while checking for shorts and open circuits. Were there any problems found?</p> <p>Yes → Repair as necessary. Perform TRANSMISSION NO TROUBLE CODE VERIFICATION TEST.</p> <p>No → Test Complete.</p> | All |

Symptom:

*BACKUP LAMPS INOPERATIVE

POSSIBLE CAUSES

OPEN LEFT BACKUP LAMP BULB
 OPEN RIGHT BACKUP LAMP BULB
 BACKUP LAMP GROUND CIRCUIT OPEN
 BACKUP LAMP SUPPLY CIRCUIT OPEN
 FUSED IGNITION SWITCH OUTPUT CIRCUIT OPEN
 BACKUP LAMP SUPPLY CIRCUIT SHORT TO GROUND
 TRANSMISSION RANGE SENSOR
 INTERMITTENT WIRING AND CONNECTORS

| TEST | ACTION | APPLICABILITY |
|------|--|---------------|
| 1 | Ignition on, engine not running. Place foot firmly on brake pedal. Place the shift lever in the reverse position. Do either of the Backup Lamps work? Yes → Go To 2 No → Go To 3 | All |
| 2 | The condition is not present at this time. Using the schematics as a guide, inspect the wiring and connectors specific to this circuit. Wiggle the wiring while checking for shorts and open circuits. Were there any problems found? Yes → Repair as necessary. Perform TRANSMISSION NO TROUBLE CODE VERIFICATION TEST. No → Test Complete. | All |
| 3 | Remove the left Backup Lamp bulb. Measure the resistance of the Backup Lamp bulb. Is the resistance above 5.0 ohms? Yes → Replace the Backup Lamp bulb. Perform TRANSMISSION NO TROUBLE CODE VERIFICATION TEST. No → Go To 4 | All |
| 4 | Remove the right Backup Lamp bulb. Measure the resistance of the Backup Lamp bulb. Is the resistance above 5.0 ohms? Yes → Replace the Backup Lamp bulb. Perform TRANSMISSION NO TROUBLE CODE VERIFICATION TEST. No → Go To 5 | All |

***BACKUP LAMPS INOPERATIVE — Continued**

| TEST | ACTION | APPLICABILITY |
|------|---|---------------|
| 5 | Turn the ignition off to the lock position. CAUTION: Remove the Starter Relay. This will prevent the vehicle from being started in gear. Install the Transmission Simulator, Miller tool #8333 and the FWD Adapter Cable kit, Miller tool #8333-1. Ignition on, engine not running. Press the "Reverse Light Test" button on the Transmission Simulator while observing the backup lamps. Do either of the back-up lamps come on? Yes → Go To 6 No → Go To 7 | All |
| 6 | If there are no possible causes remaining, view repair. Repair Replace Transmission Range Sensor per the Service Information. Perform TRANSMISSION NO TROUBLE CODE VERIFICATION TEST. | All |
| 7 | Remove the Backup Lamp bulb. Using a 12-volt test light connected to 12-volts, check the Backup Lamp Ground circuit in the Backup Lamp socket. NOTE: The test light must illuminate brightly. Compare the brightness to that of a direct connection to the battery. Does the test light illuminate brightly? Yes → Go To 8 No → Repair the Backup Lamp Ground circuit for an open or high resistance. Perform TRANSMISSION NO TROUBLE CODE VERIFICATION TEST. | All |
| 8 | Turn the ignition off to the lock position. Remove the Backup Lamp bulb. Disconnect the Transmission TRS harness connector. Note: Check connectors - Clean/repair as necessary. Measure the resistance of the Backup Lamp Supply circuit from the Backup Lamp Socket to the TRS harness connector. Is the resistance above 5.0 ohms? Yes → Repair the Backup Lamp Supply circuit for an open. Perform TRANSMISSION NO TROUBLE CODE VERIFICATION TEST. No → Go To 9 | All |

***BACKUP LAMPS INOPERATIVE — Continued**

| TEST | ACTION | APPLICABILITY |
|------|--|---------------|
| 9 | Turn the ignition off to the lock position. Disconnect the Transmission TRS harness connector. Ignition on, engine not running. Using a 12-volt test light connected to ground, check the Fused Ignition Switch Output circuit in the TRS harness connector. NOTE: The test light must illuminate brightly. Compare the brightness to that of a direct connection to the battery. Does the test light illuminate brightly? Yes → Go To 10 No → Repair the Fused Ignition Switch Output circuit for an open. If the fuse is open make sure to check for a short to ground. Perform TRANSMISSION NO TROUBLE CODE VERIFICATION TEST. | All |
| 10 | Turn ignition off to the lock position. Remove the Backup Lamp bulb. Disconnect the Transmission TRS harness connector. Note: Check connectors - Clean/repair as necessary. Measure the resistance between ground and the Backup Lamp Supply circuit. Is the resistance below 5.0 ohms? Yes → Repair Backup Lamp Supply circuit for a short to ground. Check the fuse and replace if necessary. Perform TRANSMISSION NO TROUBLE CODE VERIFICATION TEST. No → Test Complete. | All |

Symptom:***CHECKING PARK/NEUTRAL SWITCH OPERATION****POSSIBLE CAUSES**

P/N POSITION SWITCH SENSE CIRCUIT OPEN
 P/N POSITION SWITCH SENSE CIRCUIT SHORTED TO GROUND
 TRANSMISSION RANGE SENSOR
 PCM - P/N POSITION SWITCH

| TEST | ACTION | APPLICABILITY |
|------|---|---------------|
| 1 | Turn the ignition on. With the DRBIII®, read the Park/Neutral Position Switch input state. While moving the gear selector through all gear positions, Park to 1 and back to Park, watch the DRBIII® display. Did the DRBIII® display show P/N and D/R in the correct gear positions? Yes → Test Complete. No → Go To 2 | All |
| 2 | Turn the ignition off. Disconnect the PCM harness connectors. Disconnect the Transmission Range Sensor harness connector. Note: Check connectors - Clean/repair as necessary. Measure the resistance of the P/N Position Switch Sense circuit. Is the resistance below 5.0 ohms? Yes → Go To 3 No → Repair the P/N Position Switch Sense circuit for an open. Perform TRANSMISSION NO TROUBLE CODE VERIFICATION TEST. | All |
| 3 | Turn the ignition off. Disconnect the PCM harness connectors. Disconnect the Transmission Range Sensor harness connector. Note: Check connectors - Clean/repair as necessary. Measure the resistance between ground and the P/N Position Switch Sense circuit. Is the resistance above 100k ohms? Yes → Go To 4 No → Repair the P/N Position Switch Sense circuit for a short to ground. Perform TRANSMISSION NO TROUBLE CODE VERIFICATION TEST. | All |

***CHECKING PARK/NEUTRAL SWITCH OPERATION — Continued**

| TEST | ACTION | APPLICABILITY |
|------|--|---------------|
| 4 | Turn the ignition off. Disconnect the PCM harness connectors. Move the Gear selector through all gear positions, from Park to 1st and back. While moving the gear selector through each gear, measure the resistance between ground and the P/N Position Switch Sense circuit. Did the resistance change from above 10.0 ohms to below 10.0 ohms? Yes → Go To 5 No → Replace the Transmission Range Sensor. Perform TRANSMISSION NO TROUBLE CODE VERIFICATION TEST. | All |
| 5 | If there are no possible causes remaining, view repair. Repair Replace and program the Powertrain Control Module per the Service Information. Perform POWERTRAIN VERIFICATION TEST VER - 2. | All |

Symptom:***INCORRECT TRANSMISSION FLUID LEVEL****POSSIBLE CAUSES**

INCORRECT FLUID LEVEL

| TEST | ACTION | APPLICABILITY |
|-------------|---|----------------------|
| 1 | <p>The transmission must be above 70 degree F. prior to checking fluid level. Adjusting fluid level on a cold transmission will result in an overfilled transmission. Check the transmission fluid level per the service information. Is the fluid level OK?</p> <p>Yes → Test Complete.</p> <p>No → Adjust fluid level. Repair cause of incorrect fluid level. Perform TRANSMISSION NO TROUBLE CODE VERIFICATION TEST.</p> | All |

Symptom:

***NO SPEEDOMETER OPERATION**

POSSIBLE CAUSES

NO SPEEDOMETER OPERATION

| TEST | ACTION | APPLICABILITY |
|------|---|---------------|
| 1 | With the DRBIII®, check the pinion factor setting in the TCM. Is the pinion factor missing or set incorrectly? Yes → One possible cause is the pinion factor is not set or is set incorrectly in the TCM. Perform 42RLE TRANSMISSION VERIFICATION TEST - VER 1. No → Test Complete. | All |

Symptom:***TRANSMISSION NOISY WITH NO DTC'S PRESENT****POSSIBLE CAUSES**

INCORRECT FLUID LEVEL

INTERNAL TRANSMISSION PROBLEM - NOISY

INTERNAL TRANSMISSION PROBLEM - NOISY WHILE STANDING STILL

| TEST | ACTION | APPLICABILITY |
|-------------|--|----------------------|
| 1 | <p>Check the Transmission Fluid Level per the Service Information. Is the fluid level OK?</p> <p>Yes → Go To 2</p> <p>No → Adjust fluid level and repair cause of incorrect fluid level. Perform TRANSMISSION NO TROUBLE CODE VERIFICATION TEST.</p> | All |
| 2 | <p>Place vehicle on hoist. WARNING: BE SURE TO KEEP HANDS AND FEET CLEAR OF ROTATING WHEELS. Run vehicle on hoist under conditions necessary to duplicate the noise. NOTE: It may be necessary to test drive the vehicle to duplicate the noise. Using Chassis Ears or other suitable listening device, verify the source of the noise. Is the noise coming from the transmission?</p> <p>Yes → Go To 3</p> <p>No → Test Complete.</p> | All |
| 3 | <p>With the shift lever in neutral, raise the engine speed and listen to the noise. NOTE: THE RADIO MUST BE TURNED OFF. Alternator noise can come through the speakers and be misinterpreted as Transmission Pump Whine. This can happen even with the volume turned down. Does the noise get louder or change pitch while the engine speed is changing?</p> <p>Yes → Go To 4</p> <p>No → Go To 5</p> | All |
| 4 | <p>If there are no possible causes remaining, view repair.</p> <p>Repair</p> <p>Repair internal transmission problem as necessary. Inspect all of the transmission components for signs of wear. If no problems found, replace the Transmission oil pump.. Perform TRANSMISSION NO TROUBLE CODE VERIFICATION TEST.</p> | All |
| 5 | <p>If there are no possible causes remaining, view repair.</p> <p>Repair</p> <p>Repair internal transmission problem as necessary. Inspect all of the transmission components for signs of wear. Pay particular attention to bearings, pinion gears, etc. Repair or replace as necessary. Perform TRANSMISSION NO TROUBLE CODE VERIFICATION TEST.</p> | All |

Symptom:

***TRANSMISSION SHIFTS EARLY WITH NO DTC'S**

| POSSIBLE CAUSES |
|---|
| BUS PROBLEMS CHECK FOR INTERMITTENT WIRING & CONNECTORS COLD TRANSMISSION |

| TEST | ACTION | APPLICABILITY |
|------|--|---------------|
| 1 | Using the DRBIII®, check all other Modules for signs of a PCI bus problem such as bus related DTC's and/or communication problems. Check and diagnose all 1 trip failures as a hard code. Although it takes two occurrences of a missed TRD link message to set the DTC P1793, one missed message will cause the transmission to short shift until the next start up. If the vehicle has any indications of a bus problem, the bus must be repaired first Do any of the other modules show signs of a bus problem? Yes → Repair the PCI bus problem. Perform 42RLE TRANSMISSION VERIFICATION TEST - VER 1. No → Go To 2 | All |
| 2 | <p>NOTE: If the Transmission shifts too early when the Transmission is cold, this is a normal condition. The software is designed to protect the Transmission from high torque and/or high RPM shifts during cold operation.</p> Did the problem occur when the Transmission temperature was cold? Yes → This is a normal condition. Perform 42RLE TRANSMISSION VERIFICATION TEST - VER 1. No → Go To 3 | All |
| 3 | The conditions necessary to set the DTC are not present at this time. Using the schematics as a guide, inspect the wiring and connectors. Wiggle the wires while checking for shorts and open circuits. Although it takes two occurrences of a missed TRD link message to set the DTC P1793, one missed message will cause the transmission to short shift until the next start up. If the vehicle has any indications of a bus problem, the bus must be repaired first Were any problems found? Yes → Repair wiring and/or connector as necessary. Perform 42RLE TRANSMISSION VERIFICATION TEST - VER 1. No → Test Complete. | All |

Symptom:***TRANSMISSION SIMULATOR 8333 WILL NOT POWER UP**

| TEST | ACTION | APPLICABILITY |
|------|--|---------------|
| 1 | <p>NOTE: If the Transmission Simulator Miller tool #8333 will not power up, this is a symptom of the Transmission Relay being open, such as Limp-in, and/or this also could be a indication of the Transmission Simulator not installed correctly on the vehicle.</p> <p>NOTE: Check the Simulator ground cable connection.</p> <p>NOTE: Check all Transmission Simulator harness connections.</p> <p>Repair these symptoms before having the Transmission Simulator Miller Tool #8333 repaired.</p> <p>Continue Test Complete.</p> | All |

Verification Tests

| 42RLE TRANSMISSION VERIFICATION TEST - VER 1 | APPLICABILITY |
|---|---------------|
| <p>1. Connect the DRBIII® to the Data Link Connector (DLC).</p> <p>2. Reconnect any disconnected components.</p> <p>3. With the DRBIII®, erase all Transmission DTC's, also erase the PCM DTC's.</p> <p>4. NOTE: Erase DTC P0700 in the PCM to turn the Malfunction Indicator Lamp (MIL) off after making Transmission repairs.</p> <p>5. With the DRBIII®, display Transmission Temperature. Start and run the engine until the Transmission Temperature is HOT - above 43° C or 110° F.</p> <p>6. Check the Transmission Fluid and adjust if necessary. Refer to the Service information for the Fluid Fill procedure.</p> <p>7. NOTE: If the Transmission Control Module or the Transmission has been repaired or replaced it is necessary to perform the DRBIII® Quick Learn Procedure and reset the "Pinion Factor"</p> <p>8. Road test the vehicle. With the DRBIII®, monitor the engine RPM. Make 15 to 20 1-2, 2-3, 3-4 upshifts. Perform these shifts from a standing start to 45 MPH with a constant throttle opening of 20 to 25 degrees.</p> <p>9. Below 25 MPH, make 5 to 8 wide open throttle kickdowns to 1st gear. Allow at least 5 seconds each in 2nd and 3rd gear between each kickdown.</p> <p>10. For a specific DTC, drive the vehicle to the Symptom's When Monitored/When Set conditions to verify the DTC repair.</p> <p>11. If equipped with AutoStick®, up-shift and down-shift several times using the AutoStick® feature during the road test.</p> <p>12. NOTE: Use the EATX OBDII Task Manager to run Good Trip time in each gear, this will confirm the repair and to ensure that the DTC has not re-matured.</p> <p>13. Check for Diagnostic Trouble Codes (DTC's) during the road test. If a DTC sets during the road test , return to the Symptom list and perform the appropriate Symptom.</p> <p>Were there any Diagnostic Trouble Codes (DTCs) set during the road test?</p> <p>Yes → Refer to the Symptom List for appropriate Symptom(s).</p> <p>No → Repair is complete.</p> | <p>All</p> |

Verification Tests — Continued

| POWERTRAIN VERIFICATION TEST VER - 2 | APPLICABILITY |
|---|----------------------|
| <p>1. Inspect the vehicle to ensure that all engine components are properly installed and connected. Reassemble and reconnect components as necessary.</p> <p>2. If this verification procedure is being performed after a NO TROUBLE CODE repair, perform steps 3 and 4.</p> <p>3. Check to see if the initial symptom still exists. If there are no trouble codes or the symptom no longer exists, the repair was successful and testing is complete.</p> <p>4. If the initial or another symptom exists, the repair is not complete. Check all technical service bulletins or flash updates and return to Symptoms if necessary.</p> <p>5. If this verification procedure is being performed after a DTC repair, perform steps 6 through 13.</p> <p>6. Connect the DRBIII® to the data link connector. Using the DRBIII® erase any diagnostic trouble codes and reset all values.</p> <p>7. If the PCM was not replaced, skip steps 8 through 10, then proceed with the verification.</p> <p>8. If the PCM was replaced the correct VIN and mileage must be programmed or a DTC will set in the ABS and Air Bag modules. In addition, if the vehicle is equipped with Sentry Key Immobilizer System (SKIS), Secret Key data must be updated to enable start.</p> <p>9. For ABS and Air Bag systems: Enter correct VIN and Mileage in PCM. Erase codes in ABS and Air Bag modules.</p> <p>10. For SKIS theft alarm: Connect DRBIII® to data link conn. Go to Theft Alarm, SKIM, and Misc. Place SKIM in secured access mode by using the correct PIN code for this vehicle. Select Update the Secret Key data. Data will be transferred from SKIM to PCM.</p> <p>11. Road test the vehicle. If the test is for an A/C DTC, ensure it is operating during the following test.</p> <p>12. Drive the vehicle for at least 5 minutes at 64 Km/h (40 mph). Ensure the transmission shifts properly through all gears. At some point stop the vehicle and turn off the engine for at least 10 seconds.</p> <p>13. With the DRBIII®, read DTCs.</p> <p>Are any DTCs or symptoms remaining?</p> <p>Yes → Check for any related Technical Service Bulletins and/or refer to the appropriate Symptom list (Diagnostic Procedure).</p> <p>No → Repair is complete.</p> | <p>All</p> |

| TRANSMISSION NO TROUBLE CODE VERIFICATION TEST | APPLICABILITY |
|---|----------------------|
| <p>1. Inspect the vehicle to ensure that all engine and transmission components are properly installed and connected. Assemble and connect components as necessary.</p> <p>2. Check if the initial symptom still exists. If the symptom still exists, return to the symptom list and perform the appropriate symptom. Make sure to check for any Technical Service Bulletins that may apply.</p> <p>3. With the DRBIII®, erase any erroneous DTCs that may have been set due to a test procedure.</p> <p>Does the symptom still exist?</p> <p>Yes → Repair is not complete, refer to appropriate symptom.</p> <p>No → Repair is complete.</p> | <p>All</p> |

8.0 COMPONENT LOCATIONS

8.1 POWERTRAIN CONTROL MODULE

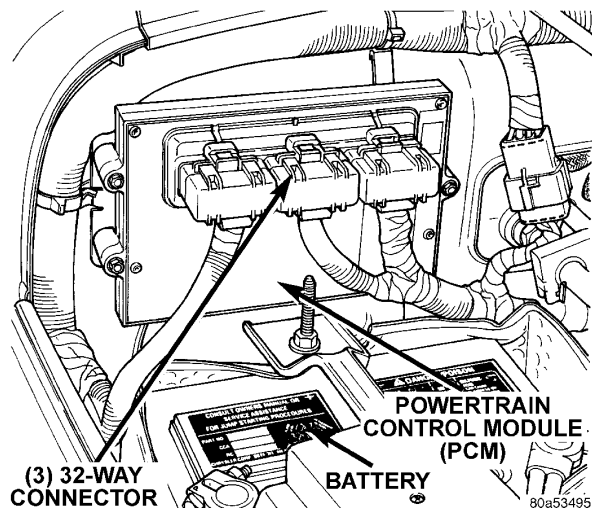

8.2 INPUT/OUTPUT SPEED SENSORS/TRS COMPONENT LOCATIONS

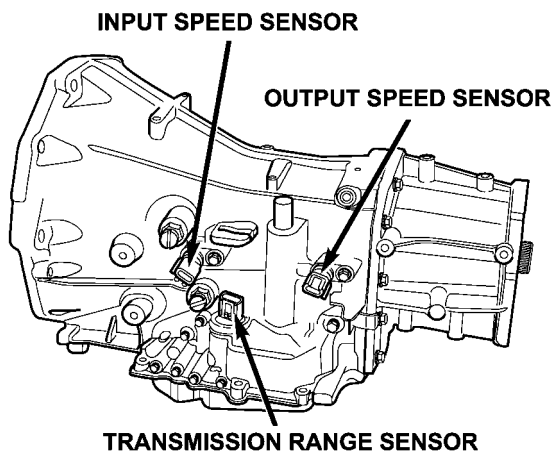

8.3 TRANSMISSION CONTROL MODULE

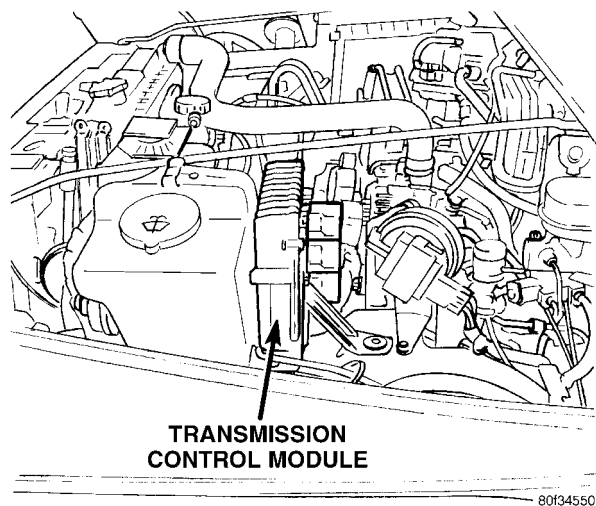

COMPONENT LOCATIONS

8.4 TRANSMISSION SOLENOID/PRESSURE SWITCH ASSEMBLY

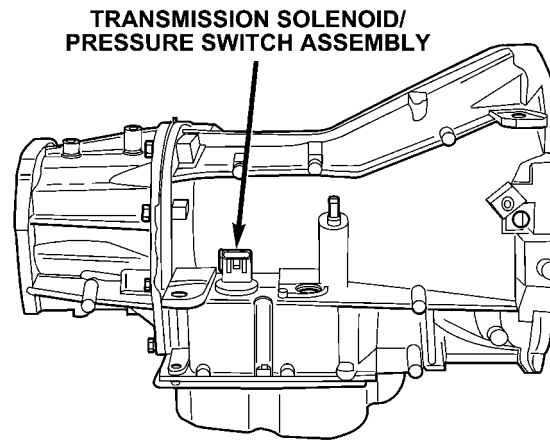

80f56398

9.0 CONNECTOR PINOUTS

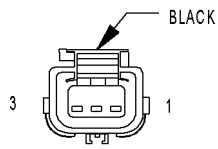

CRANKSHAFT POSITION SENSOR (2.4L/4.0L A/T)

CRANKSHAFT POSITION SENSOR (2.4L/4.0L A/T) - BLACK 3 WAY

| CAV | CIRCUIT | FUNCTION |
|-----|--------------------|-----------------------------------|
| 1 | K24 18GY/BK (2.4L) | CRANKSHAFT POSITION SENSOR SIGNAL |
| 1 | K7 200R (4.0L) | 5V SUPPLY |
| 2 | K4 20BK/LB | SENSOR GROUND 1 |
| 2 | K4 18BK/LB (2.4L) | SENSOR GROUND 1 |
| 3 | K7 180R (2.4L) | 5V SUPPLY |
| 3 | K24 18GY/BK (4.0L) | CRANKSHAFT POSITION SENSOR SIGNAL |

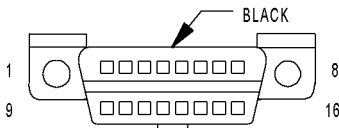

DATA LINK CONNECTOR

DATA LINK CONNECTOR - BLACK 16 WAY

| CAV | CIRCUIT | FUNCTION |
|-----|-------------|----------------------|
| 1 | - | - |
| 2 | D25 20VT/YL | PCI BUS |
| 3 | - | - |
| 4 | Z2 20BK/LG | GROUND |
| 5 | Z12 20BK/TN | GROUND |
| 6 | D32 20LG/WT | SCI RECEIVE |
| 7 | D21 20PK | SCI TRANSMIT |
| 8 | - | - |
| 9 | D23 20WT/BR | FLASH PROGRAM ENABLE |
| 10 | - | - |
| 11 | - | - |
| 12 | - | - |
| 13 | - | - |
| 14 | D20 20LG/PK | SCI RECEIVE |
| 15 | - | - |
| 16 | M1 20PK/WT | FUSED B(+) |

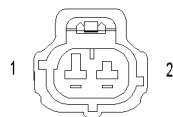

INPUT SPEED SENSOR

INPUT SPEED SENSOR - 2 WAY

| CAV | CIRCUIT | FUNCTION |
|-----|-------------|---------------------------|
| 1 | T52 18RD/BK | INPUT SPEED SENSOR SIGNAL |
| 2 | T13 18DB/BK | SPEED SENSOR GROUND |

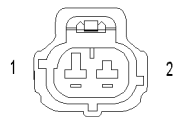

OUTPUT SPEED SENSOR

OUTPUT SPEED SENSOR - 2 WAY

| CAV | CIRCUIT | FUNCTION |
|-----|-------------|----------------------------|
| 1 | T14 18LG/WT | OUTPUT SPEED SENSOR SIGNAL |
| 2 | T13 18DB/BK | SPEED SENSOR GROUND |

CONNECTOR PINOUTS

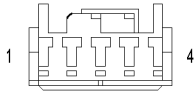

OVERDRIVE
OFF
SWITCH

OVERDRIVE OFF SWITCH - 4 WAY

| CAV | CIRCUIT | FUNCTION |
|-----|-------------|--------------------------------|
| 1 | Z1 20BK | GROUND |
| 2 | T6 18OR/WT | OVERDRIVE OFF SWITCH SENSE |
| 3 | T56 18DG/LB | OVERDRIVE OFF SWITCH INDICATOR |
| 4 | E2 20OR | PANEL LAMPS FEED |

POWER DISTRIBUTION CENTER

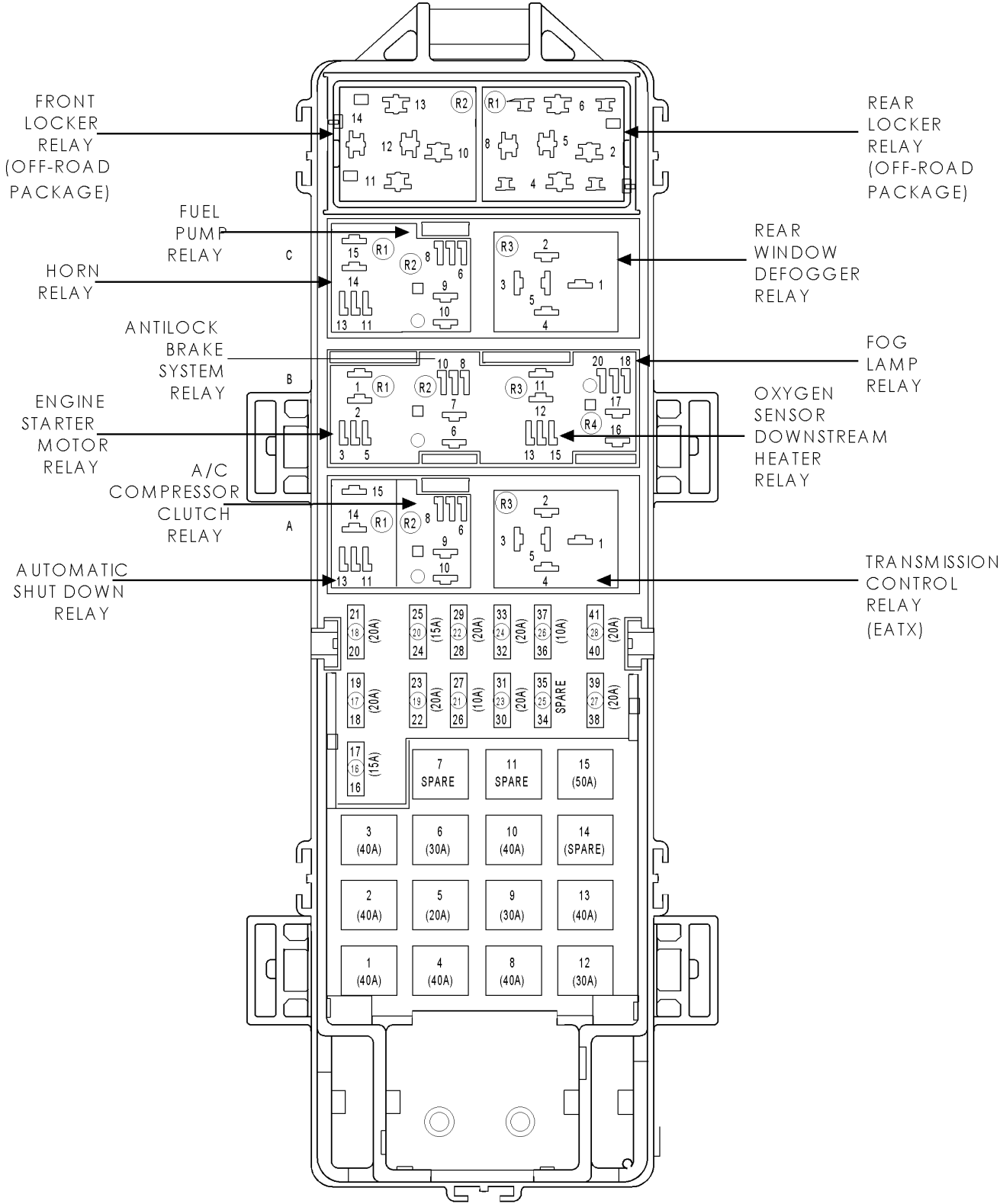

CONNECTOR PINOUTS

TRANSMISSION CONTROL RELAY (IN PDC)

| CAV | CIRCUIT | FUNCTION |
|-----|--------------------------------|------------------------------------|
| A1 | A30 16RD/WT | FUSED B(+) |
| A1 | A30 16RD/WT (OFF-ROAD PACKAGE) | FUSED B(+) |
| A2 | K30 18PK | TRANSMISSION CONTROL RELAY CONTROL |
| A3 | T16 16RD | TRANSMISSION CONTROL RELAY OUTPUT |
| A4 | Z1 18BK | GROUND |
| A5 | - | - |

POWERTRAIN CONTROL MODULE C1 - BLACK 32 WAY

| CAV | CIRCUIT | FUNCTION |
|-----|---|--|
| 1 | K18 18RD/YL (4.0L) | IGNITION COIL NO. 3 DRIVER |
| 2 | F15 18DB/WT | FUSED IGNITION SWITCH OUTPUT (RUN-START) |
| 3 | - | - |
| 4 | K4 18BK/LB | SENSOR GROUND 1 |
| 5 | - | - |
| 6 | T41 18BK/WT | PARK/NEUTRAL POSITION SWITCH SENSE |
| 7 | K19 18BK/GY | IGNITION COIL NO. 1 DRIVER |
| 8 | K24 18GY/BK | CRANKSHAFT POSITION SENSOR SIGNAL |
| 9 | - | - |
| 10 | K60 18YL/BK | IDLE AIR CONTROL NO. 2 DRIVER |
| 11 | K40 18BR/WT | IDLE AIR CONTROL NO. 3 DRIVER |
| 12 | K10 18DB/OR (2.4L) | POWER STEERING PRESSURE SWITCH SENSE |
| 13 | T141 18YL/RD | FUSED IGNITION SWITCH OUTPUT (START) |
| 14 | - | - |
| 15 | K21 18BK/RD | INTAKE AIR TEMPERATURE SENSOR SIGNAL |
| 16 | K2 18TN/BK | ENGINE COOLANT TEMPERATURE SENSOR SIGNAL |
| 17 | K7 18OR | 5V SUPPLY |
| 18 | K44 18TN/YL | CMP SIGNAL |
| 19 | K39 18GY/RD | IDLE AIR CONTROL NO. 1 DRIVER |
| 20 | K59 18VT/BK | IDLE AIR CONTROL NO. 4 DRIVER |
| 21 | - | - |
| 22 | A14 14RD/WT | FUSED B(+) |
| 23 | K22 18OR/DB | THROTTLE POSITION SENSOR SIGNAL |
| 24 | K41 18BK/DG | OXYGEN SENSOR 1/1 SIGNAL |
| 25 | K141 18TN/WT | OXYGEN SENSOR 1/2 SIGNAL |
| 26 | K241 18LG/RD (4.0L EXCEPT EXPORT/4.0L JAPAN LOW EMISSION VEHICLE) | OXYGEN SENSOR 2/1 SIGNAL |
| 27 | K1 18DG/RD | MAP SIGNAL |
| 28 | - | - |
| 29 | K341 18TN/WT (4.0L EXCEPT EXPORT/4.0L JAPAN LOW EMISSION VEHICLE) | OXYGEN SENSOR 2/2 SIGNAL |
| 30 | - | - |
| 31 | Z12 14BK/TN | GROUND |
| 32 | Z12 14BK/TN | GROUND |

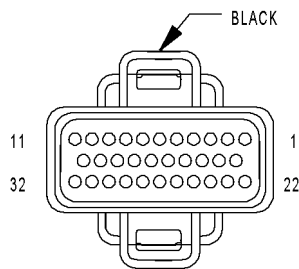

POWERTRAIN
CONTROL
MODULE C1

POWERTRAIN CONTROL MODULE C2 - WHITE 32 WAY

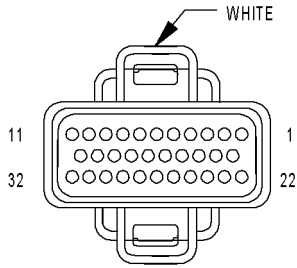

POWERTRAIN
CONTROL
MODULE C2

| CAV | CIRCUIT | FUNCTION |
|-----|--------------------|-----------------------------|
| 1 | - | - |
| 2 | - | - |
| 3 | - | - |
| 4 | K11 18WT/DB | FUEL INJECTOR NO. 1 DRIVER |
| 5 | K13 18YL/WT | FUEL INJECTOR NO. 3 DRIVER |
| 6 | K38 18GY (4.0L) | FUEL INJECTOR NO. 5 DRIVER |
| 7 | - | - |
| 8 | - | - |
| 9 | K17 18DB/TN | IGNITION COIL NO. 2 DRIVER |
| 10 | K20 18DG | GENERATOR FIELD |
| 11 | - | - |
| 12 | K58 18BR/DB (4.0L) | FUEL INJECTOR NO. 6 DRIVER |
| 13 | - | - |
| 14 | - | - |
| 15 | K12 18TN | FUEL INJECTOR NO. 2 DRIVER |
| 16 | K14 18LB/BR | FUEL INJECTOR NO. 4 DRIVER |
| 17 | - | - |
| 18 | - | - |
| 19 | C18 18DB (2.4L) | A/C PRESSURE SIGNAL |
| 20 | - | - |
| 21 | - | - |
| 22 | - | - |
| 23 | G60 18GY/YL | ENGINE OIL PRESSURE SIGNAL |
| 24 | - | - |
| 25 | - | - |
| 26 | - | - |
| 27 | G7 18WT/OR | VEHICLE SPEED SENSOR SIGNAL |
| 28 | - | - |
| 29 | - | - |
| 30 | - | - |
| 31 | K6 18VT/WT | 5V SUPPLY |
| 32 | - | - |

CONNECTOR PINOUTS

POWERTRAIN CONTROL MODULE C3 - GRAY 32 WAY

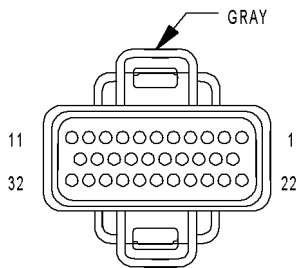

POWERTRAIN
CONTROL
MODULE C3

| CAV | CIRCUIT | FUNCTION |
|-----|-----------------------------|---|
| 1 | C13 18DB/OR (A/C) | A/C COMPRESSOR CLUTCH RELAY CONTROL |
| 2 | C24 18DB/PK (2.4L) | LOW SPEED RADIATOR FAN RELAY CONTROL |
| 3 | K51 18DB/YL | AUTOMATIC SHUT DOWN RELAY CONTROL |
| 4 | V36 18TN/RD (SPEED CONTROL) | SPEED CONTROL VACUUM SOLENOID CONTROL |
| 5 | V35 18LG/RD (SPEED CONTROL) | SPEED CONTROL VENT SOLENOID CONTROL |
| 6 | - | - |
| 7 | - | - |
| 8 | K99 18BR/OR | OXYGEN SENSOR 1/1 HEATER CONTROL |
| 9 | K512 18RD/YL (4.0L) | OXYGEN SENSOR DOWNSTREAM HEATER RELAY CONTROL |
| 10 | K106 18WT/DG | LEAK DETECTION PUMP SOLENOID CONTROL |
| 11 | V32 18YL/RD (SPEED CONTROL) | SPEED CONTROL ON/OFF SWITCH SENSE |
| 12 | A142 14DG/PK | AUTOMATIC SHUT DOWN RELAY OUTPUT |
| 13 | T10 18YL/DG (A/T) | TORQUE MANAGEMENT REQUEST SENSE |
| 14 | K107 18OR | LEAK DETECTION PUMP SWITCH SENSE |
| 15 | K118 18PK/YL | BATTERY TEMPERATURE SENSOR SIGNAL |
| 16 | K299 18BR/WT | OXYGEN SENSOR HEATER CONTROL |
| 17 | - | - |
| 18 | - | - |
| 19 | K31 18BR | FUEL PUMP RELAY CONTROL |
| 20 | K52 18PK/BK | EVAP/PURGE SOLENOID CONTROL |
| 21 | C27 18DB (2.4L) | HIGH SPEED RADIATOR FAN RELAY CONTROL |
| 22 | C21 18DB/OR (A/C) | A/C SWITCH SENSE |
| 23 | C90 18LG (A/C) | A/C SELECT INPUT |
| 24 | K29 18WT/PK | BRAKE LAMP SWITCH SENSE |
| 25 | K125 18WT/DB | GENERATOR SOURCE |
| 26 | K226 18DB/LG (4.0L) | FUEL LEVEL SENSOR SIGNAL |
| 27 | D21 18PK | SCI TRANSMIT |
| 28 | - | - |
| 29 | D32 18LG/WT | SCI RECEIVE |
| 30 | D25 18VT/YL | PCI BUS |
| 31 | - | - |
| 32 | V37 18RD/LB (SPEED CONTROL) | SPEED CONTROL SWITCH SIGNAL |

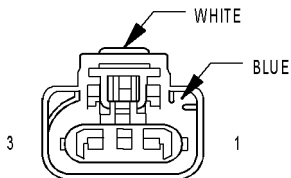

THROTTLE
POSITION
SENSOR
(2.4L)

THROTTLE POSITION SENSOR (2.4L) - WHITE/BLUE 3 WAY

| CAV | CIRCUIT | FUNCTION |
|-----|-------------|--------------------------------------|
| 1 | K7 18OR | 5 VOLT SUPPLY |
| 2 | K4 18BK/LB | SENSOR GROUND 1 |
| 3 | K22 18OR/DB | THROTTLE POSITION SENSOR NO.1 SIGNAL |

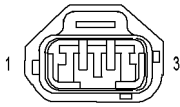

THROTTLE POSITION SENSOR (4.0L)

THROTTLE POSITION SENSOR (4.0L) - 3 WAY

| CAV | CIRCUIT | FUNCTION |
|-----|-------------|--------------------------------------|
| 1 | K7 200R | 5-VOLT SUPPLY |
| 2 | K4 20BK/LB | SENSOR GROUND 1 |
| 3 | K22 180R/DB | THROTTLE POSITION SENSOR NO.1 SIGNAL |

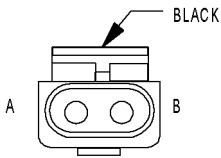

TRANSFER CASE SWITCH (EXCEPT OFF-ROAD PACKAGE)

TRANSFER CASE SWITCH (EXCEPT OFF-ROAD PACKAGE) - BLACK 2 WAY

| CAV | CIRCUIT | FUNCTION |
|-----|--------------|---------------|
| A | G107 20BK/RD | 4WD INDICATOR |
| B | Z1 18BK | GROUND |

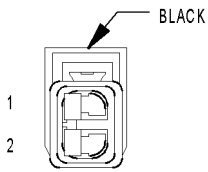

TRANSFER CASE SWITCH (OFF-ROAD PACKAGE)

TRANSFER CASE SWITCH (OFF-ROAD PACKAGE) - BLACK 2 WAY

| CAV | CIRCUIT | FUNCTION |
|-----|-------------|-------------------------------------|
| 1 | K77 18BR/WT | TRANSFER CASE POSITION SENSOR INPUT |
| 2 | K4 18BK/LB | SENSOR GROUND 1 |

CONNECTOR PINOUTS

CONNECTOR PINOUTS

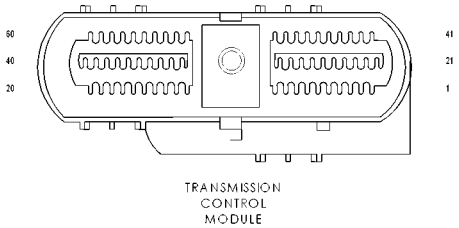

TRANSMISSION CONTROL MODULE - 60 WAY

| CAV | CIRCUIT | FUNCTION |
|-----|--------------|--|
| 1 | T1 18LG/BK | TRS T1 SENSE |
| 2 | - | - |
| 3 | T3 18VT | TRS T3 SENSE |
| 4 | - | - |
| 5 | - | - |
| 6 | K24 18GY/BK | CRANKSHAFT POSITION SENSOR SIGNAL |
| 7 | D21 18PK | SCI TRANSMIT |
| 8 | T141 18YL/RD | FUSED IGNITION SWITCH OUTPUT (START) |
| 9 | T9 18OR/BK | OVERDRIVE PRESSURE SWITCH SENSE |
| 10 | T10 18YL/DG | TORQUE MANAGEMENT REQUEST SENSE |
| 11 | F15 18DB/WT | FUSED IGNITION SWITCH OUTPUT (RUN-START) |
| 12 | K22 18OR/DB | THROTTLE POSITION SENSOR SIGNAL |
| 13 | T13 18DB/BK | SPEED SENSOR GROUND |
| 14 | T14 18LG/WT | OUTPUT SPEED SENSOR SIGNAL |
| 15 | K30 18PK | TRANSMISSION CONTROL RELAY CONTROL |
| 16 | T16 16RD | TRANSMISSION CONTROL RELAY OUTPUT |
| 17 | T16 16RD | TRANSMISSION CONTROL RELAY OUTPUT |
| 18 | T56 18DG/LB | OVERDRIVE OFF SWITCH INDICATOR |
| 19 | T19 16WT | 2-4 SOLENOID CONTROL |
| 20 | T20 16LB | LOW/REVERSE SOLENOID CONTROL |
| 21 | - | - |
| 22 | - | - |
| 23 | - | - |
| 24 | - | - |
| 25 | - | - |
| 26 | - | - |
| 27 | - | - |
| 28 | - | - |
| 29 | - | - |
| 30 | - | - |
| 31 | - | - |
| 32 | - | - |
| 33 | - | - |
| 34 | - | - |
| 35 | - | - |
| 36 | - | - |
| 37 | - | - |
| 38 | - | - |
| 39 | - | - |
| 40 | - | - |
| 41 | T411 18WT/PK | TRS T41 SENSE |
| 42 | T42 16VT/WT | TRS T42 SENSE |
| 43 | D25 18VT/YL | PCI BUS |
| 44 | - | - |
| 45 | - | - |
| 46 | D20 18LG | SCI RECEIVE |
| 47 | T47 18YL/BK | 2-4 PRESSURE SWITCH SENSE |
| 48 | - | - |
| 49 | T6 18OR/WT | OVERDRIVE OFF SWITCH SENSE |
| 50 | T50 18DG | LOW/REVERSE PRESSURE SWITCH SENSE |
| 51 | K4 18BK/LB | SENSOR GROUND 1 |
| 52 | T52 18RD/BK | INPUT SPEED SENSOR SIGNAL |
| 53 | Z112 16BK | GROUND |
| 54 | T54 18VT | TRANSMISSION TEMPERATURE SENSOR SIGNAL |
| 55 | - | - |
| 56 | A30 16RD/WT | FUSED B(+) |
| 57 | Z113 16BK/YL | GROUND |
| 58 | - | - |
| 59 | T59 16PK | UNDERDRIVE SOLENOID CONTROL |
| 60 | T60 16BR | OVERDRIVE SOLENOID CONTROL |

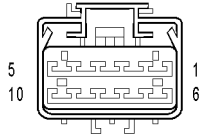

TRANSMISSION RANGE SENSOR

TRANSMISSION RANGE SENSOR - 10 WAY

| CAV | CIRCUIT | FUNCTION |
|-----|--------------|--|
| 1 | F20 20VT/WT | FUSED IGNITION SWITCH OUTPUT (RUN) |
| 2 | - | - |
| 3 | T13 18DB/BK | SPEED SENSOR GROUND |
| 4 | T54 18VT | TRANSMISSION TEMPERATURE SENSOR SIGNAL |
| 5 | T41 20BK/WT | PARK/NEUTRAL POSITION SWITCH SENSE (T41) |
| 6 | L1 20VT/BK | BACK-UP LAMP FEED |
| 7 | T1 18LG/BK | TRS T1 SENSE |
| 8 | T3 18VT | TRS T3 SENSE |
| 9 | T42 16VT/WT | TRS T42 SENSE |
| 10 | T411 18WT/PK | TRS T41 SENSE |

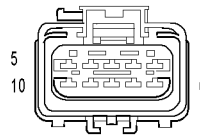

TRANSMISSION SOLENOID/PRESSURE SWITCH ASSEMBLY

TRANSMISSION SOLENOID/PRESSURE SWITCH ASSEMBLY - 10 WAY

| CAV | CIRCUIT | FUNCTION |
|-----|-------------|-----------------------------------|
| 1 | T60 16BR | OVERDRIVE SOLENOID CONTROL |
| 2 | T59 16PK | UNDERDRIVE SOLENOID CONTROL |
| 3 | T16 16RD | TRANSMISSION CONTROL RELAY OUTPUT |
| 4 | T19 16WT | 2-4 SOLENOID CONTROL |
| 5 | T47 18YL/BK | 2-4 PRESSURE SWITCH SENSE |
| 6 | T9 18OR/BK | OVERDRIVE PRESSURE SWITCH SENSE |
| 7 | T20 16LB | LOW/REVERSE SOLENOID CONTROL |
| 8 | - | - |
| 9 | - | - |
| 10 | T50 18DG | LOW/REVERSE PRESSURE SWITCH SENSE |

10.0 SCHEMATIC DIAGRAMS

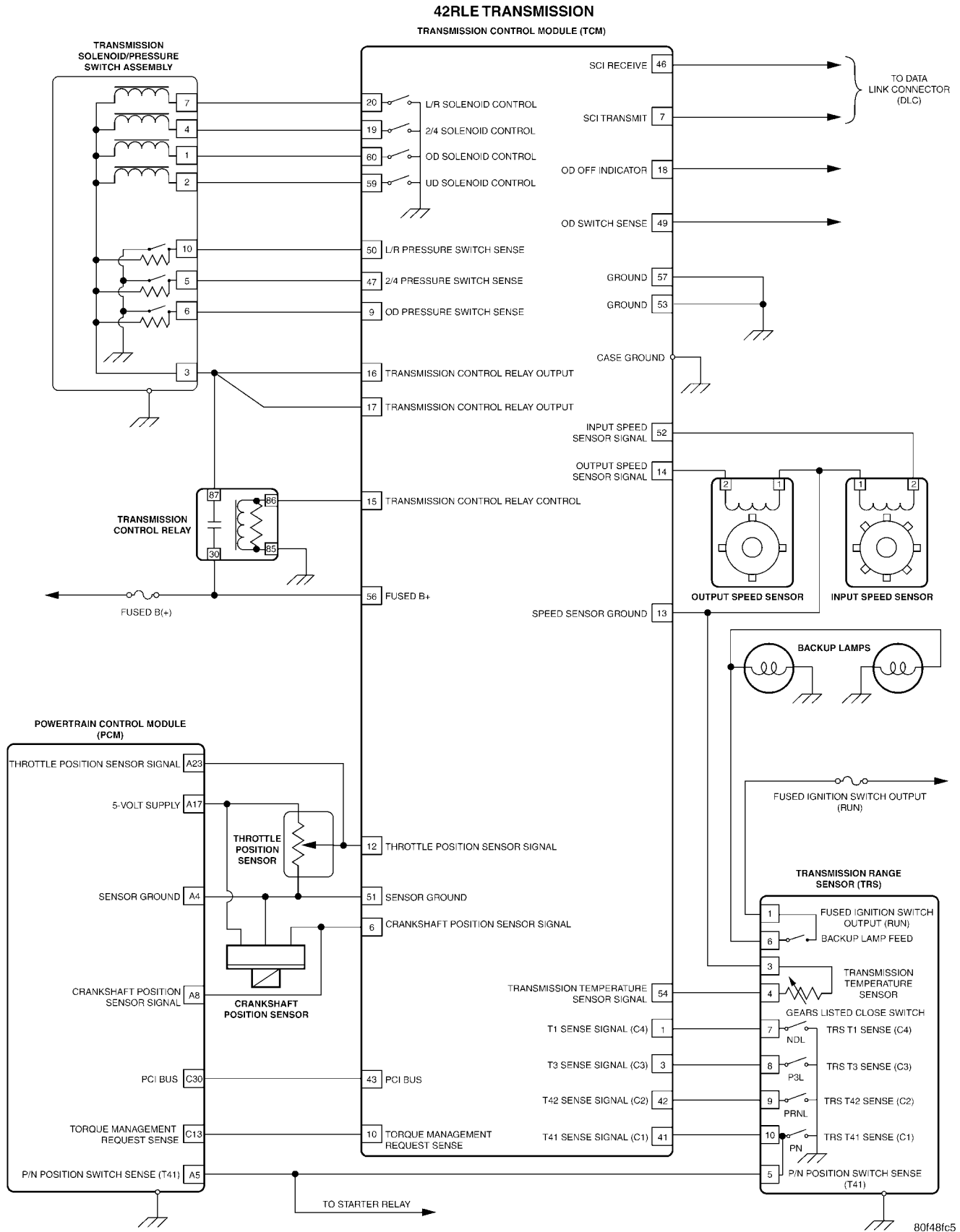

SCHEMATIC DIAGRAMS

11.0 CHARTS AND GRAPHS

11.1 PRESSURE SWITCH STATES

PRESSURE SWITCH STATES

| SWITCHES | R | N | 1ST | 2ND | 3RD | 4TH |
|----------|------|--------|--------|--------|--------|--------|
| L/R | OPEN | CLOSED | CLOSED | OPEN | OPEN | OPEN |
| 2/4 | OPEN | OPEN | OPEN | CLOSED | OPEN | CLOSED |
| O/D | OPEN | OPEN | OPEN | OPEN | CLOSED | CLOSED |

80d9d3b5

11.2 SOLENOID APPLICATION CHART

SOLENOID APPLICATION CHART

| GEAR | UD | OD | REV | 2/4 | LR |
|---------|----|----|-----|-----|----|
| PARK | | | | | X |
| REVERSE | | | X | | X |
| NEUTRAL | | | | | X |
| 1ST | X | | | | X |
| 2ND | X | | | X | |
| 3RD | X | X | | | |
| 4TH | | X | | X | |

80ccf4c0

11.3 SHIFT LEVER ERROR CODES

**SHIFT LEVER ERROR CODES
REPORTED BY THE DRBIII®**

| ERROR CODE | SWITCH STUCK | POSITION |
|------------|--------------|----------|
| 1 | T1/C4 STUCK | OPEN |
| 2 | T1/C4 STUCK | CLOSED |
| 3 | T3/C3 STUCK | OPEN |
| 4 | T3/C3 STUCK | CLOSED |
| 5 | T42/C2 STUCK | OPEN |
| 6 | T24/C2 STUCK | CLOSED |
| 7 | T41/C1 STUCK | OPEN |
| 8 | T41/C1 STUCK | CLOSED |

80ccf2de

CHARTS AND GRAPHS

11.4 TRANSMISSION TEMPERATURE SENSOR

TRANSMISSION TEMPERATURE SENSOR (DUAL RANGE)

START ENGINE. WITH DRB, MONITOR AND RECORD TRANSMISSION TEMPERATURE VOLTAGE. COMPARE THE MEASURED TEMPERATURE AND VOLTAGE WITH THE GRAPH SHOWN BELOW. THE MEASURED VALUE SHOULD FALL ON ONE OF THE LINES ON THE GRAPH.

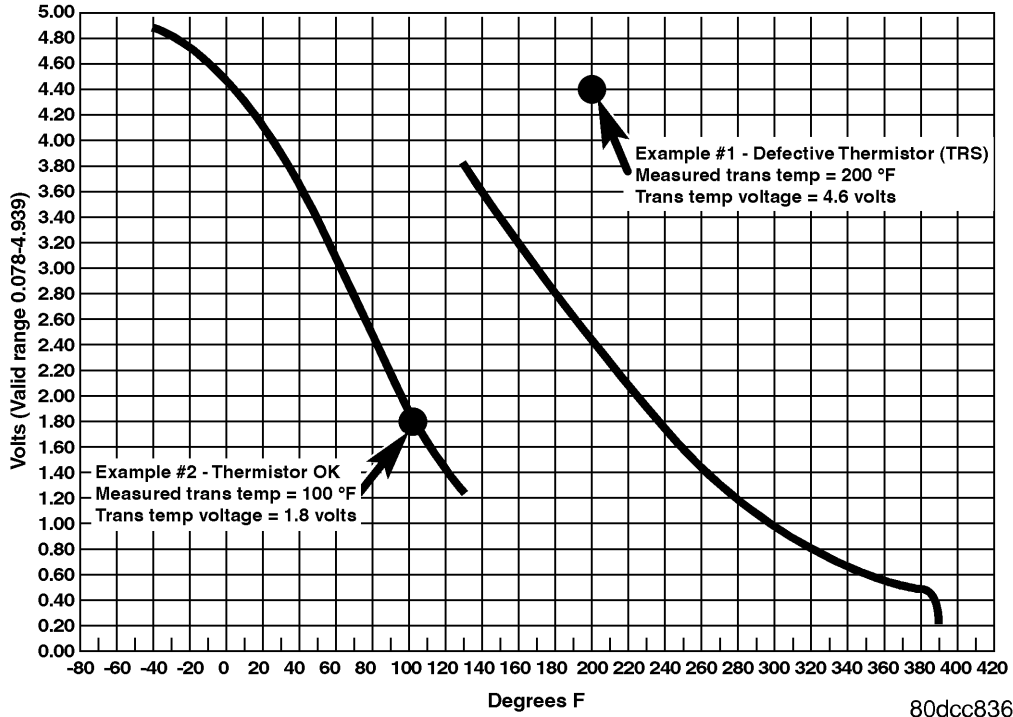

80dcc836